

SPXFLOW

› Power Team®





ABOUT POWER TEAM

Tough Products for Tough Applications

Hydraulic Pumps

- Electric and Air Powered
- Electric, Air, and Gas Powered
- Hand Pumps
- Valves, Hoses and Accessories

Hydraulic Cylinders

- Rams
- Standard
- Construction
- Industrial
- High Tonnage
- Pancake
- Aluminum
- Pulling

Jacks

- Lifting Jacks
- Inflatable Jacks
- Post-Tensioning Jacks

Tools

- Hydraulic Presses
- Flange Spreaders
- Nut Splitters
- Gear Pushers/Pullers
- Bearing Maintenance Pushers/Pullers

Shop Equipment

- Shop Presses
- Floor Cranes
- Spread Tilters

Power Team. 90 years experience in supplying Professional Grade high-pressure Hydraulic Pumps, Cylinders, Jacks, Pullers & Tools.

A Heritage of Innovation

Since 1924, we've been instrumental in the development of innovative high force hydraulic power products, systems and tools. And many of our products are known as the industry standard for rugged construction, reliability, and long service life. Today, we provide a full range of professional grade products and services around the globe.

Power Team Quality

Power Team Products are built tough with strict ISO 9001 manufacturing processes and are covered by a Lifetime Powerthon Warranty*.

Global Distribution and Service

Wherever your job is in the world, the Power Team network of distributors and service centers assures local product, parts and service availability.

*See Warranty page for coverage details.



NEW
PAGE 78

10 Ton Start-Up Kit



CYLINDERS
12-41



PUMPS
42-119



NEW

**HYDRAULIC
ACCESSORIES**
120-133



**SHOP
EQUIPMENT**
134-147



JACKS
148-163



**HYDRAULIC AND
MECHANICAL
TOOLS**
164-189



PULLERS
190-230

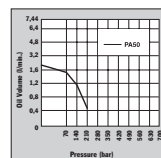

RESOURCES
231-236

BB1600.....178	PG120HM.....108	SPE15013DS -	216209.....116	350549, 350550.....175	9190.....128
BC212 - BC212EUR...81	PG303 - PG554...106-107	SPE20013DS.....141	21669 - 21873.....45	350593-350594.....226	9500, 9501.....53
BP12INT.....81	PG1200M-4 -	SPH1010.....137	22041-22044.....186	350637.....226	9502.....52
C51C - C10010C.....17	PG1204S.....108-109	SPM1010.....137	22185.....206	350722.....61	9504.....51
C55CBT -	PG4004.....108-109	SPM256.....138	22274, 22275.....45	350723-350724.....36	9506, 9507.....53
C2514CBT.....18	PG4004S.....108-109	SPM256C.....136	24016.....41	350822, 350823.....175	9508, 9509.....131
CB30 - CB100.....40	PH53C.....216	SPM2514.....138	24196, 24197.....4524813,	350895-350898.....37	9510.....117
CBS55 - CBS150.....162	PH53CR.....216	SPM556.....139	24814.....42	350984.....38	9511.....53
CC5 - CC25.....177	PH63C - PH113C.....214	SPM5513.....139	24835, 24836.....204	351075.....25	9512, 9513.....56
DG100, DG100B.....125	PH103C, PH103CR.....216	SPM10010.....140	25017.....116	351106.....25	9514.....131
FC2200 - FC4400.....146	PH172 - PH503.....217	SS2.....206	250175.....118	351324, 351325.....38	9515.....117
FLS15.....180-181	PH553C -	TBP1622.....144	250341-250343.....159	351334.....38	9516.....56
FK59 - FK159B.....60	PH553CL13.....226	TPP1-TPP200.....144	250353.....159	351574 - 351576.....37	9517.....51
HFS3A - HFS6A.....175	PH1002 - PH1002J.....227	TPS6.....144	250459.....182	351927 - 351931.....161	9519.....56
HB443, HB444.....110	PLA6014.....161	TWHC.....168	250682.....159	351953, 351954.....161	9520.....52
HNS150 - HNS225.....174	PLE6014K.....161	TWLC.....169	251002.....226	351985.....174	9521.....117
HP20 - HP35SP.....182-183	PMA, PUA.....76-77		251468.....226	36161.....233	9522, 9523.....56
HS2000 - HS3000.....176	PPH17 -	0100 - 0600.....187	251646, 251647.....213	36469.....145	9524.....130
HST11.....215	PPH50R.....218, 219	1020 - 1050.....196-197	251660.....116	36578.....209	9525, 9526.....131
HST11S.....214	PTPHB-206 -	1057 - 1060.....216	251970-251999.....183	37045.....185	9531.....117
HT50A - HT200.....184	PTPHD-216.....196	1062.....218	252000.....183	37368.....145	9552.....55
HTS50.....188	PTPH-102T -	1064, 1066.....217	252001-252002.....183	38597.....177	9553.....56
IM10E, IM10H.....156	PTPH-200T.....197	1070.....219	252215.....41	38855, 38904.....41	9554.....130
IJ13T - IJ7520T.....158	PQ603 -	1074.....217	252511, 252512.....118	38908, 38909.....37	9555, 9556, 9559.....131
IPS10B.....209	PQ1204S.....98-103	1076.....219	252542 - 253391.....157	38953.....177	9560.....81
IPS10HB.....209	PR102 - PR104.....80-81	1080.....217	25388 - 25750.....40-41	38954.....144	9561-9563.....80
IPS10M.....212	PR2100J Thru.....230-231	10461.....116	25931.....42	39811.....188	9569, 9570, 9572.....55
IPS17M.....220	PR3100S.....230-231	10494.....118	26068 - 26666.....186	41331.....204	9575.....133
IPS17 - IPS17H.....220	PT202-PT116.....197	1100 - 1111.....203	27198.....42	420059 - 420064.....36	9576.....52
IPS30H.....221	PTPH-206 -	1120.....187	27241.....206	420496BK2.....41	9579.....55
IPS3017-IPS3017B.....222	PTPHA-116.....197	1121 - 1124.....205	27287.....186	420496OR9.....41	9580, 9581.....133
IPS5017 - IPS5017B.....223	R552C - R56510C.....28	1125.....187	27315.....206	420498OR9.....41	9582, 9584.....51
IPS5317.....224	PTPHB-206 -	1128.....219	27487-27555.....230	420655OR9.....41	9589, 9590.....56
J24T - J259T.....152-153	PTPHD-216.....198	1121-1130.....205	27737.....186	420866-420871.....38	9592.....55
JAM10033 -	PTPH-102T -	1131.....187	27793 - 27797.....230	421056, 421057.....25	9593.....130
JEM15026.....163	PTPH-200T.....199	1150 - 1154.....204	27876, 27877.....115	421312OR9.....41	9594.....55
K82, K83.....211	R1002D - R56510D.....30	1155 - 1158.....206-207	28228-28229.....177	43562, 43563.....144	9595.....130
LR2000 - LR6000.....147	R552L - R56510L.....31	1165, 1166.....204	28230.....38	44148, 44195.....206, 208	9596, 9597.....132
MB5 - MB16.....213	RA202 - RA1006.....17	1170, 1171.....207	28250 - 28256.....206	44457, 44458.....145	9599, 9605.....54
MCS.....166	RA556L, RA1006L.....32	1172 - 1178.....206-207	28323GY8.....206	44745, 44766.....223	9608.....54
MIT-B.....178	RB8013S -	1180 - 1182.....208	28612 - 28644.....41	45329.....188	9609.....132
P12 - P59F.....58-59	RB20013S.....133	1188.....215	28984, 28985.....186	45589.....40	9610, 9610A.....51
P19, P59.....59	RC5.....119	1266.....189	29595.....38	46070.....144	9615.....56
P157 - P460D.....60	RC12V.....81	1320 - 1349.....187	302482, 302483.....38	518, 522.....210	9616.....126
PA6 - PA6DM-2.....62-65	RD106 - RD50013.....27	13449.....186	303045.....223	58943 - 58945.....162	9617.....127
PA7.....206	RH102 -	15235.....159	303785.....38	60846.....136	9620.....117
PA9, PA9H.....66-67	RH2008.....23	15702.....187	304718.....116	66053 - 66055.....161	9623.....133
PA50 - PA50RM.....70-71	RH306D.....23	16339.....118	307159.....159	679, 680.....204	9625.....117
PA60, PA64.....68-69	RHA306.....22	16954.....186	307281.....185	7053K.....187	9626, 9627.....127
PA60APF5FP -	RHA604D.....23	17627.....116	308022.....174	7103.....188	9628.....57
PA60APF5FPR.....170	RH121T.....22	1890-1893.....145	308435OR9 Thru.....221-224	7123K, 7125K.....187	9631.....133
PA172 - PA554.....72-75	RLS50 - RLS1500S.....20	201362 - 201412.....233	308440OR9.....174	7136.....207	9632.....57
PB1230C -	RP20 - RP104.....119	201454, 201923.....177	308840.....174	714.....187	9633.....133
PB51156C.....213	RP25, RP55.....25	202178 - 202180.....36	309652, 309653.....116	7162-7168.....189	9634, 9635.....127
PC200, PC200RC.....119	RPS55 - RPS556A.....61	202777, 202778.....116	31772, 31776.....36-37	7180.....230	9636-9640.....126
PD313 - PD812.....183	RSS101 - RSS2503.....21	202817.....188	32054.....202	7300, 7301.....187	9641.....117
PE-NUT.....104, 180	RT172 - RT1004.....24	203003 - 203156.....186	32118.....38	7307-7309.....189	9642.....127
PE102 -	RV21278 -	203225.....116	32325.....36-37	7312.....188	9643.....117
PE104.....80-81	RV21278-90.....133	203264.....185	32698 - 33439.....38	7313.....187	9644.....127
PE120M.....112	RWP55.....173	204666.....188	3344.....188	7392, 7393.....210	9645-9647.....126
PE172 - PE174M.....82-83	SF50.....139, 142	204928.....189	33856-33865.....206	7395.....188	9648.....127
PE18.....84-85	SF150.....140-142	204990.....185	34136.....38	7400, 7401.....189	9670-9690.....128
PE182 -	SJ2010 - SJ3010P.....157	206753.....186	34251.....41	7402.....127	9691.....127
PE184C.....84-85	SK10TE.....78	206767.....118	34331.....206	7406K.....187	9692 - 9705.....128
PE213 - PE214S.....86-87	SK25TE.....79	207395.....144	34510, 34511.....177	7420, 7421.....189	9720, 9721.....132
PE302 -	SP1010A.....137	207762.....118	34698.....206	8000 - 8076.....210-211	9733-9783.....122
PE304R-2.....90-91	SPA10 - SPA200.....145	208380-208382.....37	34755, 34756.....38	8110 - 8148.....210	9758, 9763.....157
PE30TWP.....171	SPA256, SPA2514.....138	208401, 208402.....186	34758.....38	885.....189	9785-9788.....185
PE55TWP.....172	SPA556.....139	208406.....41	34806 - 34807.....145	927 - 939.....203	9792 - 9800.....123
PE462 - PE464S.....92-93	SPE1010.....137	208627.....206	34808.....145	9002A -	981.....206
PE552 - PE554T.....94-95	SPE1010D.....137	209199, 209200.....189	350090.....159	9050A.....150-151	
PE604T -	SPE256 -	209201.....187	350094-350100.....36	9040 - 9091.....125	
PE604PT.....96-97	SPE2514DS.....138	209593.....116	350144, 350145.....37	9006X - 9015X.....154	
PE4004.....102-103	SPE556 -	212377.....230	350184.....36	9105A.....155	
PED253 -	SPE5513DS.....139	12867.....209	350207-350209.....159	9112A -	
PED254S.....88-89	SPE10010 -	21332.....145	350320-350334.....38	9130A.....150-151	
	SPE10013DS.....140	213895, 213896.....119	350376.....37	9015B - 9110B.....150	
	SPE10010R.....140	215315.....209	350431.....115	9205A - 9220A.....155	

A	
Adapters, Step Plate.....211	
Adapters, Threaded	
(Puller).....210-211	
Air/Hydraulic Pumps.....62-77	
Aluminum Cylinders.....17, 22, 23,	
30, 32	
Assemble to Order”	
Pumps.....112-115	
Attachments, Pulling.....201-202	
Axle Journal Roller Bearing	
Service Equipment.....230	
B	
Bead Breaker.....178	
Bearing Cup Installer.....230	
Bearing Cup Remover.....207	
Bearing Pulling	
Attachments.....204-205	
Bench Presses.....137	
Blankets, Protective.....213	
Blind Hole Puller Set.....206	
Bundles Posi-Lock.....198	
Bushing and Bearing Drivers.....230	
C	
Cable Tools.....178	
Casters.....118, 217	
Center-Hole	
Cylinders.....22, 23	
Accessories.....41	
Center-Hole Twin Cylinders.....24	
C-Clamps.....177	
C-Frame Press.....136	
Chain Wrenches.....189	
Chaser, Thread.....188	
Compression Tools.....178-181	
Counter-balance Valve.....132	
Couplers, Hydraulic.....123, 128	
Crane Accessories.....147	
Cranes, Mobile.....146	
Cribbing Block Sets.....40, 160-162	
Cylinder-Pump-Hose Sets,	
Hydraulic.....61	
Cylinders, Hydraulic.....12-41	
D	
Digital Pressure Gauge.....124-125	
Double-Acting Cylinders	
.....18, 19, 23, 24, 26, 27	
E	
Electric/Air Pump	
Torque Wrench Pump.....170	
Electric/Hydraulic	
Pumps.....80-103	
“Enforcer 55”	
Hydraulic Puller.....226	
“Enforcer 100”	
Hydraulic Puller.....227	
F	
Filter/Regulator/Lubricator, Air117	
Fixtures, Straightening.....139-142	
Flange Spreaders.....175	
Floor Cranes, Mobile.....136	
Flow Characteristics, Valves	
.....48-50, 129	
Fluid Level &	
Temperature Gauge.....118	
Foot Pump Conversion Kit.....60	
Forcing Presses.....126-135	
G	
Gauges, Hydraulic	
Pressure.....124-125	

Gear and Pulley.....126	
Pullers.....200-226, 226-229	
Gland Nut Wrench, Adjustable 189	
H	
Head Inserts, Cylinder.....41	
High Pressure	
Air Operated Pump.....76-77	
Horseshoe Lock Ring Plier.....187	
Hose, Hydraulic.....122	
Hydra Grip-O-Matic Pullers.....214	
Hydraulic Accessories.....120-133	
Hydraulic Couplers.....123, 128	
Hydraulic Cranes.....146	
Hydraulic Cylinders.....12-41	
Hydraulic Fittings.....128	
Hydraulic Gauges.....124-125	
Hydraulic Hose.....122	
Hydraulic Intensifier.....185	
Hydraulic Jacks.....148-163	
Hydraulic Oil.....126	
Hydraulic Presses, Shop.....134-143	
Hyd. Puller Sets.....220	
Hydraulic Pumps.....42-119	
Hydraulic Pump-	
Cylinder-Hose Sets.....61	
Hydraulic Pullers Posi-Lock.....199	
Hydraulic Punches.....182-183	
Hydraulic Spreaders.....176-181	
Hydraulic System Testers.....184	
Hydraulic Tester Accessories.....185	
Hydraulic Tools.....164-189	
Hydraulic Valves.....42-57	
In-Line.....132-133	
Remote.....129-131	
I	
Industrial Maintenance Sets.....156	
Puller Sets.....212-213, 220-222	
In-Line Valves.....132-133	
Inflatable Jacks.....158-159	
Intensifier, Hydraulic.....110, 111, 185	
Internal Pulling	
Attachments.....200	
J	
Jack Modules.....162-163	
Jack Screw Attachments.....160	
Jacks, High-Tonnage.....160-163	
Jacks, Hydraulic.....148-163	
Jacks, Hydraulic Toe.....152-153	
Jacks, Inflatable.....158-159	
Jacks, Stressing.....157	
Jimmy Bars.....189	
L	
Lightweight Handpump.....59	
Load-Lowering Valve.....132	
Load-Positioning Slings.....147	
Low Profile Cylinders.....20	
M	
Magnetic Pick-Up Tool.....188	
Magnetic Strip.....118	
Maintenance Sets.....156	
Manifolds.....127	
Metering Valve.....133	
Metric Conversion Charts.....234	
Mini Jack.....155	
Motion Control System.....166	
N	
Nut Splitters.....174	
O	

Oil, Hydraulic.....126

Selection Chart

Choose the right pump: This chart helps you calculating the time required for a cylinder to lift a load when powered by a 700 bar Power Team pump. For the hand pumps the number indicates the number of strokes to extend 25 mm. For the electric/air/gas pumps the number indicates the number of seconds to extend 25 mm.

		Cylinder Capacity (Tons)														
		STAGE	5	10	15	20	25	30	55	75	100	150	200	300	400	500
Hand Pumps *	P12	Single	14	32	44	65	72	93								
	P55	Single	6	14	19	28	31	40	71							
	P19/	Low	4	8	10	15	17	21								
	P19L	High	13	30	42	59	68	86								
	P59F	Low	1,8	4,1	5,7	8	9	12	20	29						
		High	8	17	24	34	48	50	85	122						
	P59(L)	Low	1,5	3,2	4,7	7	7,7	9,7	16,7	23,9						
	P157	High	6	14	19	28	31	40	71	101						
	P159	Low	0,5	1	1,3	1,9	2,2	2,8	5	7	9	13	18			
	P300	High	7	15	21	30	34	43	77	110	143	200	250			
		P460	Low	0,1	0,3	0,6	0,6	0,7	0,9	1,5	2,2	2,8	4,2	5,6	8,4	11,2
	High		3,3	7,7	9	14	17,5	22	37	55	71	105	143	213	284	
Electric Hydraulic Pumps **	PE10	Low	0,5	1,2	1,6	2,2	2,6	3,2	5,5							
		High	6	13,4	18,9	27	31	39	66,2							
	PE17	Low	0,2	0,5	0,7	0,9	1,1	1,4	2,3	3,3	4,3	6,5	8,7			
		High	3,5	7,9	10,9	16	18	23	39	56,3	73	109	146			
	PE18	Low	0,4	0,8	1,2	1,6	1,8	2,3	3,9	5,7	7,3	10,8	14,6	21,9	29,2	
		High	3,3	7,5	10,3	15	17	21	37	53	69	102	136	207	276	
	PE21	Low	0,2	0,5	0,7	1	1,1	1,4	2,5	3,6	4,6	6,8	9,2	13,8	18,4	
		High	2,8	6,4	9	13	15	19	32	45,5	59	88	118	177	236	
	PED25	Low	0,2	0,4	0,6	0,9	1	1,3	2,2	3,2	4,1	6,1	8,3	12	15,7	19,9
		High	2,4	5,4	7,5	10,6	12,4	15,6	26,5	38,2	49,5	73,6	99,1	144,3	188,5	238,6
	PE30	Low	0,2	0,45	0,6	0,9	1	1,3	2,2	3,2	4,1	6				
		High	2	4,5	6	9	10	13	22	32	41	60				
	PE46	Low	0,1	0,3	0,4	0,5	0,6	0,7	1,3	1,8	2,4	3,5	4,7	7,2	9,6	
		High	1,3	2,9	4,1	5,9	6,8	8,6	14	22	28	42	56	84	112	
	PE55/	Low	0,1	0,2	0,3	0,4	0,4	0,6	0,9	1,4	1,8	2,6	3,5	5,4	7,2	
	PE60	High	1,1	2,4	3,4	4,8	5,6	7,1	12	17,8	23	34	45	69	92	
	PQ60	Low	0,1	0,2	0,3	0,4	0,4	0,5	0,9	1,3	1,7	2,5	3,4	5,1	6,8	8,5
		High	1	2,2	3,3	4,4	5,2	6,5	11	16,2	21	31	41	63	84	105
PQ120	Low	0,1	0,2	0,3	0,4	0,4	0,5	0,9	1,3	1,7	2,5	3,4	5,1	6,8	8,5	
	High	0,5	1,1	1,6	2,2	2,6	3,2	5,5	7,7	10	15	21	30	40	50	
PE400	Low	0,1	0,1	0,2	0,2	0,3	0,3	0,6	0,8	1	1,5	2,1	3	4	5	
	High	0,1	0,3	0,4	0,6	0,7	0,9	1,6	2,2	2,9	4,4	5,9	8,7	11,6	14,5	
Air Hydraulic Pumps **	PA6/	Single	10	22,4	31	44,4	51,3	65,2	-	-	-	-	-	-	-	
	PA9	Single	10	22,4	31	44,4	51,3	65,2	-	-	-	-	-	-	-	
	PA17	Low	0,2	0,5	0,7	0,9	1,1	1,4	2,3	3,3	4,3	6,5	8,7	-	-	
		High	3,5	7,9	10,9	16	18	23	39	56	73	109	146			
	PA46	Low	0,1	0,3	0,4	0,5	0,6	0,7	1,3	2	2,4	3,5	4,7	7,2	9,6	
		High	1,3	2,9	4,1	5,9	6,8	8,6	14	22	28	42	56	84	112	
PA55	Low	0,1	0,3	0,4	0,6	0,7	0,9	1,5	2,2	2,8	4,1	5,5	8,4	11,2		
	High	1,1	2,4	3,4	4,8	5,6	7,1	12	18	23	34	45	69	92		
Gas Hydraulic Pumps **	PG30	Low	0,3	0,7	1	1,3	1,6	2	3,3	4,8	6,2	9,3	12,4	18,1	-	
		High	2	4,5	6,3	8,9	10,3	13	22	31,8	41,3	61,4	83	121	-	
	PG55	Low	0,1	0,3	0,4	0,6	0,7	0,8	1,4	2	2,6	3,9	5,2	7,6	9,9	12,5
		High	1,1	2,5	3,5	4,9	5,6	7,1	12,1	17,3	22,5	33,5	45	66	86	109
	PG120	Low	0,1	0,3	0,4	0,6	0,7	0,8	1,4	2	2,6	3,9	5,2	7,6	9,9	12,5
		High	0,5	1	1,5	2	2,4	3	5,1	7,3	9,5	14,2	19,1	27,8	36,3	46
PG400	Low	0,1	0,1	0,2	0,2	0,3	0,3	0,6	0,8	1	1,5	2	3	3,8	4,9	
	High	0,2	0,3	0,5	0,7	0,8	1	1,7	2,4	3,1	4,6	6,2	9	11,8	15	

 - Generally Recommended
 - Marginal Check
 - Not Recommended for most applications

Speed *number of strokes to extend 25 mm
 **number of seconds to extend 25 mm



Power Team®



OFFICIAL SPONSOR

STRONGMEN CHAMPIONS LEAGUE



Powerful Tools







Selection

Choosing The Right Cylinder

Step 1 Select the hydraulic cylinder that best suits the application. See page 6, 12-13.

Step 2 Select the hydraulic pump, with valve option, that best matches the cylinder and application. See pages 6, 44-50.

Step 3 Select the hydraulic accessories you need. See pages 36-41.

WHAT TYPE OF CYLINDER DO YOU NEED?

1. To determine a cylinder's force capacity:

Force pounds \times Cylinder Effective Area (cm²) = PSI from Pump

2. To determine oil capacity of a cylinder:

Oil Capacity (cu. in.) \times Cylinder Effective Area (cm²) = Cylinder Stroke (in.)

3. To determine reservoir capacity needed for a multiple cylinder system:

Usable Oil \times Oil Cap. of Cyl. (cm³) = Number of Cyl. in System

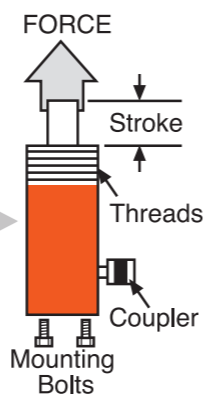

CONSIDERATIONS:

1. What push or pull tonnage is required per cylinder in your application? (Rule of thumb; Always choose a cylinder with a tonnage rating of 20% or more than what is required to lift the load.)
2. What is the push or pull stroke length required?
3. Does the cylinder need to push, pull or both? (Single-acting cylinders extend the piston under hydraulic pressure; double-acting cylinders extend and retract the piston under pressure.)
4. Does the application require multiple cylinders?
5. Is the application stationary, or must the components be light in weight for easy portability?
6. Do you need to extend a rod or cable through the center of the cylinder for the application, as in a tensioning operation?
7. Does the application require that the cylinder fit within limited-clearance work areas?
8. Does the application require that the cylinder be "dead-ended" at the end of its work stroke?
9. Will the cylinder need to withstand off-center loads? Cylinders with swivel caps are available.
10. Does the application require that the lifted load be supported for extended periods of time? Locking collars are ideal for such jobs, as are cribbing blocks.
11. Is corrosion resistance required? Our unique "Power Tech" surface treatment is standard on many Power Team cylinders, and optional on many of our cylinders which feature steel construction.
12. Will the application involve high cycles (over 2,500 in the cylinder's lifetime)? Our "RD," "RH," "RP" and "C" series cylinders are ideal choices. Please refer to pages 12-13 for the capabilities of each cylinder.



ONLY POWER TEAM PROVIDES THE POWER TECH SURFACE TREATMENT:

- High corrosion and wear resistance, anti-galling properties.
- Significantly increases the life expectancy of a cylinder.
- Retains lubricants, prevents bronze and other materials from sticking to surface.
- Increases fatigue and impact strength.
- Increases surface yield and tensile strength.
- Provides improved abrasion and scratch resistance.
- Causes no appreciable dimensional change.
- 56 RC minimum surface hardness.
- Passes ASTM B117-85 100 hour salt spray corrosion resistance tests.

The "Power Tech" surface treatment is standard on the gland nut, cylinder body and piston/piston rod of the following cylinders: RLS50, RLS100, RLS200, RLS300, RLS500S, RLS750S, RLS1000S, RLS1500S, and RSS1002. NOTE: Bronze plating may be used in place of the "Power Tech" surface finish for the piston/piston rod of any of the above cylinders. The "Power Tech" surface treatment is standard on the standpipe of all "RH" series single and double-acting cylinders. The "Power Tech" surface treatment is standard on the piston/piston rod of the RT172, RT302 and RT503 cylinders.

Hydraulic CIRCUITS

Pumps, Cylinders, Controls

These are just a few basic systems possible with Power Team hydraulic components. Countless applications are possible: In presses, for lifting or jacking applications or in production or maintenance setups. The pump shown is a typical electric/hydraulic unit. Electric, air or gas driven pumps are available.

1 Single-acting cylinder or cylinders in the circuit, controlled by a pump mounted valve.

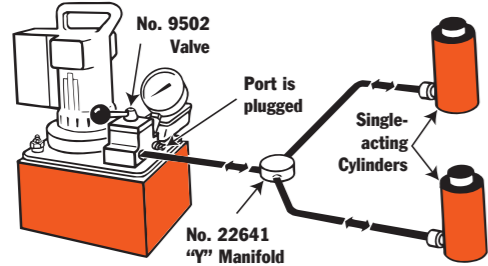

2 Double-acting cylinder or cylinders in the circuit, controlled by a pump mounted valve.

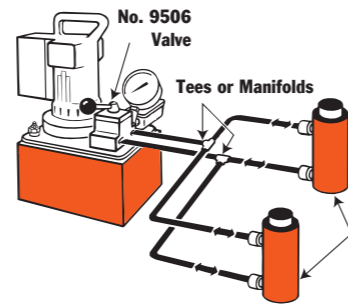

3 Single-acting cylinder controlled by a remote mounted valve.

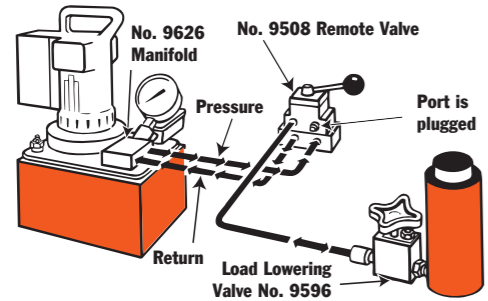

4 Double-acting cylinders controlled by a remote mounted valve.

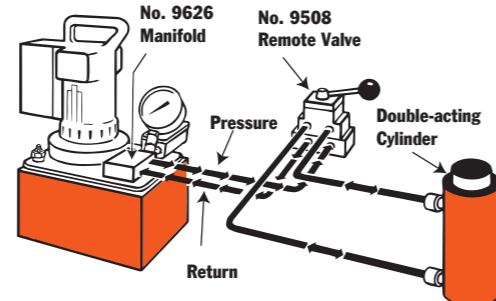

5 Single-acting cylinders with a sequence valve which controls the primary and secondary cylinder circuits.

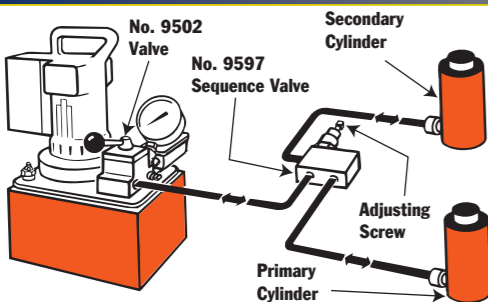

6 Double-acting cylinder with a sequence valve which controls the primary and secondary cylinder circuits.

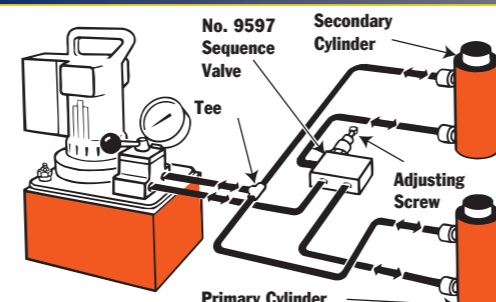

Basic single-acting system with a hand pump, gauge, hose and single-acting cylinder.

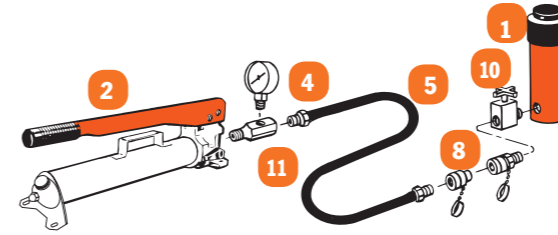

- 1 Cylinder – applies hydraulic force.
- 2 Pump – a device for converting mechanical energy to fluid energy.
- 3 Directional valve – controls the direction of hydraulic fluid in the system.
- 4 Gauge – measures bar pressure and/or force.
- 5 Hose – transports hydraulic fluid.
- 6 Manifold – allows distribution of hydraulic fluid from one source to several cylinders. (No. 9617)
- 7 Swivel Connector – allows proper alignment of valves and/or gauges. Used when units being connected cannot be rotated. (No. 10469)
- 8 Quick Coupling – “hose half” and “cylinder half” couplings are used for quick connection and fluid flow check when separated. (No. 9797 and 9798)
- 9 Shut-Off Valve – regulates the flow of hydraulic fluid to or from cylinders. (No. 9642 or 9644)
- 10 Load-Lowering Valve – allows metered lowering of cylinder and provides safety when prolonged load holding is required. (No. 9596)
- 11 Tee Gauge Adapter – allows for installation of pressure/tonnage gauge anywhere in the hydraulic system. (No. 9670)
- 12 Pipe Plug – for blocking unused ports within the system. (No. 9687)

Basic single-acting system with a hand pump, gauge, hose, multiple shut-off valves, load-lowering valves and multiple cylinders.

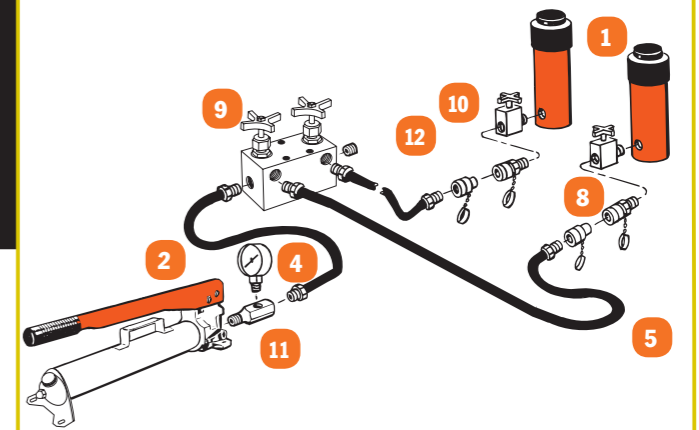

Basic double-acting system with an electric/hydraulic pump, shut-off valves, load-lowering valves and multiple double-acting cylinders.

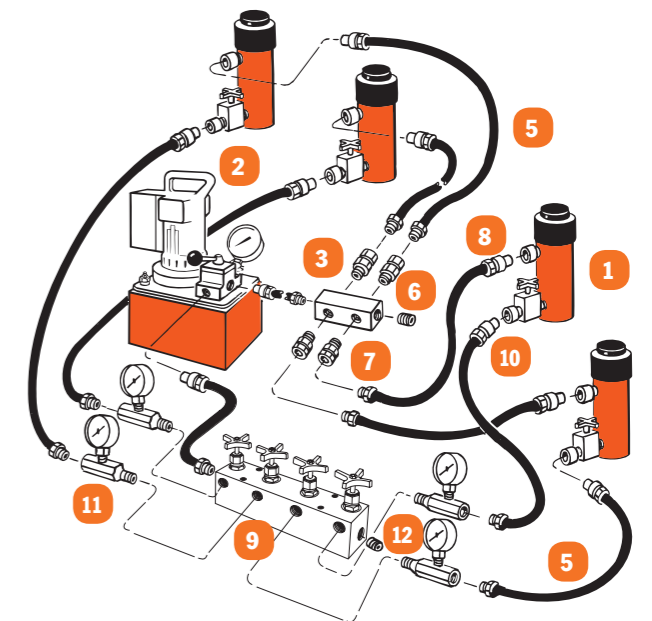

Selection Chart - Choose the right cylinder

Order No.	Collar Thread	Base Mount. hole	Type of return	Retracted		Duty	High
				Stroke mm.	Height mm.		
SA and DA action		Type		Base Mount.		Collar Thread	

2		127	233		High	-	✓	RP25
5 pull		139,7	302		High	-	✓	RP55
5		25,4	111		High	✓	✓	C51C
		82,6	165		High	✓	✓	C53C
		133,4	216		High	✓	✓	C55C
		133,4	267		High	-	✓	C55CBT
		184,2	273		High	✓	✓	C57C
		235	324		High	✓	✓	C59C
		14,3	41		High	✓	-	RLS50
10		257,2	349		High	✓	✓	C1010C
		257,2	394		High	-	✓	C1010CBT
		308	400		High	✓	✓	C1012C
		358,8	451		High	✓	✓	C1014C
		25,4	92		High	✓	✓	C101C
		54	121		High	✓	✓	C102C
		104,8	172		High	✓	✓	C104C
		155,6	248		High	✓	✓	C106C
		155,6	292		High	-	✓	C106CBT
		206,4	299		High	✓	✓	C108C
		254	391	◆	High	✓	✓	RD1010
		158,8	297	◆	High	✓	✓	RD106
		63,5	133		High	✓	-	RH102
		203,2	287		High	✓	-	RH108
		11,1	45		High	✓	-	RLS100
		38,1	89		High	-	-	RSS101
	12		7,9	56		High	✓	✓
		41,3	122		High	-	✓	RH121
		41,3	122		High	-	✓	RH121T
		76,2	184		High	-	✓	RH123
		257,2	373		High	✓	✓	C1510C
15		308	424		High	✓	✓	C1512C
		358,8	475		High	✓	✓	C1514C
		406,4	522		High	✓	✓	C1516C
		25,4	124		High	✓	✓	C151C
		54	149		High	✓	✓	C152C
		104,8	200		High	✓	✓	C154C
		155,6	271		High	✓	✓	C156C
		206,4	322		High	✓	✓	C158C
17,5		50,8	175		High	✓	-	RT172
		54	162		High	-	-	RA202
		104,8	213		High	-	-	RA204
		155,6	264		High	-	-	RA206
20		50,8	156		High	✓	✓	RH202
		76,2	154		High	✓	-	RH203
		152,4	308		High	✓	✓	RH206
		11,1	51		High	✓	-	RLS200
		44,5	95		High	-	-	RSS202
		260,4	375		High	✓	✓	C2510C
		311,2	425		High	✓	✓	C2512C
25		362	476		High	✓	✓	C2514C
		362	543		High	-	✓	C2514CBT
		25,4	140		High	✓	✓	C251C
		50,8	165		High	✓	✓	C252C
		101,6	216		High	✓	✓	C254C
		158,8	273		High	✓	✓	C256C
		158,8	314		High	-	✓	C256CBT
		209,6	324		High	✓	✓	C258C
		362	518	◆	High	✓	✓	RD2514
		158,8	340	◆	High	✓	✓	RD256

Order No.	Collar Thread	Base Mount. hole	Type of return	Retracted		Duty	High
				Stroke mm.	Height mm.		
SA and DA action		Type		Base Mount.		Collar Thread	

30		54	187		High	-	-	RA302
		104,8	238		High	-	-	RA304
		155,6	289		High	-	-	RA306
		257,2	438	◆	High	-	✓	RH3010
		63,5	159		High	✓	✓	RH302
		76,2	179	◆	High	✓	-	RH303
		152,4	248		High	✓	✓	RH306
		152,4	281	◆	High	✓	-	RH306D
		149,2	283		High	-	-	RHA306
		12,7	59		High	✓	-	RLS300
		61,9	117		High	-	-	RSS302
50		63,5	214		High	✓	-	RT302
		76,2	181		High	✓	✓	RH503
		15,9	67		High	✓	-	RLS500S
		60,3	127		High	-	-	RSS502
		76,2	268		High	✓	-	RT503
		260,4	384		High	✓	✓	C5510C
		336,6	460		High	✓	✓	C5513C
		50,8	175		High	✓	✓	C552C
		108	232		High	✓	✓	C554C
		158,8	283		High	✓	✓	C556C
		254	329	Load	-	-	-	R5510C
55		254	365	Load	-	-	-	R5510L
		50,8	125	Load	-	-	-	R552C
		50,8	162	Load	-	-	-	R552L
		152,4	264	Load	-	-	-	R556C
		152,4	321	Load	-	-	-	R556L
		254	384		High	✓	-	RA5510
		54	171		High	-	-	RA552
		104,8	222		High	-	-	RA554
		155,6	273		High	✓	-	RA556
		155,6	318		High	-	-	RA556L
		50	125	Load	High	-	-	RC0552P
60		333,4	504	◆	High	✓	✓	RD5513
		463,6	657	◆	High	✓	✓	RD5518
		158,8	329	◆	High	✓	✓	RD556
		257,2	459	◆	High	-	✓	RH6010
		76,2	235		High	✓	✓	RH603
		127	241	◆	High	✓	-	RH605
		152,4	318		High	✓	✓	RH606
		101,6	241	◆	High	✓	-	RHA604D
		333,4	492		High	-	✓	C7513C
		155,6	314		High	-	✓	C756C
		15,9	79		High	✓	-	RLS750S
75		333,4	518	◆	High	✓	✓	RD8013
		260,4	429		High	-	✓	C10010C
		50,8	219		High	-	✓	C1002C
		168,3	337		High	-	✓	C1006C
		254	343	Load	-	-	-	R10010C
		254	372	◆	-	-	-	R10010D
		254	387	Load	-	-	-	R10010L
		50,8	140	Load	-	-	-	R1002C
		50,8	169	◆	-	-	-	R1002D
		50,8	184	Load	-	-	-	R1002L
		152,4	241	Load	-	-	-	R1006C
100		152,4	270	Load	-	-	-	R1006D
		152,4	286	Load	-	-	-	R1006L
		54	197		High	-	-	RA1002
		158,8	298		High	-	-	RA1006

Order No.	Collar Thread	Base Mount. hole	Type of return	Retracted		Duty	High
				Stroke mm.	Height mm.		
SA and DA action		Type		Base Mount.		Collar Thread	

100		158,8	340	Load	High	-	-	RA1006L
		45	137	Load	High	-	-	RC1002P
		333,4	515	◆	High	✓	✓	RD10013
		511,2	718	◆	High	✓	✓	RD10020
		168,3	350	◆	High	✓	✓	RD1006
		38,1	165	◆	High	-	-	RH1001
		260,4	503	◆	High	-	✓	RH10010
		76,2	254		High	-	-	RH1003
		152,4	314	◆	High	✓	-	RH1006
		15,9	86		High	✓	-	RLS1000S
		57,2	140		High	-	-	RSS1002
150		38,1	144	◆	High	-	-	RSS1002D
		123,8	384	◆	High	✓	-	RT1004
		254	365	Load	-	-	-	R15010C
		254	392	◆	-	-	-	R15010D
		254	410	Load	-	-	-	R15010L
		50,8	162	Load	-	-	-	R1502C
		50,8	189	◆	-	-	-	R1502D
		50,8	206	Load	-	-	-	R1502L
		152,4	264	Load	-	-	-	R1506C
		152,4	291	◆	-	-	-	R1506D
		152,4	308	Load	-	-	-	R1506L
155		333,4	543	◆	High	✓	✓	RD15013
		460,4	674	◆	High	✓	✓	RD15018
		168,3	378	◆	High	✓	✓	RD1506
		127	308	◆	High	-	-	RH1505
		203,2	349	◆	High	-	-	RH1508
		14,3	102		High	✓	-	RLS1500S
		45	148	Load	High	-	-	RC1552P
		254	394	Load	-	-	-	R20010C
		254	410	◆	-	-	-	R20010D
		254	445	Load	-	-	-	R20010L
		50,8	191	Load	-	-	-	R2002C
200		50,8	207	◆	-	-	-	R2002D
		50,8	241	Load	-	-	-	R2002L
		152,4	292	Load	-	-	-	R2006C
		152,4	308	◆	-	-	-	R2006D
		152,4	343	Load	-	-	-	R2006L
		333,4	572	◆	High	✓	✓	RD20013
		460,4	724	◆	High	✓	✓	RD20018
		168,3	406	◆	High	✓	✓	RD2006
		203,2	408		High	✓	-	RH2008
		45	155	Load	High	-	-	RC2402P
		76,2	290		High	-	-	RSS2503
240		254	394	Load	-	-	-	R28010C
		254	437	◆	-	-	-	R28010D
		254	451	Load	-	-	-	R28010L
		50,8	191	Load	-	-	-	R2802C
		50,8	234	◆	-	-	-	R2802D
		50,8	248	Load	-	-	-	R2802L
		152,4	292	Load	-	-	-	R2806C
		152,4	335	◆	-	-	-	R2806D
		152,4	349	Load	-	-	-	R2806L
		330,2	617	◆	High	✓	✓	RD30013
		152,4	439	◆	High	✓	✓	RD3006
300		254	435	Load	-	-	-	R35510C
		254	550	◆	-	-	-	R35510D
		254	495	Load	-	-	-	R35510L
355		50,8	232	Load	-	-	-	R3552C

Order No.	Collar Thread	Base Mount. hole	Type of return	Retracted		Duty	High
				Stroke mm.	Height mm.		
SA and DA action		Type		Base Mount.		Collar Thread	

355		50,8	290	◆	-	-	-	R3552D
		50,8	292	Load	-	-	-	R3552L
		152,4	333	Load	-	-	-	R3556C
380		152,4	448	◆	-	-	-	R3556D
		152,4	394	Load	-	-	-	R3556L
		45	178	Load	High	-	-	RC3802P
400		330,2	651	◆	High	✓	✓	RD40013
		152,4	473	◆	High	✓	✓	RD4006
430		254	467	Load	-	-	-	R43010C
		254	516	◆	-	-	-	R43010D
		254	537	Load	-	-	-	R43010L
		50,8	264	Load	-	-	-	R4302C
		50,8	313	◆	-	-	-	R4302D
		50,8	333	Load	-	-	-	R4302L
		152,4	365	Load	-	-		

General Purpose CYLINDERS C SERIES

5-100 TONS
General Purpose, Single Acting, Spring-Return

Rugged, high quality cylinder used for lifting and pressing

CYLINDERS

RUGGED, HIGH QUALITY CYLINDER USED FOR LIFTING AND PRESSING

- Aluminum bronze bearing reduces wear caused by off-center loads.
- Maximum sized springs speed piston return and increase spring life.
- Solid steel cylinder body for durability.
- Chrome plated piston rod resists wear and corrosion.
- Wide range of accessories available to thread onto piston rod, collar, or onto cylinder base.
- Base mounting holes standard on 5 through 55 ton cylinders; optional on 75 and 100 ton cylinders.
- A 3/8" NPTF female half coupler is standard.

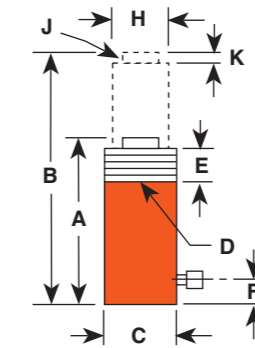

Base mounting holes page 233.

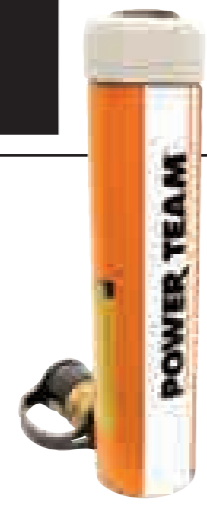

BASE MOUNTING HOLES



Cylinder Tonnage	No. Holes	Thread Size	Thread Depth	Bolt Circle Diameter (mm)
5	2†	1/4-20	9.5	25.4
10		5/16-18		39.7
15		3/8-16	12.7	47.6
25		1/2-13	19.1	58.7
55	4	3/4-10	25.4	95.3
*Optional 75				114.3
*Optional 100				120.7

* Consult Factory (45° from coupler) † 90° from coupler.

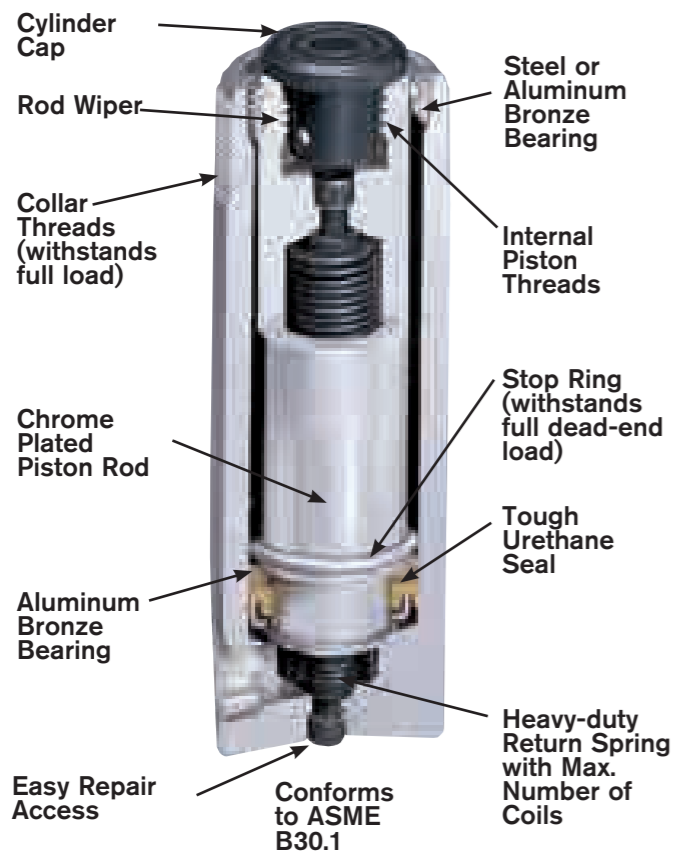

Cyl Cap Stroke Tons (mm)	Order No.	Oil Cap. (cm³)	Re-tracted Height (mm)	Ex-tended Height (mm)	Outside Dia. (mm)	Collar Thread (in.)	Piston Collar Length (mm)	Base to Rod Dia. (mm)	Piston Rod Int. Thread and Depth (mm)	Rod Protru-sion (mm)	Bore Dia. (mm)	Cylinder Effective Area (cm²)	Metric Tons at 700 (bar)	Weight (kg)	
															A
25.4	C51C	18	110.3	138.1	38.1	1 1/2-16	28.6	19.1	25.4	3/4-16 x 15.9	6.4	28.6	6.4	4.5	1.0
82.6	C53C	52	165.1	247.7	38.1	1 1/2-16	28.6	19.1	25.4	3/4-16 x 15.9	6.4	28.6	6.4	4.5	1.5
133.4	C55C	85	215.9	349.3	38.1	1 1/2-16	28.6	19.1	25.4	3/4-16 x 15.9	6.4	28.6	6.4	4.5	1.8
184.2	C57C	118	273.1	457.2	38.1	1 1/2-16	28.6	19.1	25.4	3/4-16 x 15.9	6.4	28.6	6.4	4.5	2.3
235.0	C59C	151	323.9	558.8	38.1	1 1/2-16	28.6	19.1	25.4	3/4-16 x 15.9	6.4	28.6	6.4	4.5	2.6
25.4	C101C	36	92.1	117.5	57.2	2 1/4-14	28.6	19.1	38.1	1-8 x 19.1	6.4	42.8	14.4	10.2	1.8
50.8	C102C	79	122.0	172.8	57.2	2 1/4-14	28.6	19.1	38.1	1-8 x 19.1	6.4	42.8	14.4	10.2	2.3
104.8	C104C	151	171.5	276.2	57.2	2 1/4-14	28.6	19.1	38.1	1-8 x 19.1	6.4	42.8	14.4	10.2	3.0
155.6	C106C	225	247.7	403.2	57.2	2 1/4-14	28.6	19.1	38.1	1-8 x 19.1	6.4	42.8	14.4	10.2	4.3
206.4	C108C	362	298.5	504.8	57.2	2 1/4-14	28.6	19.1	38.1	1-8 x 19.1	6.4	42.8	14.4	10.2	5.0
257.2	C1010C	370	349.3	606.4	57.2	2 1/4-14	28.6	19.1	38.1	1-8 x 19.1	6.4	42.8	14.4	10.2	5.9
308.0	C1012C	444	400.1	708.0	57.2	2 1/4-14	28.6	19.1	38.1	1-8 x 19.1	6.4	42.8	14.4	10.2	6.6
358.8	C1014C	518	450.9	809.6	57.2	2 1/4-14	28.6	19.1	38.1	1-8 x 19.1	6.4	42.8	14.4	10.2	7.3
406.4	C1016C	592	520.7	927.1	57.2	2 1/4-14	28.6	19.1	38.1	1-8 x 19.1	6.4	42.8	14.4	10.2	8.4
25.4	C151C	51	123.8	149.2	69.9	2 3/4-16	28.6	19.1	44.5	1-8 x 19.1	6.4	50.8	20.3	14.2	3.4
54.0	C152C	110	149.2	203.2	69.9	2 3/4-16	28.6	19.1	44.5	1-8 x 19.1	6.4	50.8	20.3	14.2	4.0
104.8	C154C	211	200.0	304.8	69.9	2 3/4-16	28.6	19.1	44.5	1-8 x 19.1	6.4	50.8	20.3	14.2	5.2
155.6	C156C	315	271.4	427.0	69.9	2 3/4-16	28.6	19.1	44.5	1-8 x 19.1	6.4	50.8	20.3	14.2	6.9
206.4	C158C	418	322.2	528.6	69.9	2 3/4-16	28.6	19.1	44.5	1-8 x 19.1	6.4	50.8	20.3	14.2	8.1
257.2	C1510C	521	373.0	630.2	69.9	2 3/4-16	28.6	19.1	44.5	1-8 x 19.1	6.4	50.8	20.3	14.2	9.4
308.0	C1512C	625	423.8	731.8	69.9	2 3/4-16	28.6	19.1	44.5	1-8 x 19.1	6.4	50.8	20.3	14.2	10.5
358.8	C1514C	728	474.6	833.4	69.9	2 3/4-16	28.6	19.1	44.5	1-8 x 19.1	6.4	50.8	20.3	14.2	11.8
406.4	C1516C	824	522.3	928.7	69.9	2 3/4-16	28.6	19.1	44.5	1-8 x 19.1	6.4	50.8	20.3	14.2	12.8
25.4	C251C	84	139.7	165.1	85.7	3 5/16-12	49.2	25.4	57.2	1 1/2-16 x 25.4	9.5	65.1	33.2	23.4	5.4
50.8	C252C	169	164.5	215.3	85.7	3 5/16-12	49.2	25.4	57.2	1 1/2-16 x 25.4	9.5	65.1	33.2	23.4	6.3
101.6	C254C	338	215.9	317.5	85.7	3 5/16-12	49.2	25.4	57.2	1 1/2-16 x 25.4	9.5	65.1	33.2	23.4	8.0
158.8	C256C	528	273.1	431.8	85.7	3 5/16-12	49.2	25.4	57.2	1 1/2-16 x 25.4	9.5	65.1	33.2	23.4	9.8
209.6	C258C	697	323.9	533.4	85.7	3 5/16-12	49.2	25.4	57.2	1 1/2-16 x 25.4	9.5	65.1	33.2	23.4	11.6
260.4	C2510C	865	374.4	635.0	85.7	3 5/16-12	49.2	25.4	57.2	1 1/2-16 x 25.4	9.5	65.1	33.2	23.4	13.3
311.2	C2512C	1.036	425.5	736.0	85.7	3 5/16-12	49.2	25.4	57.2	1 1/2-16 x 25.4	9.5	65.1	33.2	23.4	15.0
362.0	C2514C	1.205	476.3	838.2	85.7	3 5/16-12	49.2	25.4	57.2	1 1/2-16 x 25.4	9.5	65.1	33.2	23.4	16.7
50.8	C552C	362	174.6	225.4	127.0	5-12	55.6	34.9	79.4	-	3.2	95.3	71.2	50.1	14.7
108.0	C554C	769	231.8	339.7	127.0	5-12	55.6	34.9	79.4	-	3.2	95.3	71.2	50.1	18.7
158.8	C556C	1.131	282.6	441.3	127.0	5-12	55.6	34.9	79.4	-	3.2	95.3	71.2	50.1	23.1
260.4	C5510C	1.853	384.2	644.5	127.0	5-12	55.6	34.9	79.4	-	3.2	95.3	71.2	50.1	30.4
336.6	C5513C	2.398	460.4	796.9	127.0	5-12	55.6	34.9	79.4	-	3.2	95.3	71.2	50.1	35.3
155.6	C756C	1.596	314.3	469.9	146.1	5 3/4-12	44.5	31.8	95.3	-	3.2	114.3	102.6	72.1	33.3
333.4	C7513C	3.421	492.1	825.5	146.1	5 3/4-12	44.5	31.8	95.3	-	3.2	114.3	102.6	72.1	49.6
50.8	C1002C	675	219.1	269.9	158.8	6 1/4-12	57.2	41.3	104.8	-	3.2	130.2	133.0	93.6	28.5
168.3	C1006C	2.245	336.6	504.8	158.8	6 1/4-12	57.2	41.3	104.8	-	3.2	130.2	133.0	93.6	41.2
260.4	C10010C	3.467	428.6	689.0	158.8	6 1/4-12	57.2	41.3	104.8	-	3.2	130.2	133.0	93.6	51.2

Threaded End CYLINDERS CBT SERIES

5-25 TONS
Single Acting,
Spring-Return

Threaded piston rod end and base threads accommodate accessories and adapters.

- Threaded cylinder collars, piston rod ends, and internal base threads simplify mounting.
- A 9796 3/8" NPTF female half coupler is standard with each cylinder; oil port threads are 3/8" NPTF.

C55CBT



ASME B30.1
700 BAR

C2514CBT

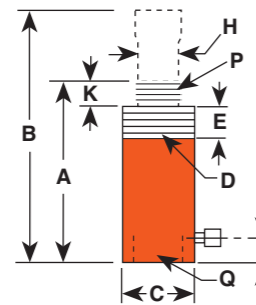

Cyl. Cap. (tons)	Stroke (mm)	Order No.	Oil Cap. (cm ³)	A Re-tracted Height (mm)	B Ex-tended Height (mm)	C Outside Dia. (mm)	D Collar Thread (in.)	E Collar Thread Length (mm)	F Base Port Dia. (mm)	H Piston Rod Dia. (in.)	K Piston Rod Protrusion (mm)	P Piston Rod Thread (NPT)	Q Internal Base Thread (NPSM) (in.)	Bore Dia. (mm)	Cyl. Eff. Area (cm ²)	Metric Tons at 700 bar	Weight (kg)
5	133,4	C55CBT	85	266,7	400,1	38,1	1 1/2-16	28,6	47,6	25,4	28,6	3/4-14	3/4-14	28,6	6,4	4,5	2,0
10	155,6	C106CBT	228	292,1	447,7	57,2	2 1/4-14	28,6	42,9	38,1	27,0	1 1/4-11 1/2	1 1/4-11 1/2	27,0	14,4	10,2	4,7
	257,2	C1010CBT	375	393,7	650,9	57,2	2 1/4-14	28,6	42,9	38,1	27,0	1 1/4-11 1/2	1 1/4-11 1/2	27,0	14,4	10,2	6,3
25	158,8	C256CBT	528	339,7	498,5	85,7	3 5/16-12	49,2	47,6	57,2	47,6	2-11 1/2	2-11 1/2	47,6	33,3	23,4	11,1
	362,0	C2514CBT	1205	542,9	904,9	85,7	3 5/16-12	49,2	47,6	57,2	47,6	2-11 1/2	2-11 1/2	47,6	33,3	23,4	18,2



ALUMINUM CYLINDERS RA-SERIES

20-200 TONS
Single Acting,
Spring-Return

Half the weight of equal capacity steel cylinders.

- Half the weight of steel cylinders.
- Aluminum body resists sparking in explosive environments.
- Hard coated aluminum piston rod and cylinder bore resist wear and corrosion.
- Grooved piston top helps keep the load from sliding on top of piston.
- Designed for jacking and other non- production operations.

RA552



ASME B30.1
700 BAR

RA1006

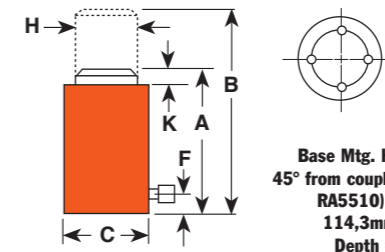

Cyl. Cap. (tons)	Stroke (mm)	Order No.	Oil Cap. (cm ³)	A Retracted Ht. (mm)	B Extended Ht. (mm)	C Outside Dia. (mm)	F Base to Port (mm)	H Piston Rod Dia. (mm)	K Piston Rod Protrusion (mm)	Bore Dia. (mm)	Cylinder Effective Area (cm ²)	Metric Tons at 700 bar	Weight (kg)
20	54,0	RA202	154	161,9	215,9	95,3	31,8	50,8	7,9	60,3	28,6	20,1	3,5
	104,8	RA204	300	212,7	317,5	95,3	31,8	50,8	7,9	60,3	28,6	20,1	4,2
	155,6	RA206	445	263,5	419,1	95,3	31,8	50,8	7,9	60,3	28,6	20,1	5,1
30	54,0	RA302	226	187,3	241,3	108,0	31,8	63,5	9,5	73,0	41,9	29,4	5,0
	104,8	RA304	439	238,1	342,9	108,0	31,8	63,5	9,5	73,0	41,9	29,4	5,9
	155,6	RA306	652	288,9	444,5	108,0	31,8	63,5	9,5	73,0	41,9	29,4	6,8
55	54,0	RA552	386	171,5	225,4	133,4	34,9	79,4	6,4	95,3	71,2	50,1	7,3
	104,8	RA554	746	222,3	327,0	133,4	34,9	79,4	6,4	95,3	71,2	50,1	8,9
	155,6	RA556*	1.109	273,1	428,6	133,4	34,9	79,4	6,4	95,3	71,2	50,1	10,9
100	254,0	RA5510*	1.811	384,2	638,2	133,4	34,9	79,4	6,4	95,3	71,2	50,1	14,4
	54,0	RA1002	718	196,9	250,8	187,3	30,2	104,8	3,2	130,2	133,0	93,5	15,1
	158,8	RA1006*	2.116	298,5	457,2	187,3	30,2	104,8	3,2	130,2	133,0	93,5	22,6

* Equipped with carrying handles.



Low profile CYLINDERS RLS SERIES

5-150 Ton
Single-Acting,
Spring-Return

Ideal for confined areas from
41 to 101,6 mm clearance.

- Cylinder body, piston and gland nut "Power Tech" treated for corrosion and abrasion resistance (see page 8).
- Standard domed piston rod (5-30 ton) or swivel cap (50-150 ton) minimize effects of off-center loading.
- Unique heavy duty spring provides fast piston return.
- A 9796 3/8" NPTF female half coupler is standard with each cylinder (the RLS50 has a 3/8" coupler which is not angled). Oil ports are 3/8" NPTF (except the RLS50).
- Couplers on all cylinders, except RLS50, are angled upward for extra clearance.



RLS100



RLS1000S

ASME B30.1
700 BAR

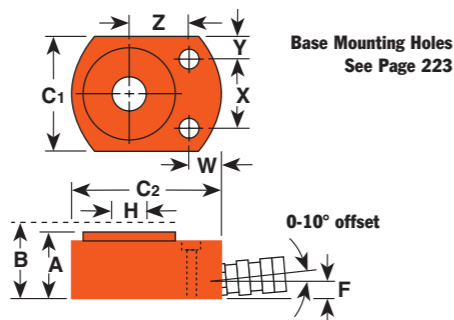

Cyl. Cap. (tons)	Stroke (mm)	Order No.	Oil Cap. (cm³)	A	B	C1 & C2	F	H	W	X	Y	Z	Bore Dia. (mm)	Cyl. Eff. Area (cm²)	Metric Tons at 700 bar	Weight (kg)
				Re-tracted Height (mm)	Ex-tended Height (mm)	Outside Dia. (mm)	Base to Port (mm)	Piston Rod Dia. (mm)	Mounting Hole Location (mm)							
5	14,3	RLS50	10	41,3	55,6	41,3x65,1	19,1	15,9	19,1	28,6	6,4	25,4	28,6	6,4	4,5	1,0
10	11,1	RLS100	17	44,5	55,6	55,6x82,6	15,9	19,1	17,5	36,5	9,5	33,3	42,9	14,4	10,1	1,5
20	11,1	RLS200	33	50,8	61,9	76,2x101,6	16,7	28,6	18,3	49,2	13,5	39,7	60,3	28,6	20,1	2,5
30	12,7	RLS300	53	58,7	71,4	95,3x114,3	18,3	34,9	20,6	52,4	21,4	44,5	73,0	41,9	29,5	3,9
50	15,9	RLS500S	99	66,7	82,6	114,3x139,7	21,4	44,5	23,8	66,7	23,8	54,0	88,9	62,1	43,6	6,3
75	15,9	RLS750S	163	79,4	95,3	140,5x165,1	25,4	54,0	23,8	76,2	32,1	65,9	114,3	102,6	72,2	10,6
100	15,9	RLS1000S	202	85,7	101,6	152,4x177,8	25,4	63,5	20,6	76,2	38,1	71,4	127,0	126,6	89,1	13,6
150	14,3	RLS1500S	282	101,6	115,9	190,5x215,9	33,3	76,2	33,3	117,5	36,5	79,4	158,8	197,9	139,2	23,6

Shorty CYLINDERS RSS SERIES

10-250 Ton
Single-Acting, Spring-Return & Double-Acting

Ideal for confined areas from
89 to 290,5 mm clearance.

- Power Tech plated piston rods and gland nuts resist scoring and corrosion.
- Heavy duty return spring (except for double-acting models) provides fast piston return & low collapsed height.
- Coupler on 10 thru 50 ton models is angled upward 5° for added clearance.
- Grooved piston top keeps load from sliding.
- Cylinders can be "dead-ended" at full capacity.
- Removable carrying handles on 100 ton and 250 ton models.



RSS2503



RSS302

ASME B30.1
700 BAR



Cribbing blocks are shown in a 30 ton RSS302 "Shorty" cylinder. For more information see pg 40.

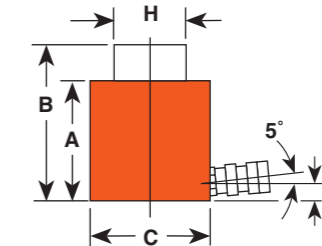

Cyl Capacity (Tons)	Stroke (mm)	Order No.	Oil Cap. (cm³)	Push Return	A	B	C	F	H	Bore Dia. (mm)	Cylinder Effective Area (cm²)	Metric Tons at 700 (bar)	Weight (kg)
					Retracted Height (mm)	Extended Height (mm)	Outside Dia. (mm)	Base to Port (mm)	Piston Rod Dia. (mm)				
10	38,1	RSS101	56	-	88,9	127,0	69,9	15,9	38,1	42,9	14,4	10,2	2,7
20	44,5	RSS202	126	-	95,3	139,7	90,5	15,9	54,8	60,3	28,6	20,0	4,5
30	61,9	RSS302	259	-	117,5	179,4	101,6	15,9	63,5	73,0	41,9	29,5	6,7
50	60,3	RSS502	374	-	127,0	187,3	123,8	19,1	79,4	88,9	62,0	43,6	10,5
100	57,2	RSS1002	725	-	139,7	196,9	168,3	23,8	111,1	127,0	126,6	89,1	21,4
100	38,1	RSS1002D	482	212	144,5	182,6	174,6	23,8 *	95,3	127,0	126,6	89,1	24,7
250	76,2	RSS2503	2.469	-	290,5	366,7	250,8	46,0	139,7	203,2	323,9	227,8	99,7

*Cylinder top to port is 40 mm
See pages 30-35 & 110-123 for hydraulic accessories.



Center Hole CYLINDERS RH SERIES

10-100 Ton Single-Acting, Spring-Return

Ideal for pulling and tensioning of cables, anchor bolts, forcing screws, etc.

- Interchangeable piston head inserts (see page 41) provide versatility of application.
- 12, 20*, 30*, 50, 60 Ton Single-Acting Models Feature Threaded Collar
- Withstands full "dead-end" loads.
- Corrosion resistant standpipe has "Power Tech" treatment.
- All cylinders except RH120 are furnished with a 9796 3/8" NPT female half coupler.
- Aluminum cylinder body and piston are featured on the RHA306 cylinder.

* Model RH203 and RHA306 do not feature the collar thread. See the chart below.



ASME B30.1
700 BAR

10, 20, 100 Ton
Single-Acting Models
Feature Plain Collar

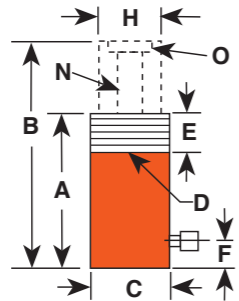

Cyl. Cap. (tons)	Stroke (mm)	Order No.	Oil Cap. (cm ³)	A	B	C	D	E	F	H	N	O	Mount. Holes Bolt Circle	Cylinder Effective Area (cm ²)	Metric Tons at 700 bar	Weight (kg)
				Re-tracted Height (mm)	Ex-tended Height (mm)	Outside Dia. (mm)	Collar Thread (in.)	Base to Rod Dia. (mm)	Piston Rod Dia. (mm)	Center Hole Dia. (mm)	Insert and Size (in.)					
10	63,5	RH102	91	134,9	198,4	76,2	-	-	25,4	52,4	19,4	1 3/4-12	1/4-20 x 60,3	14,3	10,0	4,1
10	203,2	RH108	290	287,3	490,5	76,2	-	-	25,4	52,4	19,4	1 3/4-12	1/4-20 x 60,3	14,3	10,0	8,5
12	7,9	RH120**	14	55,6	63,5	69,9	2 3/4-16	31,8	9,5	34,9	17,5	3/4-16	5/16-18 x 50,8	17,8	12,5	1,4
12	41,3	RH121	74	122,2	163,5	69,9	2 3/4-16	31,8	25,4	34,9	20,2	-	-	17,8	12,5	3,0
12	41,3	RH121T**	74	122,2	163,5	69,9	2 3/4-16	31,8	25,4	34,9	17,5	3/4-16	5/16-18 x 50,8	17,8	12,5	3,0
12	76,2	RH123	136	184,2	260,4	69,9	2 3/4-16	20,6	25,4	34,9	20,6	-	-	17,8	12,5	4,0
20	50,8	RH202	155	155,6	206,4	98,4	3 7/8-12	38,1	25,4	54,0	27,4	1 1/2-16	3/8-16 x 82,6	30,4	21,4	7,3
20	76,2	RH203	193	154,0	230,2	101,6	-	-	25,4	69,9	26,6	2 1/4-12	3/8-16 x 82,6	25,3	17,8	9,1
20	152,4	RH206	465	308,0	460,4	98,4	3 7/8-12	38,1	25,4	54,0	27,4	1 1/2-16	3/8-16 x 82,6	30,4	21,4	13,7
30	63,5	RH302	260	158,8	222,3	120,7	4 3/4-12	38,1	29,4	82,6	32,9	2 1/4-12	7/16-20 x 92,1	40,9	28,8	11,6
30	149,2	RHA306	625	283,4	432,6	130,2	-	-	31,8	82,6	32,5	2 5/8-8	7/16-20 x 92,1	40,9	28,8	9,9
30	152,4	RH306	625	247,7	400,1	120,7	4 3/4-12	38,1	29,4	82,6	32,5	2 1/4-12	-	40,9	28,8	17,7
50	76,2	RH503	534	181,0	257,2	152,4	6-12	50,8	31,8	104,8	42,5	3 1/4-12	5/8-18 x 120,7	70,0	49,3	21,2
60	76,2	RH603*	607	235,0	311,2	158,8	6 1/4-12	63,5	25,4	91,3	54,0	3-12	1/2-13 x 130,2	79,4	55,9	27,2
60	152,4	RH606*	1.211	311,2	463,6	158,8	6 1/4-12	63,5	25,4	91,3	54,0	3-12	1/2-13 x 130,2	79,4	55,9	35,4
100	76,2	RH1003*	1.014	254,0	330,2	212,7	-	-	31,8	127,0	79,4	4 1/4-12	-	133,0	93,5	52,2

* Supplied with carrying handles.

Aluminum

** RH120 and RH121T do not have an internal threaded insert, but do have a 3/4-16 internal thread. The RH120 inlet port is 1/4" NPTF.

Center Hole CYLINDERS RH SERIES

30-200 Ton Double-Acting

Ideal for pulling and tensioning of cables, anchor bolts, forcing screws.

- Interchangeable piston head inserts (see page 41) provide versatility of application.
- Built-in safety feature prevents over-pressurization of the retract circuit.
- Plated piston rod resists wear; superior packings provide high cycle life without leakage.
- Corrosion-resistant standpipe has "Power Tech" treatment (see page 8).
- Each cylinder has 9796 3/8" NPTF female half couplers. The 60 ton thru 200 ton steel models are equipped with removable carrying handles.

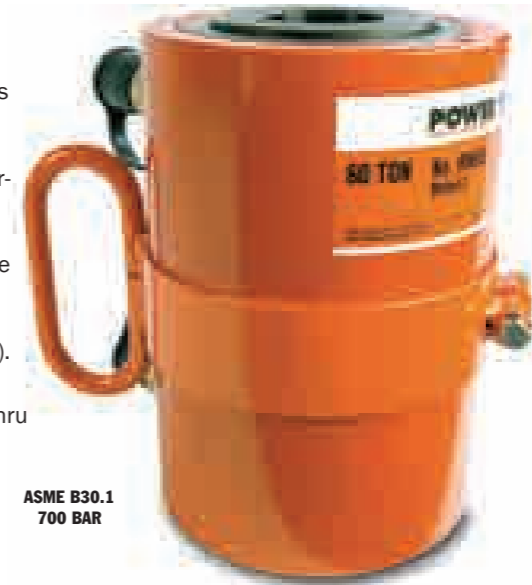

ASME B30.1
700 BAR



CYLINDERS

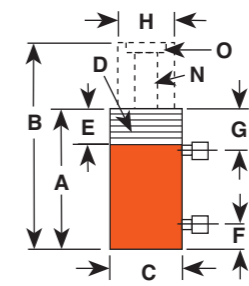
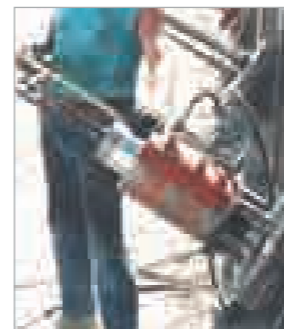

Cyl. Cap. (tons)	Stroke (mm)	Order No.	Oil Cap. (cm ³)	A	B	C	D	E	F	G	H	N	O	Mounting Holes (in.) and Bolt Circle (mm)	Cylinder Effective Area (cm ²)	Metric Tons at 700 bar	Weight (kg)			
				Re-tracted Height (mm)	Ex-tended Height (mm)	Outside Dia. (mm)	Collar Thread (in.)	Base to Rod Dia. (mm)	Piston Rod Dia. (mm)	Center Hole Dia. (mm)	Insert Size (in.)									
30	15	RH303	289	167	179,4	255,6	120,7	-	-	25,4	41,3	63,5	32,5	2-12	3/8-16 x 92,1	38,0	21,8	26,8	15,3	13,5
30	15	RH306D	580	333	281,0	433,4	120,7	-	-	25,4	41,3	63,5	32,5	2-12	7/16-20 x 92,1	38,0	21,8	26,8	15,3	20,4
30	20	RH3010	1.082	672	438,2	695,3	114,3	4 3/4-12	41	44,5	81,0	60,3	33,3	1 7/8-16	-	42,2	26,1	29,7	18,3	27,7
60	25	RHA604D	807	338	241,3	342,9	177,8	-	-	39,7	57,2	101,6	54,0	3-12	1/2-13 x 130,2	79,4	33,2	55,8	25,1	16,2
60	25	RH605*	1.009	423	241,3	368,3	165,9	-	-	25,4	44,5	101,6	54,0	3-12	1/2-13 x 130,2	79,4	33,2	55,8	25,1	33,1
60	40	RH6010*	2.181	1.427	458,8	716,0	158,8	6 3/4-12	47,6	54,0	81,8	92,1	54,4	3-16	-	84,8	55,4	59,6	38,9	54,5
100	45	RH1001*	526	233	165,1	203,2	212,7	-	-	31,8	58,7	127,0	79,8	4-16	5/8-11 x 177,8	138,0	60,8	97,0	42,7	38,6
100	50	RH1006*	1.971	1.076	314,3	466,7	184,2	-	-	37,3	59,1	111,1	52,4	-	1/2-13 x 139,7	129,2	70,5	90,8	49,6	43,1
100	45	RH10010*	3.552	1.556	495,3	752,5	215,9	8 1/2-12	57	63,5	91,7	139,7	79,8	4 1/2-12	-	138,0	60,8	97,0	42,7	109,0
150	70	RH1505*	2.475	1.207	311,2	438,2	215,9	-	-	37,3	68,3	139,7	65,1	-	-	194,1	94,8	136,9	66,8	67,2
150	75	RH1508*	3.929	2.086	349,3	552,5	247,7	-	-	39,3	61,1	152,4	80,2	5-12	-	193,2	102,6	135,9	72,1	103,1
200	75	RH2008*	5.307	2.093	408,0	611,2	273,1	-	-	57,2	81,8	190,5	103,2	6-12	1 1/4-12 x 198,1	260,9	102,9	183,5	72,4	142,0

* Supplied with carrying handles.

† Measured with 19 mm high serrated insert installed. See pages 36-41 & 120-133 for hydraulic accessories.

Aluminum



Center Hole CYLINDERS RT SERIES

17½-100 Ton
Single- Acting, Spring-
Return & Double-Acting

Ideal for pulling and pressing.



ASME B30.1
700 BAR

- A proven design; used throughout industry for over 40 years.
- Cylinders withstand full “dead-end” loads.
- Compact design; ideal for applications in which space is limited.
- Basic head can be changed from a tapped hole to plain hole by simply changing insert. (See page 41)
- Pistons have “Power Tech” treatment for corrosion and abrasion resistance.

RT 302

Dimensions for reference only. Single-Acting, Spring-Return Cylinders

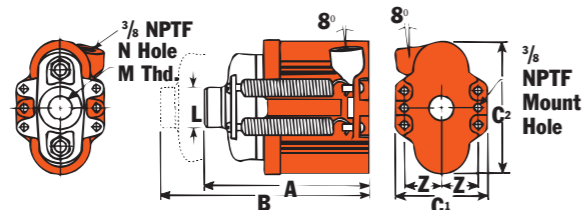

Double-Acting Cylinder (RT1004)

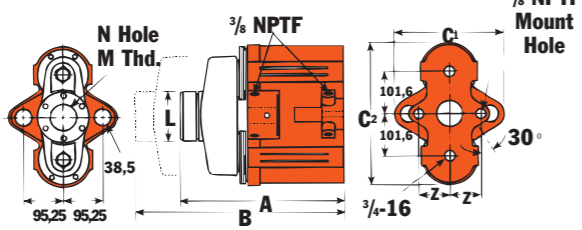

RT 1004



RP25

RP55

ASME B30.1
700 BAR

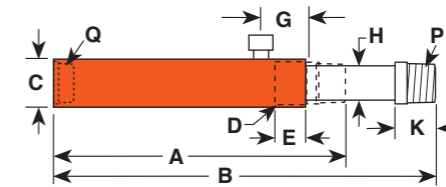

Pulling CYLINDERS RP SERIES

2 & 5 Ton
Single-Acting,
Spring-Return

Designed for pulling and tensioning.

- Heavy duty compression spring provides long cycle life and rapid extension of piston.
- Spring automatically extends piston rod when pump pressure is released.

CYLINDERS

CYLINDERS

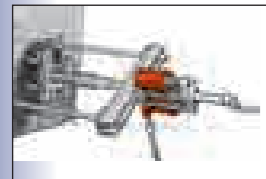

Cyl. Capacity (Tons)	Stroke (mm)	Order No.	Oil Cap. (cm³)	Dimensions (mm)									Cyl. Mounting Hole (mm)	Metric Area (cm²)	Tons at 700 bar	Weight (kg)
				A	B	C1	C2	L	M	N	Z					
17,5	50,8	RT172	116	-	174,6	225,4	95,3	146,1	44,5	1-8	27,0	38,1	8,7	22,8	16,1	6,6
30	63,5	RT302	258	-	214,3	277,8	108,0	190,5	57,2	1 ¼-7	32,9	46,0	11,9	40,5	28,5	12,8
50	76,2	RT503	482	-	268,3	344,5	149,2	238,1	73,0	1 ½-5 ½	42,5	60,3	16,7	63,3	44,5	25,4
100	123,8	RT1004**	1.583	1.037	384,2	508,0	266,7	336,6	120,7	2 ½-8	65,1	73,0	19,8	124,1*	87,3	72,6

* Push side only.

** The RT1004 has a bypass when full stroke is reached, preventing over-pressurization of the cylinder.

NOTE: Each cylinder complete with threaded cylinder head insert, cylinder half coupler and cylinder attaching screws.

Cyl. Cap. (Tons)	Stroke (mm)	Order No.	Oil Cap. (cm³)	A Re-tracted Height (mm)	B Ex-tended Height (mm)	C Outside Dia. (mm)	D Collar Thread (in.)	E Collar Thread Length (mm)	G Cylinder Top Port (mm)	H Piston Rod Dia. (mm)	K Piston Rod Protrusion (mm)	P Piston Rod Thread (NPTF)	Q Piston Base Thread (NPTF)	Bore Dia. (mm)	Cyl. Eff. Area (cm²)	Metric Tons at 700 bar	Weight (kg)
2	127,0	RP25	45	242,9	379,9	44,5	1 ½-16	25,4	42,9	19,1	25,4	¾-14	¾-14	28,6	3,5	2,5	1,8
5	139,7	RP55	102	301,6	441,3	57,2	2 ½-14	25,4	42,9	30,2	34,9	1 ¼-11 ½	1 ¼-11 ½	42,9	7,3	5,1	5

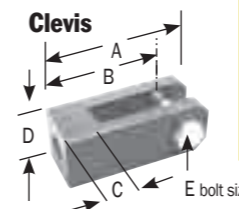

Clevis ORDERING INFORMATION

Use with Cyl No.	Order No.	A (mm)	B (mm)	C (mm)	D (mm)	E (mm)
RP25	421057*	130,3	109,5	33,3	50,8	19,1
RP55	421056**	152,4	127,0	38,1	63,5	22,4

* For base mounting, extension rod 351106 is required.

** For base mounting, extension rod 351075 is required.



Double Acting CYLINDERS RD SERIES

10-500 Ton
Double Acting,
Hydraulic-Return

High tonnage premium design
for high cycle life.

- Perfect for bridge lifting, building reconstruction, shipyard, utility and mining equipment maintenance.
- Aluminum bronze overlay bearings provide long life, chrome plated piston rod resist corrosion.
- Load cap snaps out to expose internal piston rod threads for pulling applications; threads withstand full tonnage.
- Grooved ring pattern in load cap helps guard against load slippage.
- Each cylinder has two 9796 3/8" NPTF female half couplers.
- Built-in safety relief valve prevents over-pressurization of the retract circuit.
- Feature mounting holes and collar threads.



ASME B30.1
700 BAR

RD30013

Features of RD Series Cylinders

Four special ordered 500 ton, 610 mm stroke cylinders used in a swaging press for crimping 89 mm wire rope.

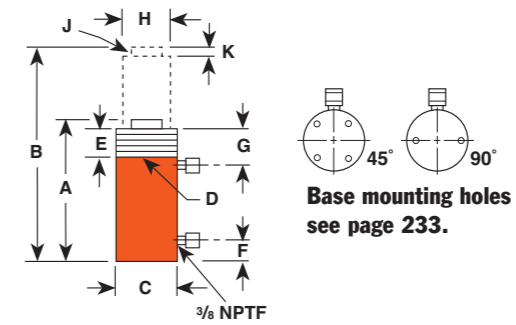
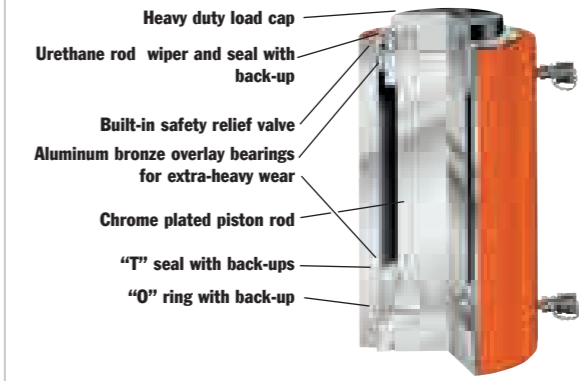

Threads withstand full load.

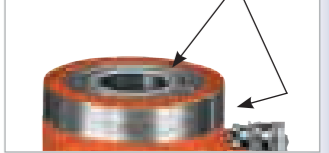

Cyl. Cap (tons)	Stroke (mm)	Order No.	Oil Capacity (cm³)		Re-tracted Height (mm)	Ex-tended Height (mm)	Out-side Dia. (mm)	Collar Thread Size (in.)	Thread Length (mm)	Base Cylinder		Piston Rod Dia. (mm)	Rod Int. Depth (mm)	Piston Rod Pro-trusion (mm)	Load Cap Dia. (mm)	Bore Dia. (mm)	Cyl. Eff. Area (cm²)		Metric Tons at 700 bar		Weight (kg)	
			Push	Pull						Port to Port (mm)	Piston Top to Port (mm)						Push	Pull	Push	Pull		
																						Push
10	4	158.8	RD106	228	90	296.9	455.6	76.2	2 1/4-12	41.3	25.4	63.5	33.3	18 x 25.4	6.4	34.9	42.9	14.4	5.7	10.2	4.0	10.0
10	4	254.0	RD1010	366	144	398.5	652.5	76.2	2 1/4-12	41.3	25.4	63.5	33.3	18 x 25.4	6.4	34.9	42.9	14.4	5.7	10.2	4.0	12.7
25	8	158.8	RD256	528	166	314.3	473.1	101.6	4-12	41.3	25.4	63.5	54.0	1 1/2-16 x 25.4	9.5	54.0	65.1	33.2	10.4	23.4	7.3	18.1
25	8	362.0	RD2514	1,205	376	517.5	879.5	101.6	4-12	41.3	25.4	63.5	54.0	1 1/2-16 x 25.4	9.5	54.0	65.1	33.2	10.4	23.4	7.3	29.5
55	28	158.8	RD556	1,132	577	329.4	488.2	127.0	5-12	41.3	33.3	63.5	66.7	1 1/4-8 x 30.2	15.9	66.7	95.3	71.2	36.3	50.1	25.6	27.9
55	28	333.4	RD5513	2,376	1,212	504.0	837.4	127.0	5-12	41.3	33.3	63.5	66.7	1 1/4-8 x 30.2	15.9	66.7	95.3	71.2	36.3	50.1	25.6	40.9
55	28	460.4	RD5518	3,280	1,673	657.2	1,117.6	127.0	5-12	41.3	33.3	63.5	66.7	1 1/4-8 x 30.2	15.9	66.7	95.3	71.2	36.3	50.1	25.6	64.5
80	44	333.4	RD8013	3,421	1,901	517.5	850.9	146.1	5 3/4-12	41.3	38.1	63.5	76.2	2 1/2 x 38.1	14.3	73.0	114.3	102.6	57.0	72.1	40.1	53.6
100	44	168.3	RD1006	2,242	959	350.0	518.3	174.6	6 7/8-12	41.3	38.1	63.5	98.4	2 3/4-12 x 29.4	15.9	98.4	130.2	133.1	57.0	93.5	40.1	57.2
100	44	333.4	RD10013	4,440	1,902	515.1	848.5	174.6	6 7/8-12	41.3	38.1	63.5	98.4	2 3/4-12 x 29.4	15.9	98.4	130.2	133.1	57.0	93.5	40.1	82.2
100	44	511.2	RD10020	6,809	2,919	718.3	1,229.5	174.6	6 7/8-12	41.3	38.1	63.5	98.4	2 3/4-12 x 29.4	15.9	98.4	130.2	133.1	57.0	93.5	40.1	118.0
150	73	168.3	RD1506	3,334	1,606	377.8	546.1	209.6	8 1/4-12	41.3	50.8	63.5	114.3	3 1/4 x 38.1	20.6	114.3	158.8	197.9	95.3	139.1	66.9	85.4
150	73	333.4	RD15013	6,604	3,180	542.9	876.3	209.6	8 1/4-12	41.3	50.8	63.5	114.3	3 1/4 x 38.1	20.6	114.3	158.8	197.9	95.3	139.1	66.9	123.5
150	73	460.4	RD15018	9,132	4,392	673.9	1,134.3	209.6	8 1/4-12	41.3	50.8	63.5	114.3	3 1/4 x 38.1	19.1	114.3	158.8	197.9	95.3	139.1	66.9	170.7
200	113	168.3	RD2006	4,485	2,457	406.4	574.7	241.3	9 1/2-12	41.3	63.5	68.3	123.8	3 1/4 x 57.1	27.0	114.3	184.2	266.3	145.9	187.2	102.6	118.9
200	113	333.4	RD20013	8,886	4,869	571.5	904.9	241.3	9 1/2-12	41.3	63.5	68.3	123.8	3 1/4 x 57.1	27.0	114.3	184.2	266.3	145.9	187.2	102.6	161.6
200	113	460.4	RD20018	12,270	6,722	723.9	1,184.3	241.3	9 1/2-12	41.3	63.5	68.3	123.8	3 1/4 x 57.1	27.0	114.3	184.2	266.3	145.9	187.2	102.6	200.7
300	147	152.4	RD3006	5,920	2,903	488.9	591.3	273.1	10 1/2-12	60.3	85.7	85.7	158.8	2 1/2-12 x 82.5	28.6	174.6	222.3	387.8	190.0	272.7	133.6	172.5
300	147	330.2	RD30013	12,825	6,281	630.2	960.4	273.1	10 1/2-12	60.3	85.7	85.7	158.8	2 1/2-12 x 82.5	28.6	174.6	222.3	387.8	190.0	272.7	133.6	296.9
400	186	152.4	RD4006	7,724	4,051	489.7	642.1	320.7	12 1/2-8	69.9	97.6	97.6	184.2	3-12 x 92.2	31.8	198.4	254.0	506.6	240.3	356.2	169.0	265.6
400	186	330.2	RD40013	16,744	8,790	667.5	997.7	320.7	12 1/2-8	69.9	97.6	97.6	184.2	3-12 x 92.2	31.8	198.4	254.0	506.6	240.3	356.2	169.0	349.6
500	245	152.4	RD5006	9,774	4,838	522.3	674.7	374.7	14 1/4-8	79.4	105.6	105.6	203.2	3 1/4-12 x 107.9	38.1	215.9	285.8	641.1	317.0	450.8	222.8	371.8
500	245	330.2	RD50013	21,189	10,480	700.1	1,030.3	374.7	14 1/4-8	79.4	105.6	105.6	203.2	3 1/4-12 x 107.9	38.1	215.9	285.8	641.1	317.0	450.8	222.8	495.8



High Tonnage CYLINDERS R SERIES

55-565 Ton
Single-Acting
Load-Return

High-tonnage, low cycle,
gravity return.

CYLINDERS



R2802C
ASME B30.1
700 BAR

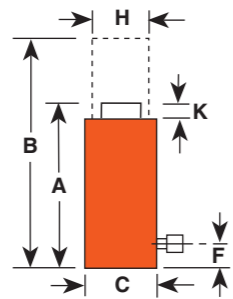

- Visible indicator band alerts when stroke limit is reached; overflow port ("weep hole") stroke limiter prevents piston from being overextended.
- Alloy heat treated piston and body for reliability and strength.
- Plated piston rod increase corrosion resistance and give superior bearing qualities.



High Tonnage CYLINDER RC SERIES

740 - 1220 Ton
Single-Acting,
Load Return

High-tonnage, low cycle,
gravity return.

CYLINDERS

Cyl. Cap. (tons)	Stroke (mm)	Order No.	Oil Cap. (cm ²)	A Retracted Ht. (mm)	B Extended Ht. (mm)	C Outside Dia. (mm)	F Base to Port (mm)	H Piston Rod Dia. (mm)	K Piston Rod Protrusion (mm)	Piston Bore Dia. (mm)	Effective Area (cm ²)	Metric Tons at 700 bar	Weight (kg)
55	50,8	R552C	362	125,4	176,2	127,0	25,4	95,3	3,2	95,3	71,2	50,1	12,3
55	152,4	R556C	1.087	227,0	379,4	127,0	25,4	95,3	3,2	95,3	71,2	50,1	22,7
55	254,0	R5510C	1.811	328,6	582,6	127,0	25,4	95,3	3,2	95,3	71,2	50,1	32,7
100	50,8	R1002C	677	139,7	190,5	165,1	25,4	130,2	3,2	130,2	133,1	93,6	23,6
100	152,4	R1006C	2.030	241,3	393,7	165,1	25,4	130,2	3,2	130,2	133,1	93,6	40,4
150	50,8	R1502C	1.007	161,9	212,7	204,8	31,8	158,8	3,2	158,8	197,9	139,1	41,8
150	152,4	R1506C	3.019	263,5	415,9	204,8	31,8	158,8	3,2	158,8	197,9	139,1	68,6
150	254,0	R15010C	5.032	365,1	619,1	204,8	31,8	158,8	3,2	158,8	197,9	139,1	95,3
200	50,8	R2002C	1.355	190,5	241,3	235,0	41,3	184,2	3,2	184,2	266,3	187,2	65,8
200	152,4	R2006C	4.062	292,1	444,5	235,0	41,3	184,2	3,2	184,2	266,3	187,2	100,3
280	50,8	R2802C	1.861	190,5	241,3	260,4	41,3	215,9	3,2	215,9	365,9	257,5	91,6
280	152,4	R2806C	5.583	292,1	444,5	276,2	41,3	215,9	3,2	215,9	365,9	257,5	136,7
355	50,8	R3552C	2.326	231,8	282,6	298,5	54,0	241,3	3,2	241,3	457,2	321,4	137,1
355	152,4	R3556C	6.975	333,4	485,8	298,5	54,0	241,3	3,2	241,3	457,2	321,4	197,0
355	254,0	R35510C	11.624	435,0	689,0	298,5	54,0	241,3	3,2	241,3	457,2	321,4	256,5
430	50,8	R4302C	2.841	263,5	314,3	330,2	63,5	266,7	3,2	266,7	558,5	392,7	199,8
430	152,4	R4306C	8.520	365,1	517,5	330,2	63,5	266,7	3,2	266,7	558,5	392,7	276,5
565	50,8	R5652C	3.710	292,1	342,9	377,8	69,9	304,8	3,2	304,8	729,5	512,9	289,7
565	152,4	R5656C	11.129	393,7	546,1	377,8	69,9	304,8	3,2	304,8	729,5	512,9	389,5
565	254,0	R56510C	18.548	495,3	749,3	377,8	69,9	304,8	3,2	304,8	729,5	512,9	489,4

Single-Acting High Tonnage Cylinders

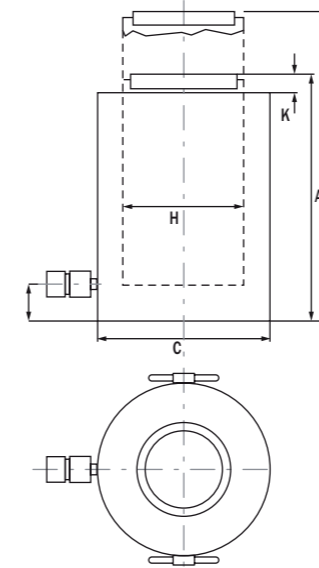

Swivel Cap

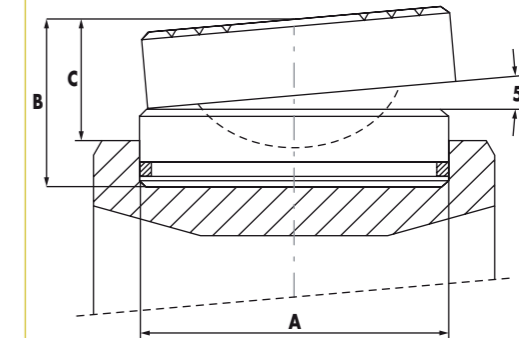

Order No.	Used with Cyl.	A mm	B mm	C mm	Product Wt. kg
2000822	RC740*C	200	79	56	19
2000823	RC965*C	249	104	76	40
2000825	RC1220*C	323	175	124	113

Cyl. Cap. (tons)	Stroke (mm)	Order No.	Oil Cap. (cm ²)	A Retracted Height (mm)	B Extended Height (mm)	C Outside Dia. (mm)	F Base to Port (mm)	H Piston Rod Dia. (mm)	K Piston Rod Protrusion (mm)	Bore Dia. (mm)	Cyl. Effective Area (cm ²)	Metric Tons @ 700 bar	Product Wt. (kg)
740	50	RC7402C	4.811	265	315	430	65	350	9	350	962	673,5	300
740	150	RC7406C	14.132	365	515	430	65	350	9	350	962	673,5	416
740	250	RC74010C	24.053	465	715	430	65	350	9	350	962	673,5	530
965	50	RC9652C	6.283	290	340	490	70	400	10	400	1.256,6	879,7	423
965	150	RC9656C	18.850	390	540	490	70	400	10	400	1.256,6	879,7	577
965	250	RC96510C	31.416	490	740	490	70	400	10	400	1.256,6	879,7	725
1220	50	RC12202C	7.952	415	465	550	80	450	10	450	1.590,4	1.113,3	766
1220	150	RC12206C	23.856	440	665	550	80	450	10	450	1.590,4	1.113,3	960
1220	250	RC122010C	39.761	615	865	550	80	450	10	450	1.590,4	1.113,3	1.147

SWIVEL CAPS
Reduce the effects of off center loading. Tilts up to 5 degrees. Radial grooves on top of cap reduce load slippage.

Use with Cyl. No.	Swivel Cap Order No.	Weight (kg)	A (mm)	B (mm)
150-200 ton	420867	4,0	38,1	130,2
280 ton	420868	6,1	44,5	149,2
355 ton	420869	16,8	69,9	195,3
430 ton	420870	23,6	79,4	225,4
565 ton	420871	35,4	92,1	250,8

Reduce the effects of off center loading. Tilts up to 5 degrees. Radial grooves on top of cap reduce load slippage. Notch across face of each cap helps keep loads having a protruding or round shaped centered.



High Tonnage CYLINDERS R SERIES

100-565 Ton
Double-Acting,
Hydraulic-Return

High-tonnage, low cycle,
hydraulic return.

- Cylinders come standard with swivel caps to reduce the effects of off-center loading.
- Cylinders may be "dead-ended" without damage.
- Hard chrome plated, heat treated piston rod reduces wear on piston and gland nut.
- Built-in safety relief valve prevents over-pressurization of the retract circuit.
- Each cylinder has two 9796 3/8" NPTF female half couplers.



R1502D



R2806D

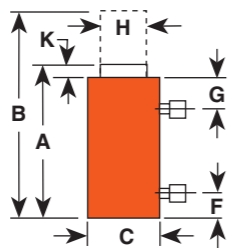

Cyl. Cap. (tons)	Stroke (mm)	Order No.	Oil Capacity (cm ³)		A Re-tracted Height (mm)	B Ex-tended Height (mm)	C Outside Dia. (mm)	F Base to Port (mm)	G Cylinder Top to Port (mm)	H Piston Rod Dia. (mm)	K Piston Rod Protrusion (mm)	Bore Dia. (mm)	Cylinder Effective Area (cm ²)	Metric Tons at 700 bar	Weight (kg)
			Push	Return											
100	50,8	R1002D	676	315	168,7	219,5	165,1	25,4	56,0	95,3	7,1	130,2	132,9	93,4	24,5
100	152,4	R1006D	2.027	945	270,3	422,7	165,1	25,4	56,0	95,3	7,1	130,2	132,9	93,4	36,8
100	254,0	R10010D	3.378	1.574	371,9	625,9	165,1	25,4	56,0	95,3	7,1	130,2	132,9	93,4	49,0
150	50,8	R1502D	1.007	485	188,9	239,7	204,8	31,8	57,2	114,3	7,5	158,8	198,0	139,1	43,1
150	152,4	R1506D	3.021	1.456	290,5	442,9	204,8	31,8	57,2	114,3	7,5	158,8	198,0	139,1	61,7
200	50,8	R2002D	1.355	643	206,8	257,6	235,0	41,3	58,7	133,4	8,7	184,2	266,4	187,2	61,7
200	152,4	R2006D	4.064	1.929	308,4	460,8	235,0	41,3	58,7	133,4	8,7	184,2	266,4	187,2	84,9
200	254,0	R20010D	6.773	3.214	410,0	664,0	235,0	41,3	58,7	133,4	8,7	184,2	266,4	187,2	108,5
280	50,8	R2802D	1.861	774	233,8	284,6	276,2	47,6	65,5	165,1	10,3	215,9	365,7	257,3	99,4
280	152,4	R2806D	5.579	2.322	335,4	447,8	276,2	47,6	65,5	165,1	10,3	215,9	365,7	257,3	134,8
280	254,0	R28010D	9.299	3.870	437,0	691,0	276,2	47,6	65,5	165,1	10,3	215,9	365,7	257,3	170,7
355	50,8	R3552D	2.326	777	288,9	339,7	298,5	54,0	69,9	196,9	11,1	241,3	457,3	321,4	147,0
355	152,4	R3556D	6.977	2.332	390,5	542,9	298,5	54,0	69,9	196,9	11,1	241,3	457,3	321,4	191,1
430	50,8	R4302D	2.840	977	312,7	363,5	330,2	63,5	75,0	215,9	11,9	266,7	558,6	392,7	199,3
430	152,4	R4306D	8.521	2.932	414,3	566,7	330,2	63,5	75,0	215,9	11,9	266,7	558,6	392,7	253,3
430	254,0	R43010D	14.202	4.887	515,9	769,9	330,2	63,5	75,0	215,9	11,9	266,7	558,6	392,7	305,5
565	50,8	R5652D	3.710	1.260	345,3	396,1	377,8	69,9	81,4	247,7	13,9	304,8	729,5	512,9	281,0
565	152,4	R5656D	11.129	3.779	446,9	599,3	377,8	69,9	81,4	247,7	13,9	304,8	729,5	512,9	350,4
565	254,0	R56510D	18.548	6.298	548,5	802,5	377,8	69,9	81,4	247,7	13,9	304,8	729,5	512,9	420,4

- Cylinders come standard with hardened caps.
- Optional swivel caps to reduce the effects of off-center loading.
- Cylinders may be "dead-ended" without damage.
- Safety relief valve prevents over-pressurization of the retract circuit.
- Each cylinder has two 9796 3/8" NPTF female half couplers.



High Tonnage CYLINDER RC SERIES

740 & 1220
Double-Acting,
Hydraulic Return

High Tonnage Cylinders
Rugged And Reliable!

Double-Acting High Tonnage Cylinders

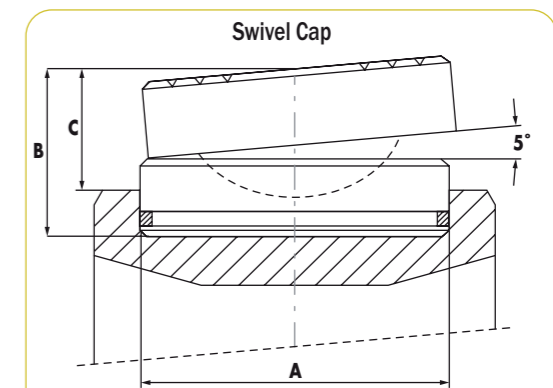
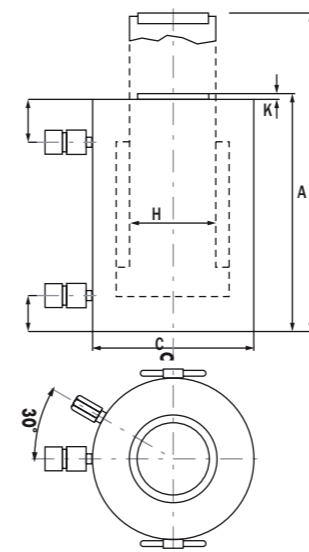

Order No.	Used with Cyl.	A mm	B mm	C mm	Product Wt. kg
2000822	RC740*D	200	79	56	19
2000823	RC965*D	249	104	76	40
2000825	RC1220*D	323	175	125	113

Cyl. Cap. (tons)	Stroke (mm)	Order No.	Oil Cap. (cm ³)	A Retracted Height (mm)	B Extended Height (mm)	C Outside Dia. (mm)	F Base to Port (mm)	G Cyl. Top to Port (mm)	H Piston Rod Dia. (mm)	K Piston Rod Protrusion (mm)	Cyl. Effective Area (cm ²)	Metric Tons at 700 bar	Product Wt.
740	50	RC7402D	4.811	283	333	430	65	100	280	9	962,0	673,5	304
740	150	RC7406D	14.132	398	548	430	65	100	280	9	962,0	673,5	398
740	250	RC74010D	24.053	508	758	430	65	100	280	9	962,0	673,5	490
965	50	RC9652D	6.283	310	360	490	70	115	320	10	1.256,6	879,7	434
965	150	RC9656D	18.850	420	570	490	70	115	320	10	1.256,6	879,7	551
965	250	RC96510D	31.416	530	780	490	70	115	320	10	1.256,6	879,7	668
1220	50	RC12202D	7.952	330	380	550	80	135	360	10	1.590,4	1.113,3	584
1220	150	RC12206D	23.856	440	590	550	80	135	360	10	1.590,4	1.113,3	731
1220	250	RC122010D	39.761	550	800	550	80	135	360	10	1.590,4	1.113,3	878



CYLINDERS

CYLINDERS

Locking Collar

CYLINDER RL SERIES- ALUMINUM

55 & 100 Ton
Single- Acting,
Spring-Return

Positive mechanical lock to support load.

CYLINDERS



Locking collar feature permits non-hydraulic support of load.



RA1006L

- Support lifted load for extended periods of time with hydraulic pressure released.
- At half the weight of steel cylinders of comparable capacity, aluminum cylinders are ideal when portability is a key factor.
- Feature carrying handle.

ASME B30.1
700 BAR



RA556L

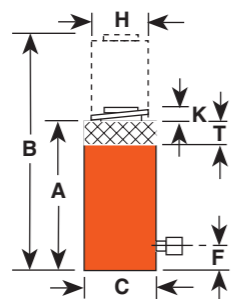

Cyl. Cap. (tons)	Stroke (mm)	Order No.	Oil Cap. (cm ³)	A Retracted Ht. (mm)	B Extended Ht. (mm)	C Outside Dia. (mm)	F Base to Port (mm)	H Piston Rod Dia. (mm)	K Piston Rod Protrusion (mm)	T Nut Thickness (mm)	Bore Dia. (mm)	Cylinder Effective Area (cm ²)	Metric Tons at 700 bar	Weight (kg)
55	155,5	RA556L	1.109	317,5	473,1	133,4	34,9	82,6	12,7	38,1	95,3	71,2	50,1	13,4
100	158,8	RA1006L	2.116	339,7	498,5	187,3	30,2	114,3	6,4	38,1	130,2	133,0	93,5	29,1

Note: Supported loads not to exceed the rated capacity of the cylinders. Not intended to support additional dynamic loads, such as those applied by moving vehicles.

Pancake Cylinders

LOCKING COLLAR RC SERIES

55 & 620 Ton
Single- Acting,
Load-Return

Positive mechanical lock to support load.

CYLINDERS

- Compact design - for use where space is limited
- Locking collar designed to support lifted load for extended periods of time with hydraulic pressure released
- Integral tilt saddle standard improves performance under side load
- Overflow port ("weep hole") prevents piston from being overextended under load.
- Special coating improves corrosion and abrasion resistance.
- Cylinders come standard with hardened caps. Optional swivel caps reduce the effects of off-center loading
- Single-Acting Locking Collar Cylinders
- Equipped with 3/8" NPTF female half couplers

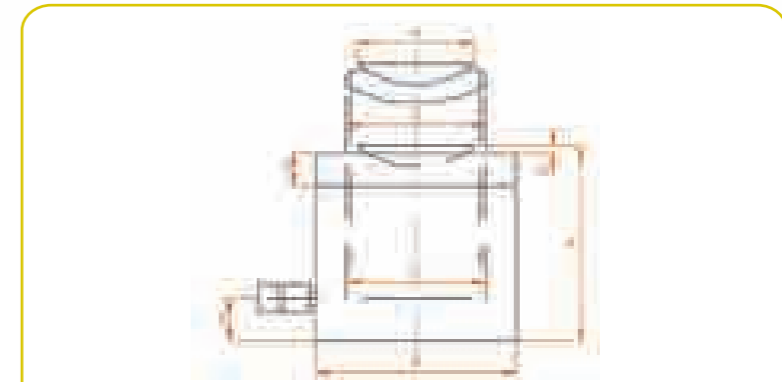

Metric Tons at 700 bar	Stroke (mm)	Order No.	Oil Cap. (cm ³)	A Retracted Height (mm)	B Outside Dia. (mm)	C Piston Rod Dia. (mm)	D Bore Dia. (mm)	E Base to Port (mm)	F Nut Thickness (mm)	G Swivel Cap Protrusion (mm)	H Swivel Cap Dia. (mm)	Weight. (kg)
50	50	RC0552P	355	125	120	95	95	19	21	6	92	11
100	45	RC1002P	597	137	165	130	130	21	31	8	126	22
155	45	RC1552P	905	148	205	160	160	27	38	9	148	39
240	45	RC2402P	1.413	155	255	200	200	28	40	10	157	59
380	45	RC3802P	2.208	178	320	250	250	35	50	11	240	110
620	45	RC6202P	3.618	192	405	320	320	38	60	10	295	193

Locking Collar CYLINDER RL SERIES STEEL

55 -565 Ton
Single- Acting,
Load-Return

Positive mechanical lock to support load.

- Support lifted load for extended periods of time with hydraulic pressure released.
- Visible indicator band alerts when stroke limit is reached; overflow port ("weep hole") stroke limiter prevents piston from being overextended.
- All cylinders feature coated pistons to resist corrosion and abrasion.

ASME B30.1
10,000 PSI



R556L

SWIVEL CAPS - For use with "RL" cylinders
Reduce the effects of off center loading. Tilts up to 5 degrees. Radial grooves on top of cap reduce load slippage. Notch across face of each cap helps keep loads having a protruding or round shaped centered.

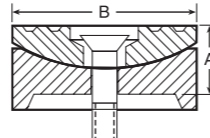

A (mm)	B (mm)	Use with Cyl. No.	Swivel Cap Order No.	Wt. (kg)
25,4	71,4	55-100 ton	420866	0,8
38,1	130,2	150-200 ton	420867	4,8
44,5	149,2	280 ton	420868	6,1
69,9	195,3	355 ton	420869	16,8
79,4	225,4	435 ton	420870	23,6
92,1	250,8	565 ton	420871	35,4

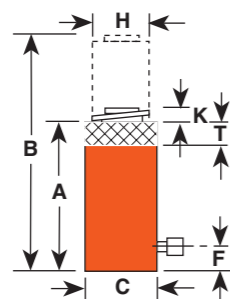

Locking collar feature permits non-hydraulic support of load.

CYLINDERS

CYLINDERS

Cyl. Cap. (tons)	Stroke (mm)	Order No.	Oil Cap. (cm ³)	A Retracted Ht. (mm)	B Extended Ht. (mm)	C Outside Dia. (mm)	F Base to Port (mm)	H Piston Rod Dia. (mm)	K Piston Rod Protrusion (mm)	T Nut Thickness (mm)	Bore Dia. (mm)	Cylinder Effective Area (cm ²)	Metric Tons at 700 bar	Weight (kg)
55	50,8	R552L	362	161,9	212,7	125,4	25,4	95,3	3,2	36,5	95,3	71,2	50,1	15,3
55	152,4	R556L	1.087	263,5	415,9	125,4	25,4	95,3	3,2	36,5	95,3	71,2	50,1	26,3
55	254,0	R5510L	1.811	365,1	619,1	125,4	25,4	95,3	3,2	36,5	95,3	71,2	50,1	36,3
100	50,8	R1002L	677	184,2	235,0	165,1	25,4	130,2	3,2	44,5	130,2	133,1	93,4	30,0
100	152,4	R1006L	2.030	285,8	438,2	165,1	25,4	130,2	3,2	44,5	130,2	133,1	93,4	46,8
100	254,0	R10010L	3.383	387,4	641,4	165,1	25,4	130,2	3,2	44,5	130,2	133,1	93,4	64,5
150	50,8	R1502L	1.007	206,4	257,2	204,8	31,8	158,8	3,2	44,5	158,8	197,9	139,1	53,0
150	152,4	R1506L	3.019	308,0	460,4	204,8	31,8	158,8	3,2	44,5	158,8	197,9	139,1	80,4
200	50,8	R2002L	1.355	241,3	292,1	235,0	41,3	184,2	3,2	50,8	184,2	266,3	187,2	83,1
200	152,4	R2006L	4.062	342,9	495,3	235,0	41,3	184,2	3,2	50,8	184,2	266,3	187,2	117,6
280	50,8	R2802L	1.861	247,7	298,5	276,2	41,3	215,9	3,2	57,2	215,9	366,0	257,3	118,5
280	152,4	R2806L	5.583	349,3	501,7	276,2	41,3	215,9	3,2	57,2	215,9	366,0	257,3	163,0
280	254,0	R28010L	9.305	450,9	704,9	276,2	41,3	215,9	3,2	57,2	215,9	366,0	257,3	208,1
355	50,8	R3552L	2.326	292,1	342,9	298,5	54,0	241,3	3,2	60,3	214,3	457,2	321,4	173,0
355	152,4	R3556L	6.975	393,7	546,1	298,5	54,0	241,3	3,2	60,3	241,3	457,2	321,4	232,5
430	50,8	R4302L	2.841	333,4	384,2	330,2	63,5	266,7	3,2	69,9	266,7	558,5	392,7	252,4
430	152,4	R4306L	8.520	435,0	587,4	330,2	63,5	266,7	3,2	69,9	266,7	558,5	392,7	329,2
430	254,0	R43010L	14.201	536,6	790,6	330,2	63,5	266,7	3,2	69,9	266,7	558,5	392,7	405,9
565	50,8	R5652L	3.710	371,2	422,3	377,8	69,9	304,8	3,2	79,4	304,8	729,5	512,9	368,2
565	152,4	R5656L	11.129	473,1	625,5	377,8	69,9	304,8	3,2	79,4	304,8	729,5	512,9	468,0
565	254,0	R56510L	18.548	574,7	828,7	377,8	69,9	304,8	3,2	79,4	304,8	729,5	512,9	568,0

- **NOTE: Supported loads not to exceed the rated capacity of the cylinders.**
Not intended to support additional dynamic loads, such as those applied by moving vehicles.



Locking Collar CYLINDER RC SERIES

740 & 1220
Single-Acting,
Load Return

Positive mechanical lock to support load.

Single-Acting Locking Collar Cylinders

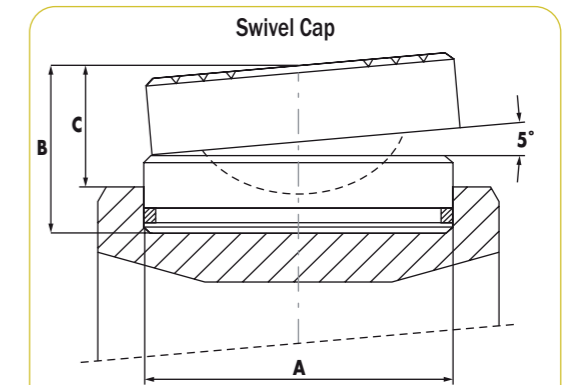
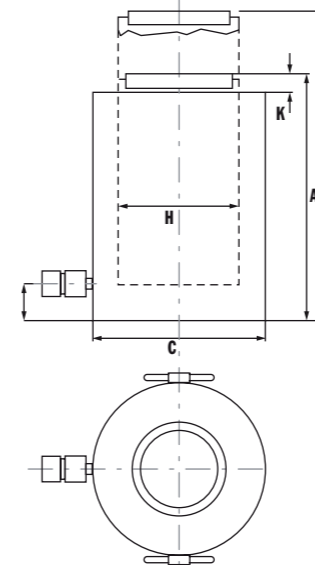

Order No.	Used with cyl.	A mm	B mm	C mm	Product Wt. kg
2000822	RC740*L	200	79	56	19
2000823	RC965*L	249	104	76	40
2000825	RC1220*L	323	175	125	113

Cyl. Cap. (tons)	Stroke (mm)	Order No.	Oil Cap. (mm ³)	A Retracted Height (mm)	B Extended Height (mm)	C Outside Dia. (mm)	F Base to Port (mm)	H Piston Rod Dia. (mm)	K Piston Rod Protrusion (mm)	Bore Dia. (mm)	Cyl. Effective Area (mm ²)	Metric Tons at 700 bar	Product Wt. (kg)
740	50	RC7402L	4.811	395	445	475	90	TR350X6	5	350	962,0	673,5	545
740	150	RC7406L	14.432	495	645	475	90	TR350X6	5	350	962,0	673,5	683
740	250	RC74010L	24.053	595	845	475	90	TR350X6	5	350	962,0	673,5	821
965	50	RC9652L	6.280	455	505	540	100	TR400X6	5	400	1.256,6	879,7	714
965	150	RC9656L	18.849	555	705	540	100	TR400X6	5	400	1.256,6	879,7	990
965	250	RC96510L	31.400	635	885	540	100	TR400X6	5	400	1.256,6	879,7	1.170
1220	50	RC12202L	7.949	443	493	600	110	TR450X6	5	450	1.590,4	1.113,3	969
1220	150	RC12206L	23.856,5	598	748	600	110	TR450X6	5	450	1.590,4	1.113,3	1.310
1220	250	RC122010L	39.741	698	948	600	110	TR450X6	5	450	1.590,4	1.113,3	1.530

Accessories

C SERIES

Mounting accessories

C Series

CYLINDERS

CYLINDERS



Threaded Connector



Cylinder Tons	Part No.	A (mm)	B (mm)	C (in)	D (mm)	E
5	25748	44,5	22,4	3/4-14 NSPM	4,8	12,7
10	25664	41,4	36,6	1 1/4-11 1/2 NSPM	7,9	14,2
25	25654	57,2	54,1	2-11 1/2 NSPM	9,7	16



Piston Clevis



Cylinder Tons	Part No.	A (mm)	B (mm)	C (mm)	D (mm)	E (mm)	F (mm)
5**	350095	44,5	28,7	16	36,6	16	14,2
10 or 15**	350094	65	42,9	22,4	58,7	25,4	25,4
25**	420059	74,7	57,2	31,8	68,3	31,8	38,1

** Can be used with RD106, RD1010 Cylinder.

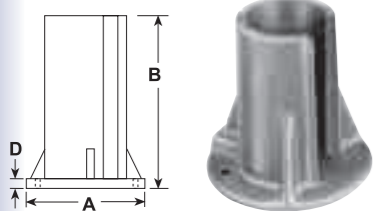

Support Base

Cylinder	Order	A (mm)	B (mm)	C (mm)
10	420062	177,8	127	11,2
25	420063	177,8	127	11,2



Threaded Adapter Plain Adapter

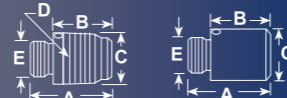

Cylinder Tons	Part No.	A (mm)	B (mm)	C (mm)	D (in)	E
5	202178 (threaded)	41,4	28,7	26,9	3/4-14 NPT	3/4-16UNF-2A
10 or 15	202179 (threaded)	46,0	26,9	41,4	1 1/4-11 1/2-NPT	1-8UNC-2A
25	202180 (threaded)	69,9	47,8	60,5	2-11 1/2-NPT	1 1/2-16UN-2A
10 or 15	350724 (plain)	50,8	31,8	37,6	-	1-8UNC-2A
25	350723 (plain)	54,1	31,8	57,2	-	1 1/2-16UN-2A

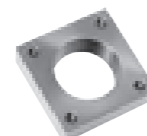

Cylinder Mounting Plate

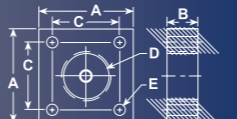

Cylinder Tons	Part No.	A (mm)	B (mm)	C (mm)	D (in)	E (mm)
5	350099	76,2	25,4	54,1	1 1/2-16UN-2B	8,6
10	350100	88,9	25,4	66,8	2 1/4-14UNS-2B	8,6
15	350184	88,9	25,4	66,8	2 3/4-16UN-2B	8,6
25	420064	127	50,8	93	3 5/16-12UN-2B	16,8

Extension Rod

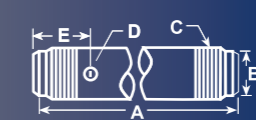

Cylinder Tons	Part No.	A (mm)	B (mm)	C (in)	D (mm)	E (mm)
5	350895	127	22,4	3/4-14 NPT	8,4	50,8
5	38908	254	22,4	3/4-14 NPT	8,4	50,8
5	350896	457,2	22,4	3/4-14 NPT	8,4	50,8
10	350897	127	36,6	1 1/4-11 1/2-NPT	8,4	50,8
10	38909	254	36,6	1 1/4-11 1/2-NPT	8,4	50,8
10	350898	457,2	36,6	1 1/4-11 1/2-NPT	8,4	50,8

Cylinder Base Attachment

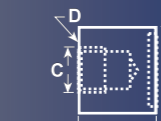

Cylinder Tons	Part No.	A (mm)	B (mm)	C (in)	D (mm/in)
5†	208380	41,4	44,5	3/4-14NPSM	7,1Dia. (No.2) 1/4-20 UNC x3/4" Lg.Socket Head Cap Screws
10†	208381	47,8	63,5	1 1/4-11 1/2-NPSM	8,6 Dia. (No.2) 5/16-18 UNC x1" Lg. Socket Head Cap Screws
25†	208382	60,5	98,6	2-11 1/2-NPSM	13,5 Dia. (No.2) 1/2-13 UNC x 1" Lg. Socket Head Cap Screws

Cylinder Flat Base



Cylinder Tons	Part No.	A (mm)	B (mm)	C (in)	D (mm)
5	25750*	114,3	63,5	3/4-14-NPSM	34
10	32325*	166,6	88,9	1 1/4-11 1/2-NPSM	36,6

Smooth Saddle Serrated Saddle

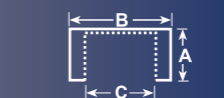

Cylinder Tons	Part No.	A (mm)	B (mm)	C (in)
5	25746* (serrated)	28,7	33,3	3/4-14NPSM
10 or 15	31772* (serrated)	28,7	50,8	1 1/4-11 1/2-NPSM
25	31776* (serrated)	33,3	76,2	2-11 1/2-NPSM
5	351575* (plain)	28,7	33,3	3/4-14-NPSM
10	24016* (plain)	28,7	50,8	1 1/4-11 1/2-NPSM
25	351576* (plain)	33,3	76,2	2-11 1/2-NPSM

Body Clevis†



Cylinder Tons	Part No.	A (mm)	B (mm)	C (mm)	D (mm)	E (mm)	F (mm)
5	350096	52,3	28,7	16	16	14,2	6,4
10	350097	76,2	42,9	22,4	25,4	25,4	6,4
15	350098	77,7	42,9	22,4	25,4	25,4	6,4
25	420061	90,4	57,2	31,8	31,8	38,1	6,4

* Items require threaded adapter (Page 36) when used with "C" series cylinders. They may be used on threaded "CBT" cylinders without the use of an adapter.

† Mounting screws are included.

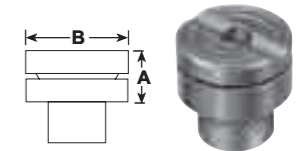

Swivel Cap

Cylinder Tons	Part No.	A (mm)	B (mm)
10 or 15	350144	22,4	36,5
25	350145	28,7	54
55 or 75	350376	31,8	71,4
100	351574	48,5	88,1

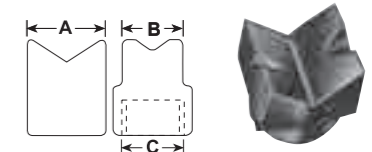

Cylinder Tons	Part No.	A (mm)	B (mm)	C (in)
5	25388*	35,1	26,9	3/4-14-NPSM
10	25395*	54,1	54,1	1 1/4-11 1/2-NPSM

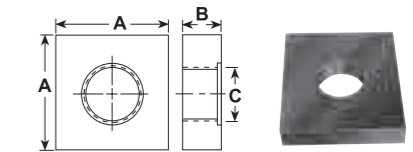

Plunger Base

Cylinder Tons	Part No.	A (mm)	B (mm)	C (in)
25	25652	152,4	31,8	2-11 1/2-NPSM

Accessories

Swivel Caps Center Hole Accessories



SWIVEL CAPS FOR "RSS",						SWIVEL CAPS FOR "RD" CYLINDERS					
Use with	Swivel Cap	Weight	A	B	C	Cylinder	Swivel Cap	Weight	A	B	C
RSS101	350320	0,2	25,4	36,5	36,5	10	350144	0,4	22,2	36,5	21,8
RSS202	350321	0,6	34,9	54	54	25	350145	0,6	28,6	54	36,5
RSS302	350322	0,7	34,9	63,5	54	55	351325	1,9	61,9	63,5	39,3
RSS502	350331	1,2	36,5	82,6	54	100	351324	5,1	75,0	95,3	67,5
RSS1002	350332	3,0	46	111,1	85,7	150	351334	5,8	66,7	111,1	77,8
Tonnage		"RA" Cylinders									
55	350376	0,9	31,8	71,4	71,4						
100	350984	2,5	49,2	95,3	79,4						

For use with "RC" cylinders			SWIVEL CAPS Reduce the effects of off center loading. Tilts up to 5 degrees. Radial grooves on top of cap reduce load slippage.			For use with "RL" cylinders			
Use with Cyl. No.	Swivel Cap Order No.	Weight (kg)	A (mm)	B (mm)	Use with Cyl. No.	Swivel Cap Order No.	Weight (kg)	A (mm)	B (mm)
150-200 ton	420867	4,0	38,1	130,2	55-100 ton	420866	0,8	25,4	71,4
280 ton	420868	6,1	44,5	149,2	150-200 ton	420867	4,8	38,1	130,2
355 ton	420869	16,8	69,9	195,3	280 ton	420868	6,1	44,5	149,2
435 ton	420870	23,6	79,4	225,4	355 ton	420869	16,8	69,9	195,3
565 ton	420871	35,4	92,1	250,8	435 ton	420870	23,6	79,4	225,4
					565 ton	420871	35,4	92,1	250,8

Reduce the effects of off center loading. Tilts up to 5 degrees. Radial grooves on top of cap reduce load slippage. Notch across face of each cap helps keep loads having a protruding or round shaped centered.

"CENTER-HOLE" CYLINDER ACCESSORIES				
To use with Cyl. No.	RT172, RH203	RT302, RH302, RH303, RH306	RT503, RH503, RH603, RH605, RH606	RT1004
Order Set No.	RHA20	RHA30	RHA50	RHA100
1 Speed Crank	1 24814	27198	29595	303785
2 Speed Nut	2 302482	302483	33439	34136
3 Adjusting Screw	3 32118	34758	32698	32699
4 Threaded Insert	4	Order threaded insert for RH series cylinders with the accessory set. (See page 36/37) Threaded insert supplied with RT series cylinders.		
5 Pushing Adapter	5 201923	34510	34755	-
6 Pushing Adapter	6 201454	34511	34756	-
7 Jack Screw	7 24813	25931	32701	32702
8 Screw Cap	8 28228	28229	28230	-

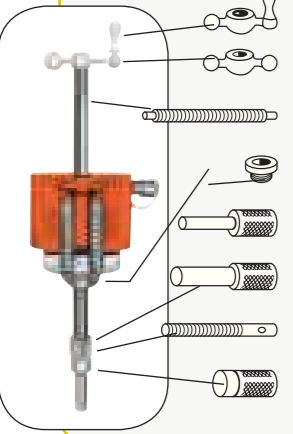

Accessories

Seal Kits

Cylinder Order No.	Seal Kit*	Viton Seal Kit
C51C	300404	300210
C53C	300404	300210
C55C	300404	300210
C57C	300404	300210
C59C	300404	300210
C101C	300116	300211
C102C	300116	300211
C104C	300116	300211
C106C	300116	300211
C108C	300116	300211
C1010C	300116	300211
C1012C	300116	300211
C1014C	300116	300211
C1016C	300116	300211
C151C	300453	300471
C152C	300453	300471
C154C	300453	300471
C156C	300453	300471
C158C	300453	300471
C1510C	300453	300471
C1512C	300453	300471
C1514C	300453	300471
C1516C	300453	300471
C251C	300147	300213
C252C	300147	300213
C254C	300147	300213
C256C	300147	300213
C258C	300147	300213
C2510C	300147	300213
C2512C	300147	300213
C2514C	300147	300213
C552C	300114	300215
C554C	300114	300215
C556C	300114	300215
C5510C	300114	300215
C5513C	300114	300215
C756C	300647	300846
C7513C	300647	300846
C1002C	300112	300216
C1006C	300112	300216
C10010C	300112	300216
C55CBT	300404	300210
C106CBT	300116	300211
C1010CBT	300116	300211
C256CBT	300147	300213
C2514CBT	300147	300213
R1502C	300676	-
R1506C	300676	-
R15010C	300676	-
R2002C	300677	-
R2006C	300677	-

Cylinder Order No.	Seal Kit*	Viton Seal Kit
R20010C	300677	-
R2802C	300678	-
R2806C	300678	-
R28010C	300678	-
R3552C	300679	-
R3556C	300679	-
R35510C	300679	-
R4302C	300680	-
R4306C	300680	-
R43010C	300680	-
R5652C	300681	-
R5656C	300681	-
R56510C	300681	-
R1002D	300928	-
R1006D	300928	-
R10010D	300928	-
R1502D	300929	-
R1506D	300929	-
R15010D	300929	-
R2002D	300930	-
R2006D	300930	-
R20010D	300930	-
R2802D	300931	-
R2806D	300931	-
R28010D	300931	-
R3552D	300932	-
R3556D	300932	-
R35510D	300932	-
R4302D	300933	-
R4306D	300933	-
R43010D	300933	-
R5652D	300934	-
R5656D	300934	-
R56510D	300934	-
R552L	300674	-
R556L	300674	-
R5510L	300674	-
R1002L	300675	-
R1006L	300675	-
R10010L	300675	-
R1502L	300676	-
R1506L	300676	-
R15010L	300676	-
R2002L	300677	-
R2006L	300677	-
R20010L	300677	-
R2802L	300678	-
R2806L	300678	-
R28010L	300678	-
R3552L	300679	-
R3556L	300679	-

Cylinder Order No.	Seal Kit*	Viton Seal Kit
R35510L	300679	-
R4302L	300680	-
R4306L	300680	-
R43010L	300680	-
R5652L	300681	-
R5656L	300681	-
R56510L	300681	-
RA202	300631	-
RA204	300631	-
RA206	300631	-
RA302	300632	-
RA304	300632	-
RA306	300632	-
RA552	300391	-
RA554	300391	-
RA556	300391	-
RA5510	300391	-
RA1002	300444	-
RA1006	300444	-
RA556L	300395	-
RA1006L	300396	-
RD106	300017	-
RD1010	300017	-
RD256	300118	-
RD2514	300118	-
RD556	300005	-
RD5513	300005	-
RD5518	300005	-
RD8013	300410	-
RD1006	300006	-
RD10013	300006	-
RD10020	300006	-
RD1506	300007	-
RD15013	300007	-
RD15018	300007	-
RD2006	300008	-
RD20013	300008	-
RD3006	300466	-
RD30013	300466	-
RD4006	300467	-
RD40013	300467	-
RD5006	300468	-
RD50013	300468	-
RH102	300071	300221
RH108	300071	300221
RH120	300657	-

Cylinder Order No.	Seal Kit*	Viton Seal Kit
RH121	300576	-
RH121T	300576	-
RH123	300576	-
RH202	300615	-
RH203	300069	300222
RH206	300615	-
RH302	300037	300223
RH306	300037	300223
RH503	300059	300225
RH603	300477	300476
RH606	300477	300476
RH1003	300485	300585
RH303	300077	300224
RH306D	300822	300224
RH3010	300625	-
RH605	300269	300226
RH6010	300626	-
RH1001	300927	-
RH1006	300295	300227
RH10010	300629	-
RH1505	300154	300228
RH1508	300583	-
RH2008	300582	-
RHA306	300867	300868
RHA604D	300269	300226
RLS50	300454	-
RLS100	300455	-
RLS200	300456	-
RLS300	300457	-
RLS500S	300458	-
RLS750S	300459	-
RLS1000S	300460	-
RLS1500S	300461	-
RP25	300628	-
RP55	300627	-
RSS101	300010	-
RSS202	300011	-
RSS302	300297	-
RSS502	300292	-
RSS1002	300293	-
RSS2503	-	-
RSS1002D	300578	-
RT172	300358	-
RT302	300359	-
RT503	300360	-
RT1004	300024	-

* Nitrile seals come standard on all cylinders.

Accessories

Cribbing Blocks

Convert Power Team "Shorty" cylinders to mechanical cribbing devices; more stable than timber or other awkward, makeshift methods. Ideal for lifting applications such as structure moving. Reduce cribbing time dramatically. In effect, increases the stroke of the cylinder; stacking pads act as cylinder extensions:

1. Extend cylinder and insert lower supporting ring.
2. Retract cylinder, insert a stacking pad.
3. Extend cylinder again; pad increases cylinder stroke.
4. Repeat process until all rings and pads are used.

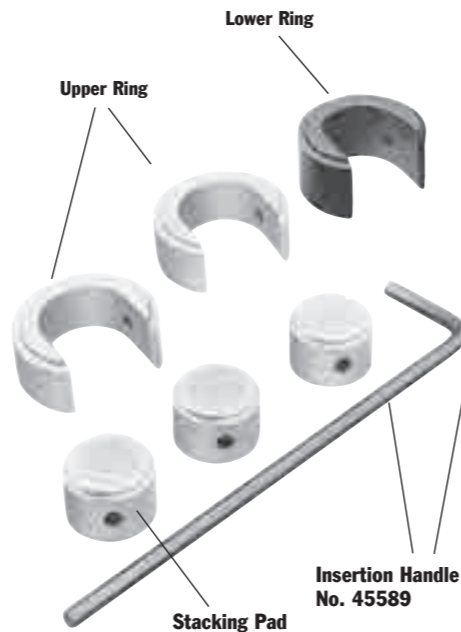

Each cribbing block set includes rings, pads and insertion handle.

- No. CB30 – Cribbing block set for use with No. RSS302; 30 ton cylinder.
- No. CB50 – Cribbing block set for use with No. RSS502; 50 ton cylinder.
- No. CB100 – Cribbing block set for use with No. RSS1002; 100 ton cylinder.
- No. 45589 – Insertion handle is used for inserting rings and pads.

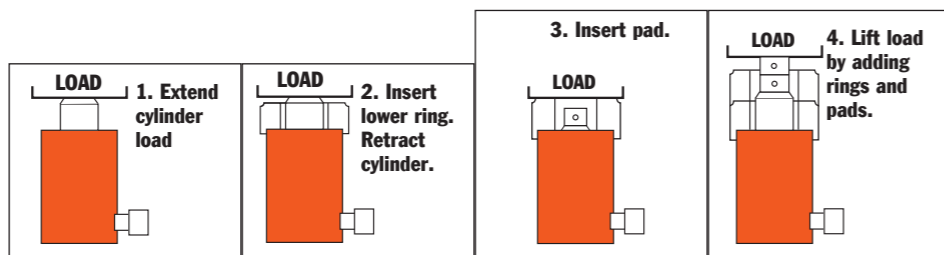

FOR USE WITH ORDER NUMBER	30 TON CYLINDER NO. RSS302 30 TON SET NO. CB30			50 TON CYLINDER NO. RSS502 50 TON SET NO. CB50			100 TON CYLINDER NO. RSS1002 100 TON SET NO. CB100		
	Lower Ring	Upper Ring	Stacking Pad	Lower Ring	Upper Ring	Stacking Pad	Lower Ring	Upper Ring	Stacking Pad
No. included in set	1	2	3	1	2	3	1	2	3
Outside Diameter (mm)	114,3	114,3	69,9	139,7	139,7	85,7	187,7	187,7	120,7
Inside Diameter (mm)	71,4	71,4	—	87,7	87,7	—	122,2	122,2	—
Height, each (mm)	57,9	45,6	45,2	56,4	43,7	42,8	54	44,5	43,7
Total stacked height of rings in Set (mm)	138,1			131,7			174,6		
Weight of Set (kg)	9,1			12,7			29		

Each set includes one Insertion Handle No. 45589 - 1/2" Hex. x 18" Long, 4" Bend

Accessories

Cylinder



CYLINDER LIFTING HANDLE

No. 420655OR9 – Lifting handle for "C" series, 25 ton cylinders.

No. 421312OR9 – Lifting handle for RH302, RH303, RH306 and RH306D, cylinders.

No. 252215 – Lifting handle RHA306, 30 ton cylinder.

No. 420496BK2 – Lifting handle RA552 and RA554, 55 ton cylinders.

No. 420498BK2 – Lifting handle RA1002, 100 ton cylinder.

ALUMINUM CYLINDER BASE

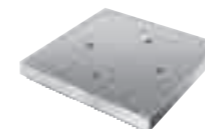

Aluminum Cylinder Base – For use when an enlarged cylinder base is needed or advantageous. Attaches to bottom of RA556, RA556L and RA5510 with four 3/8"-16 screws (included). Serrated base for extra stability.

No. 208406 – Aluminum cylinder base, 317 cm². For use with RA556, RA556L and RA5510 cylinders.



Quick-Change Inserts

HEAD INSERTS FOR RH SERIES CYLINDERS

For Use With:	Threaded Insert Order No.
RH102, RH108	28632 3/4"-16
RH203	28612 1"-8
RH302, RH306	38904 1 1/4"-7
RH303	28644 1 1/4"-7
RH503	38855 1 3/8"-5 1/2
RH603, RH605	34251
RH606	1 3/8"-5 1/2

"QUICK CHANGE" HEAD INSERTS FOR RT SERIES CYLINDERS

For Use With:	Threaded Order No.*	Plain Order No.	
RT172	21669	21714	Switch from a tapped hole to a plain hole quickly with these cylinder head inserts. They are held in place with a socket screw. Plain hole permits use of a speed nut for readjusting cylinder after extension.
RT302	21873	21872	
RT503	22274	22275	
RT1004	24197	24196	

* Provided with cylinder

PUMPS

HIGH PERFORMANCE PUMPS



Page ...44-47 PUMP SELECTION 	Page PA60...68 Air Hydraulic 	Page PE55...94 Vanguard® Electric Hydraulic 
Page VALVES...48-57 	Page PA50...70 Air Hydraulic 	Page PE60...96 Air Hydraulic 
Page P SERIES...58-60 Hand Pumps 	Page PA17...72 Air Hydraulic 	Page PQ60...98 Quiet Electric Hydraulic 
Page RPS SERIES...61 Cylinder and Pump Sets 	Page PA46/55...74 Air Hydraulic 	Page PQ120...100 Quiet Electric Hydraulic 
Page PA6...62-63 Air Hydraulic 	Page PUA, PMA...76-79 Air Operated Pump 	Page PE400...102 Electric Hydraulic 
Page PA6D...64-65 Air Hydraulic 	Page PE10...80 Electric Battery 	Page PE-NUT...104 Electric Hydraulic 
Page PA9...66 Air Hydraulic 	Page PE17...82 Electric Hydraulic 	Page PG120...105 Gasoline Driven 
	Page PE18...84 Vanguard Jr.® Electric Hydraulic 	Page PG30/55...106 Gasoline Driven 
	Page PE21...86 Electric Hydraulic 	Page PG120-PG400...108 Gasoline Driven 
	Page PE2...88 Electric Hydraulic 	Page INTENSIFIER...110 
	Page PE30...90 Vanguard® Electric Hydraulic 	Page POWER TEAM PUSHES BRIDGE CONSTRUCTION...111 
	Page PE46...92 Electric Hydraulic 	Page ASSEMBLE TO ORDER...112 Page PUMP ACCESSORIES...116 

Pump Selection

HIGH PERFORMANCE

Choosing the Right Pump

PUMPS



- Step 1** – Select the hydraulic cylinder that best suits the application. See pages 6-8.
- Step 2** – Select the series of hydraulic pump with adequate oil output and reservoir capacity to power cylinder. See page 44-50. Check speed/selection chart on page 6.
- Step 3** – Select pump within series with the valve option that is best suited to the cylinder and application. See pages 36-41.

CONSIDERATIONS:

What maximum system operating pressure (bar) is required?

What volume of oil delivery is required? (For manual pumps, cm³ of oil per handle stroke; for powered pumps, l./min. of oil).

Is a single- or 2-speed pump required? (2-speed pumps deliver high oil volume at low pressure for rapid cylinder piston advance, then shift to the high pressure, low volume stage under load).

What is the preferred source of power?

- Manual (hand or foot operated). Provides portability, can be used where electricity or shop air are not available.
- Air/Hydraulic. Uses shop air or a portable air compressor.
- Electric /Hydraulic. What voltage is available? Is a battery operated pump preferred?
- Gasoline Engine/Hydraulic. Powers high-output pumps at remote job sites where air or electricity are unavailable.

Is portability of the pump a factor to consider?

Will the pump be used intermittently, or will it need to provide high-cycle operation? Does the application require that the pump be capable of starting under load?

Is fluid heat build-up a factor in your application? High cycle applications may require a larger capacity oil reservoir for cooling. Also, if you are using large displacement

cylinders, the reservoir capacity must be sufficient to fully extend the piston of the cylinder.

Will the application require large displacement or multiple cylinders? Reservoir size and pump output levels will be factors to consider.

Does the working environment require a pump having a low operating noise (dBA) level?

Must the pump operate in a spark-free environment?

MANUALLY-OPERATED HYDRAULIC PUMPS:

P12, P23, P55 – These single-speed pumps are for use with single-acting cylinders. See page 58.

P19, P59, P59F, P157, P159, P300, P460 – These 2-speed pumps are used with single-acting cylinders. The 2-speed feature provides high oil volume for fast cylinder piston approach to the work; pump automatically shifts to the high pressure stage. This reduces the number of pump handle strokes required. See pages 59-60.

P157D, P159D, P300D, P460D – These 2-speed pumps are used with double-acting cylinders. See page 60.

AIR/HYDRAULIC PUMPS

Used where air is the preferred energy source or where electricity is not available. Ideal for use in petrochemical, mines or other inflammable or explosive environments.

PA6 Series – These single-speed pumps drive single- or double-acting cylinders. See pages 62-65.

PA9 Series – These new single-speed pumps drive single-acting cylinders and are ideal for powering portable hydraulic tools. See pages 66-67.

PA50 Series – These single-speed pumps drive single- or double-acting low pressure (225 bar) cylinders. See pages 70-71.

PA60 – This 2-speed pump is equipped with a manifold to operate multiple cylinders, and provides a 7,6 liter reservoir capacity. See pages 68-69.

PA64 – Similar to PA60, this 2-speed pump drives single- or double-acting cylinders. See pages 68-70.

PA172 and PA174 – These “economy” 2-speed pumps drive single- or double-acting cylinders, depending on the model chosen. Provide a low weight to output ratio. See pages 72-73.

PA462 and PA464 Series – These 2-speed pumps drive single or double-acting cylinders, depending on the model selected. They offer high speed cylinder piston advance. See pages 74-75.

PA554 – This 2-speed pump drives single- or double-acting cylinders, delivering a high volume of oil. See pages 72-74.

ELECTRIC/HYDRAULIC PUMPS

All of the following pumps are 2-speed models, and can be used to drive single- or double-acting cylinders.

“Quarter Horse” Series – As their name implies, these pumps feature a 0,18Kw (1/4 hp) electric motor. A battery-powered version is available. Having a low noise level and weighing just 9 kg, they are ideal for powering portable hydraulic spreaders, nut splitters, pipe flange spreaders and other tools. See pages 80-81.

PE17 Series – CSA rated for intermittent duty, these feature a 0,37Kw (1/2 hp), single phase induction motor with a low noise level (67-81 dBA). Smaller generators and low amperage circuits can be used as a power source. See pages 82-83.

PE46 Series – Powered by a 1,1Kw (1 1/2 hp), single phase induction motor, operate at a moderate noise level of 77-81 dBA. CSA rated for intermittent duty. See pages 92-93.

PE18 Series – CSA rated for intermittent duty, these feature a 0,37Kw (1/2 hp), single phase universal motor with a noise level of 85-90 dBA. Provide high performance at a low price. Has low amperage draw. See pages 84-85.

PE30 Series – Equipped with a 0,75Kw (1 hp), single phase permanent magnet motor, have a noise level of only 82-87 dBA. CSA rated for intermittent duty, and require a relatively low voltage; ideal for use in general construction applications. Roll cage/handle protects the motor and controls. See pages 90-91.

PE55 and PED25 Series – The famous Vanguard® pumps have been continually upgraded for 40 years; some of the originals are still in service! Equipped with a 0,83Kw (1 1/8 hp), single phase universal motor, have a high noise level (90-95 dBA). Offer the best weight to performance ratio of any Power Team electric/hydraulic pump. CSA rated for intermittent duty. The PED25 versions are “dual flow” pumps which deliver the same low and high pressures to both valves, and have a noise level of 80-85 dBA. They have a 1,1Kw (1 1/2 hp) induction motor.

See pages 88-89, 94-95.



PUMPS

Pump Selection

HIGH PERFORMANCE

Choosing the Right Pump



PE60 Series – The Vanguard® Supreme® pumps provide trouble-free service in the most severe working environments. Powered by a 0,82Kw (1¹/₈ hp), single phase motor, has a moderate noise level of 80-85 dBA. Start well under load even at the reduced voltages encountered on construction sites. High-output pumps, ideal for use with post-tensioning/pre-stressing jacks and other high-pressure hydraulic tools. See pages 96-97.

“Custom-built” pumps – Power Team offers you “assemble to order” electric/hydraulic pumps to suit unique applications. You can choose from pre-engineered, off the-shelf components to customize your pump. See pages 112-115.

PE21 Series – Ideal for heavy-duty, extended-cycle applications. Powered by a 0,75Kw (1 hp), single phase motor, pump operates a very low noise level of 70 dBA. Pump automatically shuts down in the event of a power failure. CSA rated for intermittent duty. See pages 86-87. “Quiet” Pumps. Our PQ60 and PQ120 series operate at a very low noise level of between 73-78 dBA. The PQ60 has a 1,5Kw (2 hp) (single phase) motor; the PQ120 has a 2,2Kw (3 hp) (3-phase) motor. These pumps are designed for heavy-duty, extended cycle operations. CSA rated for intermittent duty. See page 86.

PE400 Series – High-flow units deliver a large volume of high pressure oil for heavy construction and maintenance operations employing high tonnage cylinders. The PE400 is powered by a 7,5Kw (10 hp), 3-phase motor. Low noise rating of 73-80 dBA. See pages 102-103.

GASOLINE-DRIVEN HYDRAULIC PUMPS

These two-speed pumps are ideal for use in remote applications, such as construction sites. May be used with single- or double-acting cylinders.

PG30 Series – Powered by a 2-cycle, 1,5Kw (2 hp) Tecumseh engine, these have an integral, protective “roll cage” and adequate reservoir capacity for cylinders up to 100 tons capacity or more. Readily portable; popular in the railroad, rescue and construction markets. See pages 106-107.

PG55 Series – With a 4-cycle, 3Kw (4 hp) Briggs & Stratton engine, this pump is based on our popular Vanguard® Series. It has a generous five gallon reservoir capacity. See pages 106-107.

PG120 Series – Powered by a 4-cycle, 4,1Kw (5.5 hp) Honda engine. Has a 19 liter reservoir; capable of handling multiple-cylinder lifting tasks. Ideal for the structure moving, pier setting, bridge lifting and concrete contracting industries. See pages 108-109.

PG4004 – Featuring a 4-cycle, 13,5Kw (18 hp) Briggs & Stratton engine, this unit has a big 76 liter reservoir. Rugged steel “roll cage” has a hook on top and swivel casters for ease of mobility. Popular for concrete stressing applications. See pages 108-109.

HYDRAULIC INTENSIFIER

HB Series – Turns low pressure hydraulic pumps into high pressure power sources to operate single-acting or double-acting cylinders and tools such as crimpers, spreaders, cutters, etc. Compact and portable for use inside a utility vehicle aerial bucket or stowing in a vehicle. See page 110.



PUMP SELECTION

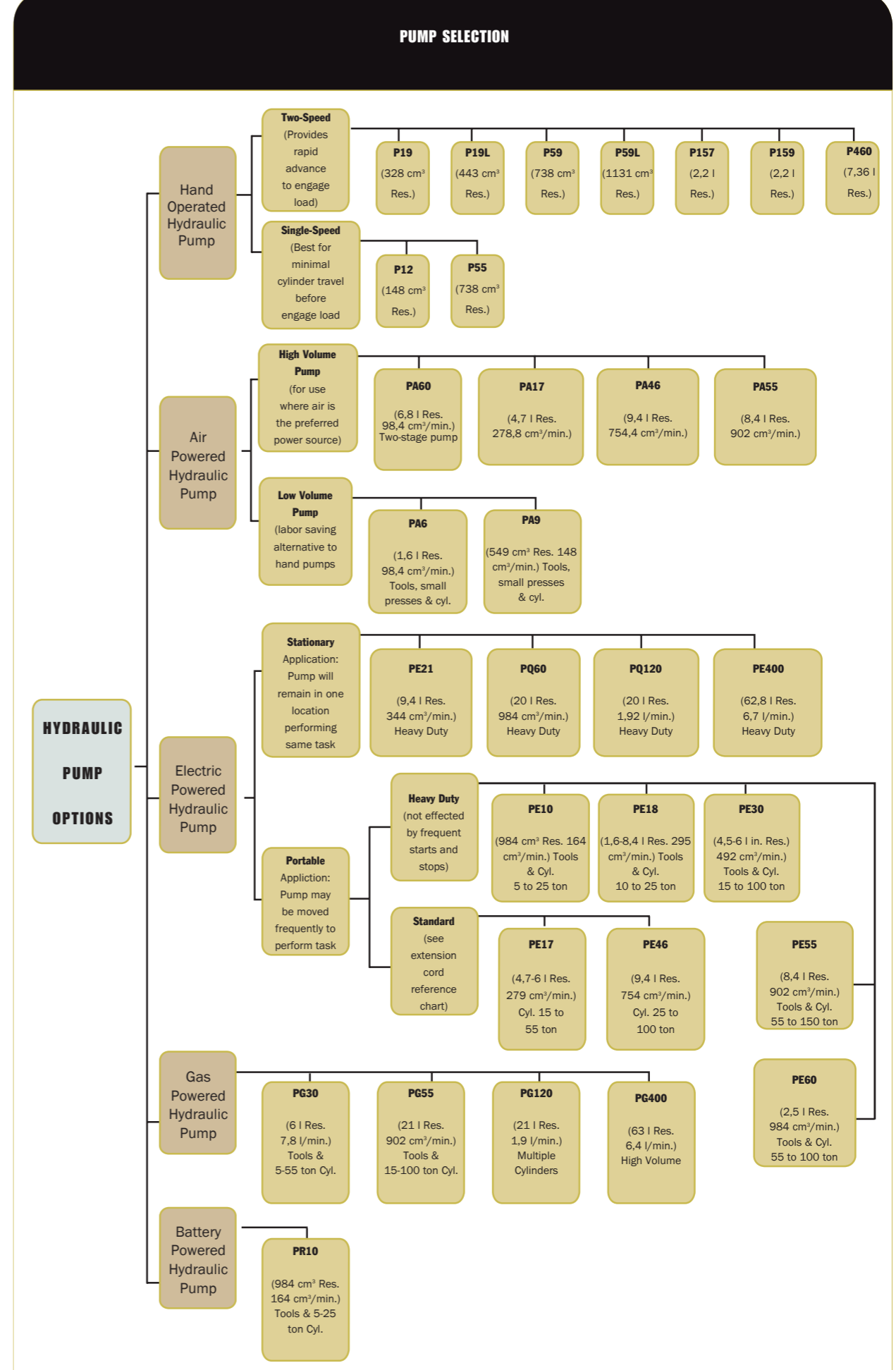

Valve Selection

Choosing the Right Valve

- Step 1 -** Select the hydraulic cylinder that best suits the application. See pages 6-8.
- Step 2 -** Select the series of hydraulic pump with adequate oil output and reservoir capacity to power cylinder. See pages 42-45. Check speed chart on page 6.
- Step 3 -** Select pump within series with the valve option that best matches cylinder, pump and application. See pages 122-127.

CONSIDERATIONS:

- Will the valve be used with single or double-acting cylinders?
- Will the valve be mounted on the pump, away from the pump or directly into the hydraulic lines?



- Will the valve be manually operated or is remote control preferred?
- Is independent control of multiple cylinders, or hydraulic tools preferred?
- What directional control and pressure control valve functions are needed for the application?

Basic valve types include manually operated, air or solenoid operated and pilot operated. Special application valves for pre-stressing and post-tensioning are also offered. Consult selection chart on page 50 for listings of all Power Team valves.

DIRECTIONAL CONTROL VALVES



2-WAY, 2-POSITION

(FOR CONTROL OF SINGLE-ACTING CYLINDERS):

POSITION 1	CENTER POSITION	POSITION 2
 <p>Oil goes from pump to cylinder; pressure is held from valve to cylinder when pump is shut off.</p>	None	 <p>Oil goes from cylinder to pump; pressure is released to reservoir when motor is turned off.</p>



3-WAY, 2-POSITION

(FOR CONTROL OF SINGLE-ACTING CYLINDERS)

POSITION 1	CENTER POSITION	POSITION 2
 <p>Oil goes from pump to cylinder and holds when pump is shut off. Return line to reservoir is blocked.</p>	None	 <p>Cylinder retracts, oil returns to reservoir.</p>

3-WAY, 3-POSITION

(FOR CONTROL OF SINGLE-ACTING CYLINDERS)

POSITION 1	CENTER POSITION	POSITION 2
 <p>Oil goes from pump to cylinder and holds when pump is shut off. Return line to reservoir is blocked.</p>	 <p>Cylinder pressure is held; pump can remain running and oil returns to reservoir.</p>	 <p>All oil is open to reservoir through return line.</p>

IN-LINE HYDRAULIC VALVES

Load Lowering Valve – Provides precision metering for controlled return of the cylinder piston.

Sequence Valve – Used when a cylinder in a multiple cylinder application must advance before any other.

Pressure Reducing Valve – Permits independent pressure control to two or more clamping systems operated by a single power source.

Shut-off Valve – For fine metering of hydraulic oil. Several may be used to control multiple single-acting cylinders.

Check Valve – Permits flow of hydraulic oil in one direction only.

Pressure Relief Valve – Used at remote locations in a hydraulic circuit where maximum pressure requirements are less than the setting of the basic overload valve in the pump. Protects a hydraulic system against over pressurization.



Metering Valve – Restricts surges by restricting flow to a certain level; when flow subsides, valve reopens automatically. For systems using large cylinders or extended lengths of hose.

Pressure Regulator Valve – Permits external adjustment of operating pressures at various values below the internal relief valve setting of the pump.

DIRECTIONAL CONTROL VALVES



4-WAY, 2-POSITION

(FOR CONTROL OF SINGLE OR DOUBLE-ACTING CYLINDERS):



POSITION 1	CENTER POSITION	POSITION 2
 <p>Oil goes to the "extend" side of the cylinder. The oil from the "retract" side returns to reservoir. Cylinder holds with pump shut off.</p>	None	 <p>Oil goes to the "retract" side of the cylinder, oil from the "extend" side returns to reservoir.</p>

4-WAY, 3-POSITION

(FOR CONTROL OF DOUBLE-ACTING CYLINDERS)

POSITION 1	CENTER POSITION	POSITION 2
 <p>Oil goes to the "extend" side of the cylinder, oil from the "retract" side returns to reservoir. Cylinder holds with pump shut off.</p>	 <p>Holds pressure even if pump is running. Oil from pump goes through valve, back to reservoir.</p>	 <p>Oil goes to "retract" side of cylinder. Oil from "extend" side returns to the reservoir.</p>

TYPICAL CENTERS

TANDEM CENTER	CLOSED CENTER	OPEN CENTER
 <p>Cylinder ports are blocked, oil from pump goes to reservoir. Used when pump remains running. Example: gasoline-driven pumps.</p>	 <p>Generally used when running multiple valves in series from one pump.</p>	 <p>Open Center used when holding is not a requirement, as when running two separate hydraulic tools such as cutters and crimpers.</p>

Valves

SELECTION INFORMATION

Pump Mounted Valves

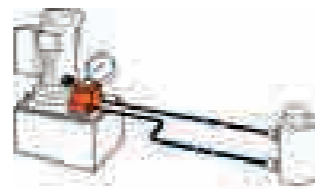

PUMP MOUNTED VALVES

Order No.	Page No.	*Cylinder Application	Operation	Valve Type	Volt	Advance/Return	Advance/Hold Return	Posi-Check Feature
9500	53	S.A. & D.A.	Manual	4-way, 3 Pos. Tandem Center	—	no	yes	no
9501	53	S.A. & D.A.	Manual	4-way, 3 Pos. Closed Center	—	no	yes	no
9502	52	S.A.	Manual	3-way, 3 Pos. Closed Ctr.	—	no	yes	yes
9504	51	S.A. & D.A.	Manual	3/4-way, 2 Pos.	—	yes	yes	no
9506	53	D.A.	Manual	4-way, 3 Pos. Tandem Center	—	no	yes	yes
9507	53	D.A.	Manual	4-way, 3 Pos. Closed Center	—	no	yes	yes
9511	53	S.A. & D.A.	Manual	4-way, 3 Pos. Open Center	—	yes	yes	no
9512	56	D.A.	Solenoid	4-way, 3 Pos. Tandem Center	24	no	yes	yes
9513	56	D.A.	Solenoid	4-way, 3 Pos. Tandem Center	115	no	yes	yes
9516	56	D.A.	Solenoid	4-way, 3 Pos. Tandem Center	12DC	no	yes	yes
9517	51	S.A.	Manual	2-way, 2 Pos.	—	no	yes	no
9519	56	D.A.	Solenoid	4-way, 3 Pos. Tandem Center	230	no	yes	yes
9520	52	S.A.	Manual	4-way, 3 Pos. Tandem Center	—	no	yes	yes
9522	56	D.A.	Solenoid	4-way, 3 Pos. Open Center	230	yes	no	no
9523	56	S.A.	Pilot Operated Solenoid	3-way, 2 Pos.	230	yes	no	no
9552	55	S.A. & D.A.	Solenoid	3/4-way, 2 Pos.	230	yes	no	no
9553	56	S.A.	Pilot Operated Solenoid	3-way, 2 Pos.	24	yes	no	no
9569	56	S.A.	Solenoid	3-way, 2 Pos.	24	no	yes	no
9570	56	S.A.	Solenoid	3-way, 2 Pos.	230	no	yes	no
9572	56	S.A. & D.A.	Solenoid	3/4-way, 2 Pos.	24	yes	no	no
9576	52	S.A.	Manual	3-way, 3 Pos. Metering Tandem Ctr.	—	no	yes	no
9579	55	S.A.	Solenoid	3-way, 2 Pos.	115	no	yes	no
9582	51	S.A.	Manual	3-way, 2 Pos.	—	no	yes	no
9584	51	S.A.	Manual	3-way, 2 Pos.	—	no	yes	no
9589	56	S.A.	Pilot Operated Solenoid	3-way, 2 Pos.	115	yes	no	no
9590	56	D.A.	Solenoid	4-way, 3 Pos. Open Center	115	yes	no	no
9592	55	S.A. & D.A.	Solenoid	3/4-way, 2 Pos.	115	yes	no	no
9594	55	S.A. & D.A.	Air	3/4-way, 2 Pos.	—	no	yes	yes
9599	54	S.A.	Pilot Operated Solenoid	3-way, 3 Pos. Tandem Center	24	no	yes	yes
9605	54	S.A.	Pilot Operated Solenoid	3-way, 3 Pos. Tandem Center	115	no	yes	yes
9609	54	S.A.	Manual	3-way, 3 Pos. Tandem Center	—	no	yes	no
9610	51	S.A.	Auto Pilot Operated	3-way, 2 Pos.	—	yes	no	no
9610A	51	S.A.	Manual	2/3-way, 2 Pos.	—	no	yes	no
9615	56	D.A.	Solenoid	4-way, 3 Pos. Open Center	24	yes	no	no
9628	57	S.A. & D.A.	Manual	Post Tensioning	—	special	no	no
9632	57	S.A. & D.A.	Manual	Post Tensioning	—	special	no	no

* "S.A." represents single-acting cylinders, "D.A." represents double-acting cylinders



Valves

HYDRAULIC PUMP MOUNTED

Manual and Pilot Operated

700 bar, 3/8" ports, 19 l/min max flow rate.

3-WAY/2-POSITION MANUAL VALVES

Applications – Single-acting cylinders.

Actuation – Lever operated.

Functions – Cylinder piston "advance", "hold" and "return".

Used on these pumps – P460, PE17, PE21, PE30, PE46, PE55, PE84, PE90, and PE120 series.

No. 9582 – 3-way/2-position manual valve. Wt. 1,13 kg.

No. 9584 – Same as 9582, but has "flipper" control. Wt., 0,8 kg.

3-WAY/2-POSITION, PILOT OPERATED AUTOMATIC VALVE

Application – Single-acting cylinders. Actuation: Pilot oil.

Functions – When pump is started, pilot oil automatically closes valve and directs oil to cylinder; when pump is stopped, valve automatically opens and oil returns to reservoir.

Used on these pumps – Furnished with pilot lines and adapters for PA55, PA90, PE30, PE55, PE90 and PE120 series.

No. 9610 – 3-way/2-position pilot operated automatic valve. Wt., 1,9 kg.

2/3-WAY/2-POSITION MANUAL/PILOT OPERATED AUTOMATIC VALVE

Application – Manual operation for load lifting and holding with single-acting cylinders; automatic "dump" for operating hydraulic tools.

Actuation – Flipper lever/pilot oil.

Functions – With lever in closed position, valve will hold the load. When lever is "open", valve functions as a true automatic "dump" valve.

Used on these pumps – Furnished with pilot lines and adapters for PA55, PA90, PE30, PE55, PE90 and PE120 series. For application on other pumps, consult factory.

No. 9610A – 2/3-way/2-position manual/pilot operated automatic valve.

Wt., 2 kg.

2-WAY/2-POSITION MANUAL VALVE

Application – Single-acting cylinders.

Actuation – Flipper lever operated.

Functions – Cylinder piston "advance", "hold" and "retract".

Used on these pumps – PE172, PA172 and PE84 series.

No. 9517 – 2-way/2-position manual valve. Wt., 1,45 kg.

3/4-WAY/2-POSITION MANUAL VALVE

Application – Single- or double-acting cylinders.

Actuation – Lever operated, detent positioned.

Functions – Pos. 1 – Oil is directed to "advance" side of cylinder, oil from "retract" side goes to reservoir; cylinder "holds" with pump shut off. Pos. 2 – Oil goes to "retract" side of cylinder; cylinder "holds" with pump shut off. When using as a 3-way valve for single-acting cylinders, port "A" or "B" is plugged. See note on page 52 regarding plugging of ports and resulting heat build-up.

Used on these pumps – P460, PA6D, PA17, PA46, PA55, PA60, PE17, PE21, PE30, PE46, PE55, PE84, PE90, PE120, PE200, PE400, PQ60 and PQ120 series.

No. 9504 – 3/4-way/2-position manual valve. Wt., 1,9 kg.

NOTE: 9504 can be remote mounted with a 9510 subplate (see page 107).

NOTE: A pressure switch and/or gauge may be attached to any valve on this page. (refer to pages 117, 124-125)

CAUTION: To prevent sudden, uncontrolled descent of a load as it is being lowered, use a No. 9596 Load Lowering Valve or No. 9720 Counter Balance Valve (see page 132) in conjunction with the directional valve used in your application.

IMPORTANT: Conversion kit 251528 must be used when mounting any of the valves on this page on PA17 or PE17 pumps.

IMPORTANT: When ordering any valve for a PE30 or PG30 series pump, 1/2" longer mounting screws are required. For valves 9504, 9584, 9610 and 9610A, order four 12001 cap screws. For valve 9582, order two 12001 and two 10856 cap screws.

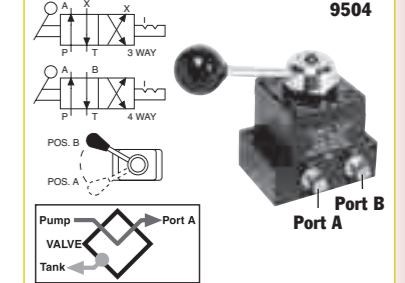
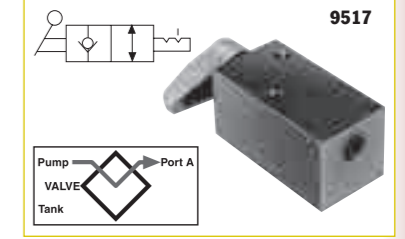
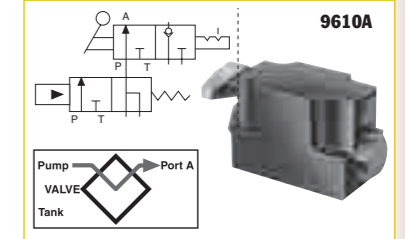
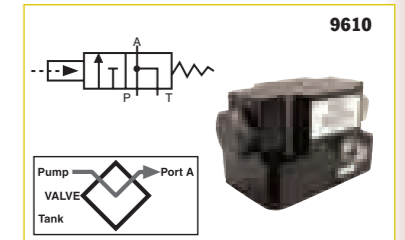
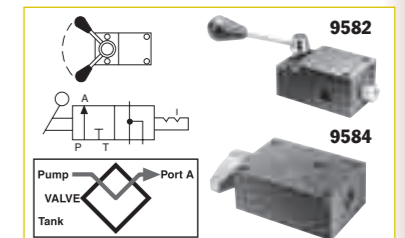

PUMPS/VALVES

Valves

HYDRAULIC PUMP MOUNTED

3 Way/3 Position Manual

700 bar, 3/8" ports, 19 l/min max flow rate.

PUMPS/VALVES

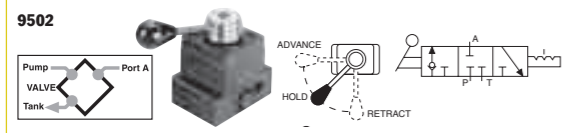

3-WAY/3-POSITION (CLOSED CENTER) NON-INTERFLOW MANUAL VALVE WITH "POSI-CHECK"

Application – Single-acting cylinders.
Actuation – Lever operated, detent positioned.
Functions – Pos. 1 – Oil is directed from pump to cylinder and "holds" with pump shut off; line to reservoir is blocked. Pos. 2 – All oil is open to reservoir through tank line.
Center pos. – Cylinder pressure is held; pump should be shut off.
Used on these pumps – P460, PA17, PA46, PA55, PA60, PE17, PE21, PE30, PE46, PE55, PE84, PE90, PE120, PE200, PE400, PQ60 and PQ120 series.
NOTE: A pressure switch and/or gauge may be attached if desired (see pages 124-125, 117). Also, the 9502 can be remote mounted if a 9510 subplate is used (see page 117).
No. 9502 – 3-way/3-position (closed center) manual valve. Wt., 1,9 kg.

CAUTION: To prevent sudden, uncontrolled descent of a load as it is being lowered, use a No. 9596 Load Lowering Valve or No. 9720 Counter Balance Valve (see page 132) in conjunction with the directional valve used in your application.
NOTE: Valves 9501, 9502, 9504 and 9507 can have a port blocked or have a closed center position. When a port is blocked and the valve is shifted to the blocked port, the pump will generate excessive heat. An electric or rotary air pump can either be turned off manually or with a pressure switch. Reciprocating air pumps may be adjusted to stall out and stop.
NOTE: Gauge ports monitor pump pressure only, not pressure to the hydraulic cylinder(s).
IMPORTANT: Conversion kit 251528 must be used when mounting any of the valves on this page on PA17 or PE17 pumps.
IMPORTANT: When ordering any valve for a PE30 or PG30 series pump, 1/2" longer mounting screws are required. For valves 9502 and 9520, order four 12001 cap screws. For valve 9576, order four 17428 cap screws.

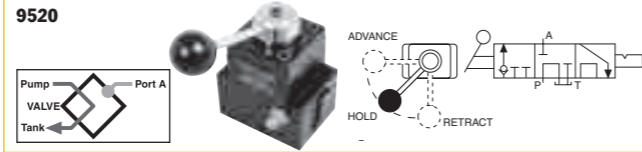

3-WAY/3-POSITION (TANDEM CENTER) MANUAL VALVE WITH "POSI-CHECK"

Application – Single-acting cylinders.
Actuation – Lever operated, detent positioned.
Functions – "Advance" "hold" and "return". When shifted to "return" position, pump and cylinder return oil through their own separate return lines, allowing faster retraction of piston. The "Posi-Check" feature guards against pressure loss when shifting from "advance" to "hold" position.
Used on these pumps – P460, PA17, PA46, PA55, PE17, PE21, PE30, PE46, PE55, PE84, PE90, PE120, PQ60, PQ120, PE200, PE400, PG30, PG55, PG120 and PG400 series.
No. 9520 – 3-way/3-position (tandem center) manual valve. Wt., 2,3 kg.

3-WAY/3-POSITION (TANDEM CENTER) METERING VALVE

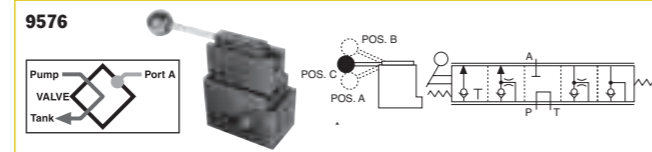

Application – Single-acting cylinders.
Actuation – Lever operated.
Functions – Cylinder piston metered "advance", "hold" and metered "return".
Used on these pumps – PA17, PA46, PA55, PE17, PE21, PE30, PE46, PE55, PE84, PE90, PE120, PQ60, PQ120, PE200, PE400, PG30, PG55, PG120 and PG400 series.
NOTE: A pressure switch and/or gauge may be attached if desired (see pages 124-125, 117). Also, the 9576 can be remote mounted with a 9510 subplate (see page 117).
No. 9576 – 3-way/3-position (tandem center) metering valve. Wt., 3,9 kg.

4-WAY/3-POSITION (TANDEM CENTER) VALVE WITH "POSI-CHECK"

Application – Double-acting cylinders.
Actuation – Lever operated, detent positioned.
Functions – "Advance", "hold" and "return". The "Posi-Check" feature guards against pressure loss when shifting from "advance" to "hold" position.
Used on these pumps – P460, PA6D, PA17, PA46, PA55, PE17, PE21, PE30, PE46, PE55, PE84, PE90, PE120, PE200, PE400, PED, PG30, PG55, PG120, PG400, PQ60 and PQ120 series
No. 9506 – 4-way/3-position (tandem center) manual valve. Wt., 2,3 kg.

4-WAY/3-POSITION (TANDEM CENTER) AND (OPEN-CENTER) MANUAL VALVES

Application – Single- or double-acting cylinders.
Actuation – Lever operated, detent positioned.
Functions – The 9500 provides "advance", "hold" and "return". The 9511 (open center) valve can be used if holding is not a requirement, as when running two separate hydraulic tools. Provides "advance" and "return" only.
Used on these pumps – P460, PA17, PA46, PA55, PE17*, PE21, PE30, PE46, PE55, PE84, PE90, PE120, PE200, PE400, PG30, PG55, PG120, PG400, PQ60 and PQ120 series. *Does not mount without 251528
No. 9500 – 4-way/3-position (tandem center) manual valve. Wt., 1,9 kg.
No. 9511 – Same as 9500, except has an open center.

4-WAY/3-POSITION (CLOSED CENTER) MANUAL VALVE WITH "POSI-CHECK"

Application – Single- or double-acting cylinders.
Actuation – Lever operated, detent positioned.
Functions – Similar to 9506, but is a closed center valve with "Posi-Check". Generally used to operate multiple cylinders with a single pump. Provides "advance", "hold" and "return". The "Posi-Check" feature guards against pressure loss when shifting from the "advance" to "hold" position. See note on page 46 regarding plugging of ports and resulting heat build-up.
Used on these pumps – P460, PA17, PA46, PA55, PA60, PA6D, PE17, PE21, PE30, PE46, PE55, PE84, PE90, PE120, PE200, PE400, PQ60 and PQ120 series.
No. 9507 – 4-way/3-position (closed center) manual valve. Wt., 2,3 kg.

4-WAY/3-POSITION (CLOSED CENTER) MANUAL VALVE

Application – Single- or double-acting cylinders.
Actuation – Lever operated, detent positioned.
Functions – "Advance", "hold" and "return". Closed center design makes valve suitable for operating multiple cylinders from a single pump. See note on page 52 regarding plugging of ports and resulting heat build-up.
Used on these pumps – P460, PA17, PA46, PA55, PA60, PE17, PE21, PE30, PE46, PE55, PE84, PE90, PE120, PE200, PE400, PQ60 and P120 series.
No. 9501 – 4-way/3-position (closed center) valve. Wt., 1,9 kg.

NOTE: A pressure switch and/or gauge may be attached to valves 9500, 9501, 9506, 9511 if desired (see pages 124-125, 117). Also, all valves on this page may be remote mounted with a 9510 subplate (see page 117).

Valves

HYDRAULIC PUMP MOUNTED

4 Way/3 Position Manual

700 bar, 3/8" ports, 19 l/min max flow rate.

PUMPS/VALVES

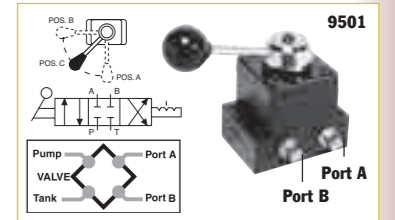
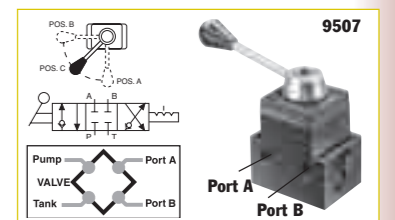
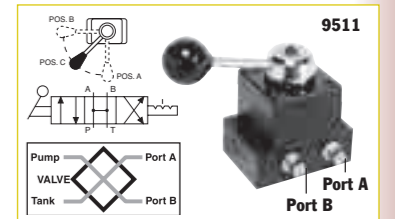
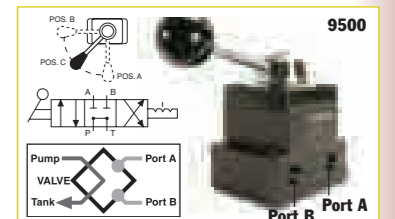
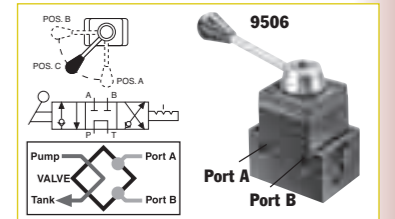

Valves

HYDRAULIC PUMP MOUNTED

Manual and Pilot Operated

700 bar, 3/8" ports, 19 l/min max flow rate.

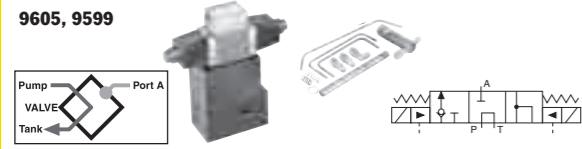
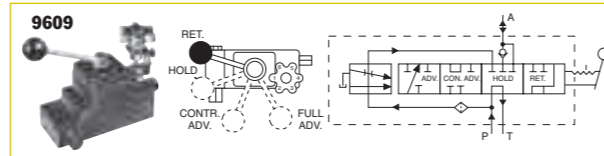

3-WAY/3-POSITION (TANDEM CENTER) SOLENOID VALVES WITH "POSI-CHECK"

Application – Single-acting cylinders.
Actuation – Solenoid operated: 9605 is 115 volt, 50/60 Hz; 9599 is 24 volt, 50 Hz.
Functions – “Advance”, “hold” and “return” positions. When in “advance”, solenoid “B” is energized and oil goes from pump to cylinder through pressure port. In “return” position, solenoid “A” is energized and oil is directed from cylinder and pump to reservoir. With both solenoids de-energized, in “hold” position, oil from pump is directed back to reservoir while oil is checked in cylinder. The “Posi-Check” feature holds load when shifting from “advance” to “hold” position.
Used on these pumps – Furnished with pilot lines and adapters for PE55, PE30 (carrying handles must be removed) and PE120 series. For application on other models, consult factory.
No. 9605 – 3-way/3-position (tandem center) solenoid valve, 115 volt, 50 Hz. Wt., 6,4 kg.
No. 9599 – Same as 9605 except for 24 volt, 50 Hz circuits.
NOTE: Valves above are shipped without controls. Use 202777 remote hand control (see page 116). Consult factory for field installation.

3-WAY/4-POSITION MANUAL PRESSURE COMPENSATED VALVE

Application – Single-acting cylinders. Primarily for use in testing soil, rock, concrete, asphalt and related engineering materials.
Actuation – Lever and adjustable, pressure compensated flow control valve.
Functions – Cylinder piston “return”, “hold”, “controlled advance” (pressure compensated) and “advance” (full flow). Will deliver a relatively constant flow regardless of pressure between 70 and 700 bar.
Used on these pumps – PA17, PA46, PA55, PE17, PE21, PE30*, PE46, PE55, PE90, PE200, PE400, PG30*, PG55, PG120, PG400, PQ60 and PQ120 series.
*** NOTE:** Adapter kit 252161 is required for mounting this valve to a PE30 or PG30 series pump.
NOTE: This valve can be remote mounted with a 9510 subplate (see page 117).
No. 9609 – 3-way/4-position manual pressure compensated valve. Wt., 4 kg.
CAUTION: To prevent sudden, uncontrolled descent of a load as it is being lowered, use a No. 9596 Load Lowering Valve or No. 9720 Counter Balance Valve (see page 132) in conjunction with the directional valve used in your application.
IMPORTANT: Conversion kit 251528 must be used when mounting the 9609 valve on PA17 or PE17 pumps.
IMPORTANT: When ordering any valve for a PE30 or PG30 series pump, 1/2" longer mounting screws are required. For valves 9500, 9501 and 9511, order four 12001 cap screws. For valve 9552, 9506, and 9507, order four 11956 cap screws. For valves 9599 and 9605, order four 251078 cap screws. For valve 9609, order four 10855 cap screws.

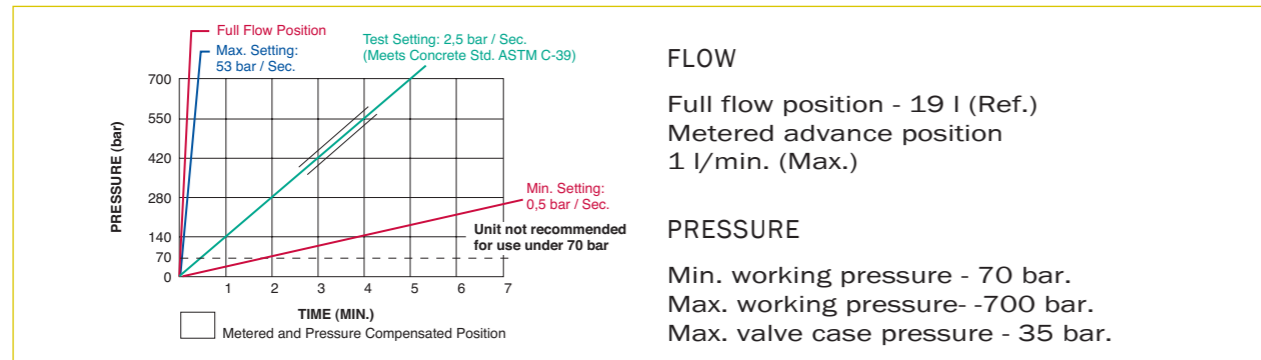

Valves

HYDRAULIC PUMP MOUNTED

Solenoid or Air Operated

700 bar, 3/8" ports, 19 l/min max flow rate.

3-WAY/2-POSITION SOLENOID VALVE

Application – Single-acting cylinders.
Actuation – Solenoid operated, 115 volt, 50 Hz.
Functions – Cylinder piston advances when solenoid is de-energized and pump is running. When solenoid is energized, oil is directed to reservoir, and piston returns. For “hold” position, pump is stopped with solenoid de-energized.
Used on these pumps – PE17, PE21, PE30, PE46, PE55, PE84, PE90, PE120, PE200, PE400, PQ60 and PQ120 series.
No. 9579 – 3-way/2-position solenoid valve, 115 volt, 50 Hz. Wt., 4,4 kg.
No. 9569 – Same as 9579, except with 24 volt, 50 Hz solenoid.
No. 9570 – Same as 9579 except with 230 volt, 50 Hz solenoid.
NOTES: Valves above are shipped without control switch. Use 202777 remote hand switch (see page 116). When this valve is mounted, the pump must be equipped with an outlet check valve.

3/4-WAY/2-POSITION SOLENOID VALVES

Application – Single- or double-acting cylinders. When used with single-acting cylinders, one port should be plugged.
Actuation – Solenoid operated.
Functions – Oil is directed to “extend” side of cylinder, oil from “retract” side goes to reservoir; cylinder “holds” with pump shut off. Oil is directed to “retract” side of cylinder; oil from “extend” side goes to reservoir.
NOTE: Cylinder will not “hold” in the “return” position with motor running or shut off.
Used on these pumps – 9552, 9572 and 9592 are used with PE17, PE30 (with carrying handles removed), PE46, PE55, PE84, PE90, PE200, PE400, PQ60 and PQ120 series.
No. 9592 – 3/4-way/2-position solenoid valve, 115 volt, 50 Hz. Wt., 6,6 kg.
No. 9552 – Same as 9592, except with 230 volt, 50 Hz solenoid.
No. 9572 – Same as 9592, except with 24 volt, 50 Hz solenoid.
NOTE: Valves above are shipped without controls. The 9552, 9572 and 9592 can be used with the 304718 remote hand control. (see page 116)
 Note: Ports are 1/4" NPTF.

AIR ACTUATED VALVE

Application – Single- or double-acting cylinders. When used with single-acting cylinders, one port should be plugged.
Actuation – Air operated.
Functions – Oil is directed to “extend” side of cylinder, oil from “retract” side goes to reservoir; cylinder “holds” with pump shut off. Oil is directed to “retract” side of cylinder; oil from “extend” side goes to reservoir.
NOTE: Cylinder will not “hold” in the “return” position with motor running or shut off.
Used on these pumps – PA17, PA46 and PA55 series.
No. 9594 – 3/4-way/2-position solenoid valve, air operated (minimum of 4 bar air pressure required). Wt., 5 kg.
NOTES: Valve above is shipped without controls. 9594 can be used with the 209593 remote hand control (see page 116). See page 132 for remote mounted models of this valve.

CAUTION: To prevent sudden, uncontrolled descent of a load as it is being lowered, use a No. 9596 Load Lowering Valve or No. 9720 Counter Balance Valve (see page 132) in conjunction with the directional valve used in your application.
IMPORTANT: Conversion kit 251528 must be used when mounting any of the valves on this page on PA17 or PE17 pumps.
IMPORTANT: When ordering any valve for a PE30 or PG30 series pump, 1/2" longer mounting screws are required. For valves 9569, 9570 and 9579, order four 10856 cap screws. For valves 9552, 9572 and 9592, order four 12001 cap screws.



PUMPS/VALVES

PUMPS/VALVES

Valves

HYDRAULIC PUMP MOUNTED

Solenoid or Air Operated

700 bar, 3/8" ports, 19 l/min max flow rate.

PUMPS/VALVES

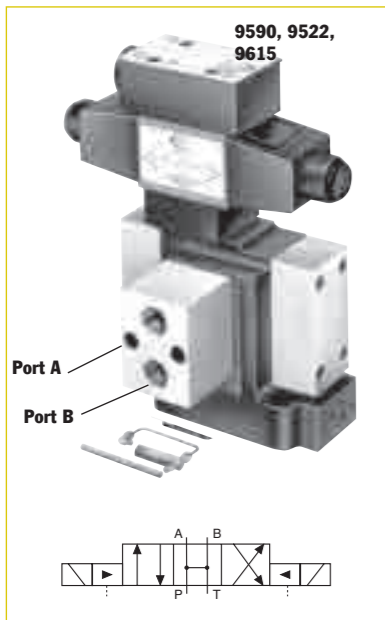

4-WAY/3-POSITION (OPEN CENTER) SOLENOID VALVE

Application – Double-acting cylinders.
Actuation – Solenoid operated, 115 volt, 50 Hz.
Functions – “Advance”, open center and “return” positions. Cylinder ports and pump port are open to reservoir in “neutral”.
Used on these pumps – Furnished with pilot lines and adapters for PE30 (with carrying handles removed), PE55, PE90 and PE120 series. For other pump models, consult factory.
NOTE: A pressure switch and/or gauge may be attached if desired (see pages 117, 124-125).
No. 9590 – 4-way/3-position (open center) solenoid valve, 115 volt, 50 Hz. Wt., 7 kg.
No. 9522 – Same as 9590 except for 230 volt, 50 Hz.
No. 9615 – Same as 9590 except for 24 volt, 50 Hz.

NOTE: Valves above are shipped without control switch. Use 202777 remote hand switch (see page 116).
CAUTION: To prevent sudden, uncontrolled descent of a load as it is being lowered, use a No. 9596 Load Lowering Valve or No. 9720 Counter Balance Valve (see page 132) in conjunction with the directional valve used in your application.
IMPORTANT: Conversion kit 251528 must be used when mounting the 9609 valve on PA17 or PE17 pumps.
IMPORTANT: When ordering any valve for a PE30 or PG30 series pump, 1/2" longer mounting screws are required. For valves 9513 and 9519, order four 11956 cap screws. For valves 9523, 9553 and 9589, order four 10855 cap screws. For valves 9522, 9590 and 9615, order four 10854 cap screws.

4-WAY/3-POSITION (TANDEM CENTER) PILOT OPERATED SOLENOID VALVE

Application – Double-acting cylinders.
Actuation – Solenoid operated, 115 volt, 50 Hz.
Functions – “Advance”, “hold” and “return”. The “Posi-Check®” feature holds the load when shifting from the “advance” to the “hold” position.
Used on these pumps – PE17, PE21, PE30 (with carrying handles removed), PE46, PE55, PE84, PE90, PE120, PE200, PE400, PQ60 and PQ120 series.
NOTE: A gauge may be attached if desired (see pages 124-125).
No. 9513 – 4-way/3-position (tandem center) solenoid valve, 115 volt, 50 Hz. Wt., 8,2 kg.
No. 9512 – Same as 9513 except for 24 volt, 50 Hz circuits.
No. 9516 – Same as 9513 except for 12 volt DC. For use on the PG1204S and PG400 series pumps only.
No. 9519 – Same as 9513 except for 230 volt, 50 Hz circuits. Consult factory for field installation.

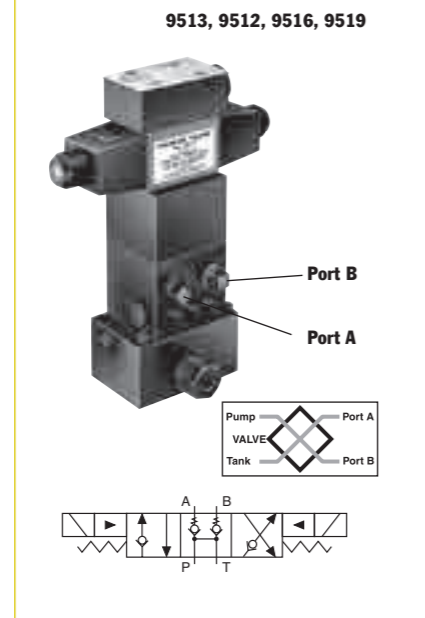

3-WAY/2-POSITION (PILOT OPERATED) SOLENOID VALVE

Application: Single-acting cylinders.
Actuation: Solenoid operated, 115 volt, 50 Hz.
Function: “Advance” and “return”.
Used on these pumps: Furnished with pilot lines and adapters for PE30 (with carrying handles removed), PE55, PE90 and PE120 series. For other pump models, consult factory. **NOTE:** A pressure switch and/or gauge may be attached if desired (see pages 117, 124-125).
No. 9589 – 3-way/2-position (pilot operated) solenoid valve, 115 volt, 50 Hz. Wt., 3,7 kg.
No. 9523 – Same as 9589 except for 230 volt, 50 Hz.
No. 9553 – Same as 9589 except for 24 volt, 50 Hz.

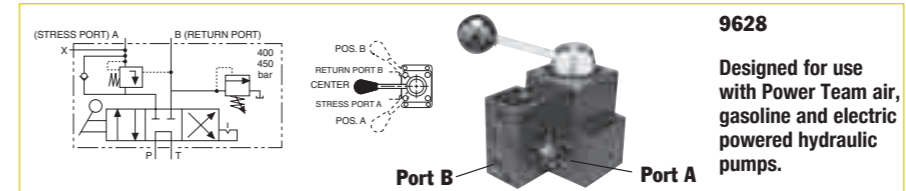

4-WAY/3-POSITION (TANDEM CENTER) MANUAL VALVE

Application – Single strand, double-acting stressing jacks with Power Wedge seater.
Actuation – Lever operated, detent positioned.
Operation –
 1. With valve in center position, pump is started.
 2. Cable is inserted into stressing tool, valve is placed in “A” position. “Pull” portion of stressing tool is pressurized to specified level for proper cable tensioning (“A” port is checked internally, can only be released by building pressure in “B” position).

3. Valve is placed in “B” position, which is pressure controlled and will not exceed 440 bar. “Return” portion of stressing tool is pressurized and will release “A” port when pressure reaches approximately one-half the “A” port pressure. “A” port remains open as long as this pressure differential is maintained.
4. Pump is stopped, valve is placed in “A” position, releasing “B” port pressure.

Used on these pumps: PA17*, PA46*, PA55, PE17*, PE21*, PE30, PE46*, PE55, PE60, PE84, PE120, PE200, PE400, PG30*, PG55, PG120, PG400, PQ60 and PQ120 series.

* These pumps may have reduced first flow stage characteristics due to internal valve restrictions.
No. 9628 – Post tensioning valve for 700 bar (max.) single-acting/Power Wedge seater. Wt., 2,5 kg.

“TWIN” 4-WAY/3-POSITION (TANDEM CENTER) MANUAL VALVE

Application – Multi-strand, double-acting stressing jacks with an auxiliary seating cylinder.
Actuation – Dual lever operated, detent positioned.
Operation –
 1. With valves “A” and “B” in center position, pump is started; cable is inserted into stressing tool.
 2. Valve “A” is placed in “Stress” position; cylinder extends to tension cable. Pump pressure controls force exerted by tensioning cylinder in this position. “Stress” port is checked internally, and can only be released by building pressure in the valve “B” return position.
 3. When desired cable tension is achieved, valve “A” is placed in valve “B” position and valve “B” in “Seat” position. Seating portion of cylinder will be pressurized to seating pressure

- controlled by “Seat” relief valve (factory set to 275 bar).
 4. Valve “B” is shifted to “Return” position, which is pressure controlled and will not exceed 155 bar. “Return” portion of stressing tool should be pressurized and will release “Stress” port when pressure reaches 15% of “Stress” port pressure.
 5. “Stress” port will remain open and cylinder will return as long as pressure differential is maintained. “Stress” and “Seat” ports are open to reservoir.
 6. When cylinder has fully returned, both valves are shifted to “Center” position and oil will be directed to reservoir. Maximum pressure setting for the “Seat” relief valve is 420 bar.

Used on these pumps: PA17*, PA46*, PA55, PE17*, PE21*, PE30, PE46*, PE55, PE84, PE120, PE200, PE400, PG30*, PG55, PG120, PG400, PQ60 and PQ120 series.*
 * These pumps may have reduced first flow stage characteristics due to internal valve restrictions.

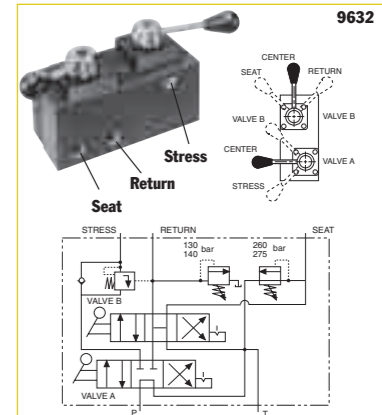

Pump mounted, 6-position detented 5-way manual dual valve. Rated pressure to valve “A” is 700 bar and valve “B” is 420 bar. Case pressure is 35 bar max.

CAUTION: To prevent sudden, uncontrolled descent of a load as it is being lowered, use a No. 9596 Load Lowering Valve or No. 9720 Counter Balance Valve (see page 132) in conjunction with the directional valve used in your application.
IMPORTANT: Conversion kit 251528 must be used when mounting any of the valves on this page on PA17 or PE17 pumps.
IMPORTANT: When ordering any valve for a PE30 or PG30 series pump, 1/2" longer mounting screws are required. For valves 9569, 9570 and 9579, order four 10856 cap screws. For valves 9552, 9572 and 9592, order four 12001 cap screws.



Valves

HYDRAULIC PUMP MOUNTED

Manual

700 bar, 3/8" ports, 19 l/min max flow rate.

PUMPS/VALVES

Hand Pump

HYDRAULIC P SERIES

197 to 738 cm³ reservoir
Single-Speed
Single-Acting

Best suited for applications where there is little or no free travel.

- All metal construction, won't burn through in welding environments.
- Formed metal handle provides less flex, and reduces operator fatigue.
- Convenient fill port on P23 and P55 allows pumps to be filled in a horizontal or vertical position.
- Fill cap seal acts as safety valve preventing over-pressurizing of reservoir.
- Relief valve inboard of check valve prevents loads from drifting down.
- Large valve knob gives added control for slowly metering loads down.

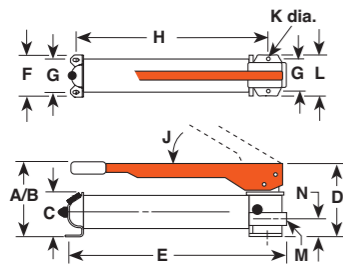

Power Team hand pumps, with the angled fill port, have a built in "relief valve" protection system. This system is designed to protect over-pressurization of the reservoir from sudden back pressure. This system also works as a seal to prevent oil leaks.

Pump No.	A (mm)	B (mm)	C (mm)	D (mm)	E (mm)	F (mm)	G (mm)	H (mm)	J (deg.)	K (mm)	L (mm)	M (in)	N (mm)
P12	101,6	—	—	101,6	342,9	85,7	55,6	—	45°	4,8	85,7	3/8-NPTF	28,6
* P23	158,8	330,2	88,9	141,3	346,1	108,0	82,6	261,6	38°	7,9	120,7	3/8-NPTF	41,3
* The P23 pump maximum pressure is 210 bar only.													
P55	165,1	533,4	88,9	141,3	584,2	108,0	82,6	501,7	38°	7,9	120,7	3/8-NPTF	41,3

For Use With	Order No.	Volume & Pressure				Reservoir		Handle Effort (kg)	Oil Capacity (cm ³)	Usable Oil Capacity (cm ³)	Oil Port (in)	Product Weight (kg)
		Speed	Volume per Stroke (cm ³)	Maximum Pressure (bar)	Volume per Stroke (cm ³)	Oil Capacity (cm ³)	Usable Oil Capacity (cm ³)					
Single Acting	P12	1	—	1,1	—	700	34	197	148	3/8-NPTF	2,6	
Cylinders*	P23	1	—	2,6	—	210	32	390	333	3/8-NPTF	5,5	
	P55	1	—	2,6	—	700	66	902	738	3/8-NPTF	7,2	

LP = Low Pressure
HP = High Pressure

* Pump includes 2-Way Valve

Hand Pump

HYDRAULIC P SERIES

400 to 1131 cm³ reservoir
Two-Speed
Single-Acting

Pump automatically shifts into the high pressure lift stage upon contact with the load.

700 bar



- All metal construction won't burn through in welding environments.
- Two-speed reduces handle strokes so you work faster and easier.
- Formed metal handle provides less flex, and reduces operator fatigue.
- Convenient fill port allows pumps to be filled in a horizontal or vertical position.
- Relief valve inboard of check valve prevents loads from drifting down.
- Large valve knob gives added control for slowly metering loads down.

P19L/P59L

- More usable oil volume — use with larger or longer stroke cylinders.
- True unloading valve set for 850 PSI (59 Bar) provides more efficiency and lower handle force.
- Link design reduces handle effort by 40%.
- Durable aluminum reservoir, manifold, and end cap.
- Ergonomic non-slip handle grip provides more comfort.
- Spring loaded handle lock incorporated into handle.

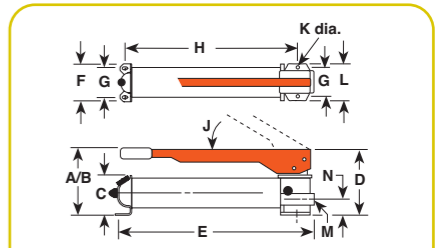

Pump No.	A (mm)	B (mm)	C (mm)	D (mm)	E (mm)	F (mm)	G (mm)	H (mm)	J (deg.)	K (mm)	L (mm)	M (in)	N (mm)
P19	139,7	371,5	73,0	115,9	347,7	101,6	82,6	281,0	53°	7,9	101,6	3/8-NPTF	35,7
P19L	141,5	—	—	—	347,7	104,1	82,6	281,0	40°	7,9	104,1	3/8-NPTF	—
P59	177,8	533,4	88,9	127,0	584,2	108,0	82,6	501,7	38°	7,9	120,7	3/8-NPTF	41,3
P59L	177,8	—	—	—	533,4	120,7	82,6	501,7	50°	7,9	120,7	3/8-NPTF	—
P59F	88,9	425,5	88,9	152,4	590,6	108,0	82,6	514,4	—	7,9	114,3	3/8-NPTF	42,9

For Use With	Order No.	Volume & Pressure				Handle Effort (kg)	Reservoir		Oil Port (in)	Product Weight (kg)	
		Speed	Volume per Stroke (cm ³)	Maximum Pressure (bar)	Volume per Stroke (cm ³)		Oil Capacity (cm ³)	Usable Oil Capacity (cm ³)			
Single Acting	P19	2	5,0	1,2	22	700	45	400	328	3/8-NPTF	3,0
Cylinders*	P19L	2	4,1	0,9	59	700	37	475	443	3/8-NPTF	2,3
	P59	2	10,9	2,6	22	700	66	902	738	3/8-NPTF	7,8
	P59L	2	12	2,6	59	700	44	1131	1082	3/8-NPTF	4,1
	P59F	2	9,0	2,1	22	700	55	902	738	3/8-NPTF	6,4

LP = Low Pressure
HP = High Pressure

*Pump includes 2-Way Valve



Hand Pump HYDRAULIC P SERIES

9,5 liter reservoir
Two-Speed Single-
and Double-Acting

Best suited for applications
where there is little or
no free travel.

- Rugged all metal construction for strength and durability that won't burn through in welding environments.
- Heavy-duty, formed metal handle provides less flex, and less operator fatigue than round or composite handles.
- Convenient fill port on P23 and P55 allows pumps to be filled in a horizontal or vertical position.
- Fill cap seal acts as safety valve to prevent over-pressurizing of reservoir.
- Relief valve inboard of check valve prevents loads from drifting down.
- Large valve knob gives added control for slowly metering loads down.



P157/P159



P300



P460

P300 hand pump and 10 ton cylinders used for a vehicle lift.

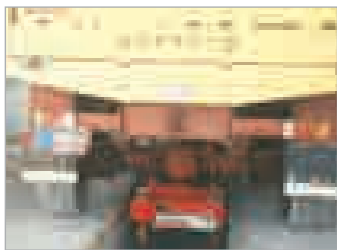

PUMPS

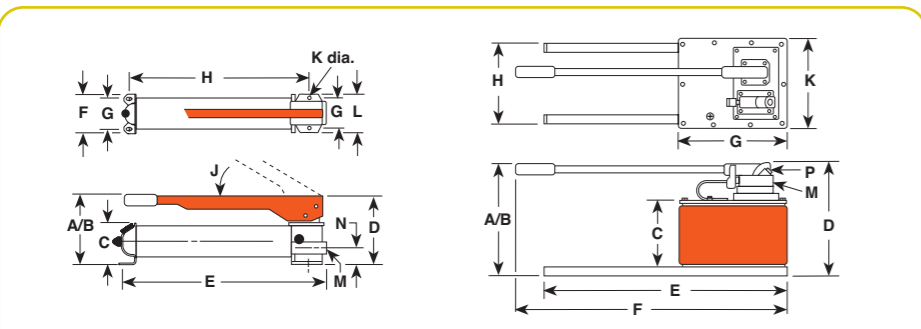

FK59
FK159B

Foot pump conversion kit
No. **FK59** - Foot pump conversion kit for use on P55/P59 pumps. Wt., 2,7 kg.
No. **FK159B** - Foot pump conversion kit for use on P157/P159 and P300/P300D pumps. Wt., 2,7 kg.

Pump No.	A (mm)	B (mm)	C (mm)	D (mm)	E (mm)	F (mm)	G (mm)	H (mm)	J (deg.)	K (mm)	L (mm)	M (in)	N (mm)	P
P157/P159	197	521	123,8	175	578	98,4	76,2	502	39°	7,9	95,3	3/8-NPTF	57,2	-
P300	210	533	114,3	175	575	215,9	190,5	526	39°	7,9	95,3	3/8-NPTF	57,2	-
P460	283	787	171,5	289	610	743	279,4	229	80°	241,3	-	3/8-NPTF	-	1/4 NPTF

For Use With	Order No.	Speed	Volume & Pressure		Maximum Pressure (bar)		Handle Effort (kg)	Reservoir Oil Capacity (cm³)	Usable Oil Capacity (cm³)	Oil Port (in)	Product Weight (kg)
			Volume per Stroke (cm³)	HP	LP	HP					
Single-Acting	P157	2	10,7	2,6	97	700	64	2491	2245	3/8-NPTF	11,8
Cylinders*	P159	2	42,6	2,6	22	700	64	2491	2245	3/8-NPTF	11,8
	P300	2	42,6	2,6	22	700	64	5.700	5081	3/8-NPTF	25,1
	P460	2	120,5	4,6	22	700	41	9.500	7539	3/8-NPTF	24,9
Double-Acting	P157D	2	10,7	2,6	97	700	64	2491	2245	3/8-NPTF	13,1
Cylinders**	P159D	2	42,6	2,6	22	700	64	2491	2245	3/8-NPTF	12,7
	P300D	2	42,6	2,6	22	700	64	5.700	5081	3/8-NPTF	25,9
	P460D	2	120,5	4,6	22	700	41	9.500	7539	3/8-NPTF	26,3

LP = Low Pressure
HP = High Pressure

* Pump includes 2-Way Valve
** Pump includes 4-Way Valve

Cylinder/Pump HYDRAULIC RPS SERIES

Cylinder and pump combinations

Precision-matched cylinder and pump combinations for wide range of applications.

- Four styles of cylinders to choose from.
- Sets feature single- or two-speed hydraulic hand pumps.
- Cylinders of various tonnages with long, medium or short stroke.
- Includes necessary fittings, couplers and 1,8m hose.
- Gauge and gauge mounting adapter is recommended. (See pages 124-125)



RPS1006



RPS55

700 bar
ASMEB30-1



RPS203H

Optional Storage Box Storage box for hydraulic cylinder and pump sets. Rugged industrial strength material, strong as steel, never needs painting, won't rust, dent or chip. Weatherproof lid is self sealing and lockable. Molded-in handles, water-tight, one piece bottom and side construction. Strong enough to stand on.
No. **350722** - 890mmL x 356mmH x 343mmW, storage box.



Note: Actual product may differ from photo.

PUMPS

Style Of Cyl.	Cyl. Cap. (Tons)	Stroke (mm)	Order No.	Retracted Height (mm)	Handle Strokes Required to Fully Extended Cylinder	Cyl. No.	Pump No.	Hose No.	Coupler No.	Pump Speed	Prod. Wt. (kg)
	5	133,4	RPS55	216	75	C55C	P12	9756	9798	Single	5,4
	10	54,0	RPS102**	121	32	C102C	P55	9756	9798	Single	11,8
	10	155,6	RPS106**	248	93	C106C	P55	9756	9798	Single	14,5
	10	257,2	RPS1010**	349	154	C1010C	P55	9756	9798	Single	16,1
"C"-Series	15	104,8	RPS154**	200	81	C154C	P55	9756	9798	Single	13,1
	15	155,6	RPS156**	271	118	C156C	P55	9756	9798	Single	15,4
	25	158,8	RPS256**	273	219	C256C	P55	9756	9798	Single	19,3
	25	362,0	RPS2514**	476	285*	C2514C	P159	9756	9798	Two	28,4
	55	158,8	RPS556**	283	268*	C556C	P159	9756	9798	Two	37,5
	100	168,3	RPS1006	337	428*	C1006C	P460	9756	9798	Two	58,3
"Shorty"	30	61,9	RPS302**	117	61*	RSS302	P59	9756	9798	Two	18,1
	50	60,3	RPS552**	127	89*	RSS502	P59	9756	9798	Two	22,7
	100	57,2	RPS1002**	140	172*	RSS1002	P59	9756	9798	Two	36,7
"Center-Hole"	20	76,2	RPS203H**	154	80	RH203	P55	9756	9798	Single	18,3
Alum.	55	155,6	RPS556A**	273	262*	RA556	P159	9756	9798	Two	21,3

* Base on 50% if the stroke being made at low-pressure and 50% of the strokes at high pressure.

** Add suffix "B" (example: RPS102B, RPS203HB, etc.) to order set with optional storage box shown above.



Air Pump

HYDRAULIC PAG SERIES

90 cm³/ min
Single-Acting

Compact, lightweight and portable. Single-Speed pumps designed to drive single-acting cylinders.



- Usable in hazardous areas: per ATEX II, 2 GDc T5
- The power unit of choice for major manufacturers of auto body, frame straighteners and other equipment.
- Operate at 3-8 bar shop air pressure at the pump.
- dBA 85 at 700 bar.
- Serviceable pump motor is not a “throw away”, providing economical repair.
- Permanently vented reservoir cap.
- Internal relief valve protects circuit components, air inlet filter protects motor.



PA6M-1



PA6

700 bar

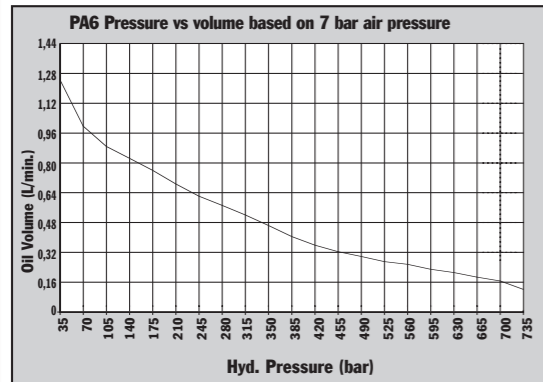

PUMPS

PUMPS

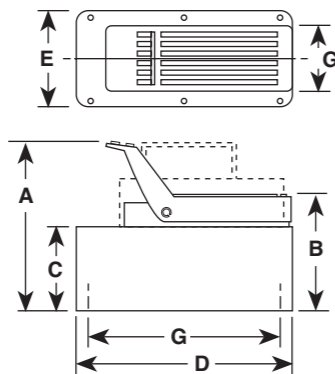

Pump No.	A (mm)	B (mm)	C (mm)	D (mm)	E (mm)	G (mm)
PA6	197	149	111	241	127	102 x 229
PA6A	197	149	111	241	127	102 x 229
PAGAM	197	149	111	241	127	102 x 229
PA6M	197	149	111	241	127	102 x 229
PA6R	197	149	111	241	127	102 x 229
PA6RM	197	149	111	241	127	102 x 229
PA6M-1	200	152	111	321	187	—
PA6AM-2	254	197	171	292	241	203 x 254
PA6-2	260	203	178	292	241	130 x 181

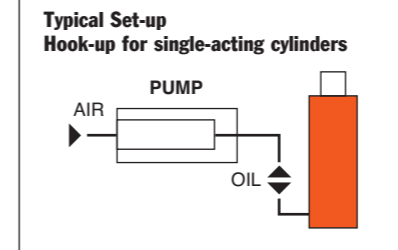

PA6-2

Description	Order No.	Air Supply Req'd (bar)	Reservoir Cap. (l)	Reservoir Usable (l)	Oil Port (in)	Prod. Wt. (kg)
Base model pump with high density polyethylene reservoir.	PA6	3-8	1,7	1,6	3/8-NPTF	6,3
PA6 with externally adjustable relief valve.	PA6A	3-8	1,7	1,6	3/8-NPTF	6,8
PA6A with metal reservoir.	PAGAM	3-8	1,7	1,6	3/8-NPTF	7,7
PA6, except has metal reservoir.	PAGM	3-8	1,7	1,6	3/8-NPTF	8,2
PA6 with 3,7m remote control.	PA6R	3-8	1,7	1,6	3/8-NPTF	9,3
PA6R, except has metal reservoir.	PA6RM	3-8	1,7	1,6	3/8-NPTF	9,8
PA6, except has 3,8 l metal reservoir.	PA6M-1	3-8	3,8	3,0	3/8-NPTF	10,7
PA6, except has 7,6 l high density polyethylene reservoir.	PA6-2	3-8	7,6	7,3	3/8-NPTF	11,1
PA6, except has 9,5 l metal reservoir.	PA6M-2	3-8	9,5	9,1	3/8-NPTF	14,5



Air Pump

HYDRAULIC PA6D SERIES

98 cm³/min.
Double-Acting

Compact, lightweight and portable single-speed pump for driving double-acting cylinders.

- Usable in hazardous areas: per ATEX II, 2 GDC T5
- Operate at 3-8 bar shop air pressure at the pump.
- Internal relief valve protects circuit components, air inlet filter protects motor.
- Serviceable pump motor is not a “throw away”, providing economical repair.
- Permanently vented reservoir cap.
- dBA 85 at 700 bar for all PA6 pumps.
- * input air port inside thread size 1/4”NPT



PA6D

700 bar

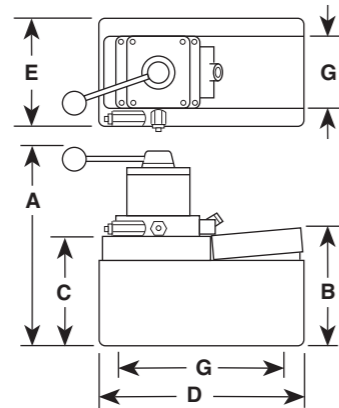
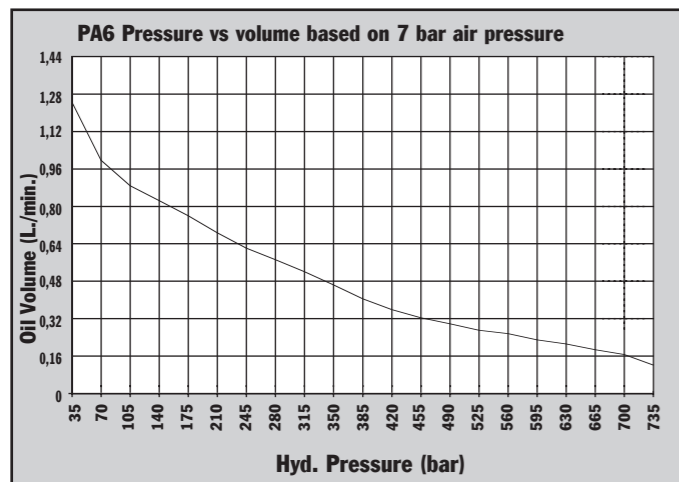

Pump No.	A (mm)	B (mm)	C (mm)	D (mm)	E (mm)	G (mm)
PA6D	264	149	111	241	127	102 x 229
PA6DM	264	149	111	241	127	102 x 229
PA6DM-1	279	146	111	321	187	—
PA6D2	324	203	178	287	235	130 x 181
PA6DM-2	318	197	171	292	241	203 x 254



PA6DM-1



PA6D2



PA6D pump, DG100 digital pressure gauge and 25 ton cylinder used in a test fixture.

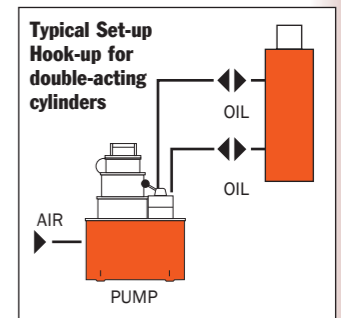

Description	Order No.	Valve No.	Air Supply Req'd (bar)	Reservoir Cap. (l)	Reservoir Usable (l)	Oil Port (in)	Prod. Wt (kg)
Base model pump with high density polyethylene reservoir.	PA6D	9504, 3-way/4-way	3 - 8	1,7	1,6	3/8-NPTF	8,3
PA6D, except has metal reservoir.	PA6DM	9504, 3-way/4-way	3 - 8	1,7	1,6	3/8-NPTF	9,2
PA6D, except has 3,8 l metal reservoir.	PA6DM-1	9504, 3-way/4-way	3 - 8	3,8	3,0	3/8-NPTF	12,7
PA6D, except has 7,6 l, high density polyethylene reservoir.	PA6D2	9504, 3-way/4-way	3 - 8	7,6	7,3	3/8-NPTF	13,0
PA6D, except has 9,5 l metal reservoir.	PA6DM-2	9504, 3-way/4-way	3 - 8	9,5	9,1	3/8-NPTF	16,4



Air Pump HYDRAULIC PA9 SERIES

148 cm³/min.
Single-Acting

Ideal for powering single-acting cylinders and portable hydraulic tools.

- Easier to operate than a hand pump, giving you the speed you need at an affordable price.
 - Easy and economical to service; not a "throw away" unit.
 - Unique bladder design for all-position operation and storage.
 - Operates on 3-8 bar shop air, at 570 l.
 - Hard-coat anodized aluminum housing.
 - Oil filler with integral safety relief minimizes chance of damage to reservoir bladder if overfilling occurs.
- * input air port inside thread size 1/4"NPT

PA9 Foot Control



PA9
Foot Control



PA9H
Hand Control

700 bar



PA9H Hand Control Pump as used in a straightening press.

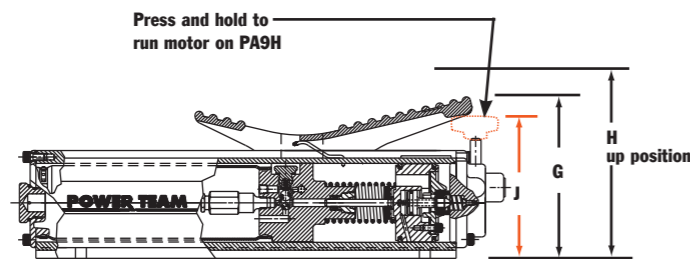
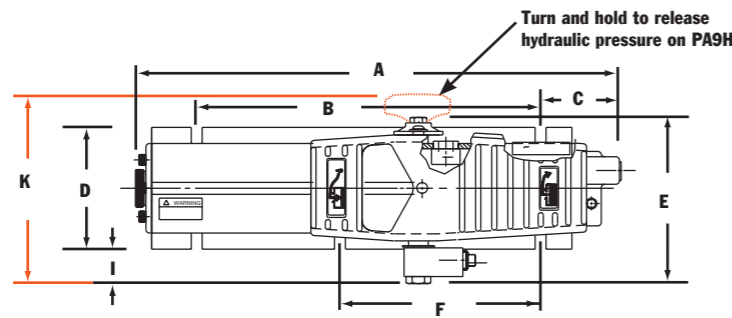

Relief valve settings: up to 700 bar
Mounting holes (standard): 3/8" slots

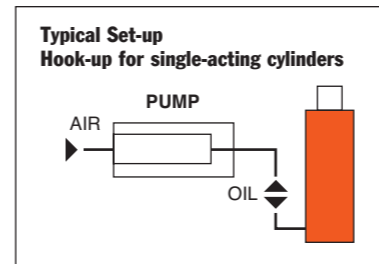
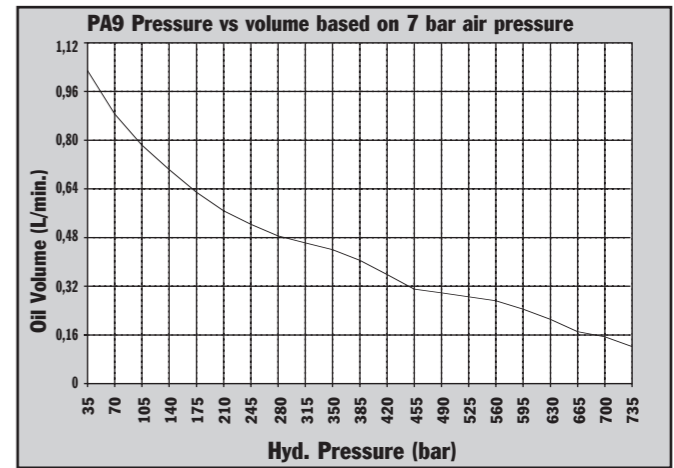

For Use with Cyl. Type	Order No.	Air Supply Req'd (bar)	Reservoir Cap. (cm ³)	Reservoir Usable (cm ³)	Oil Port (in)	Max. Pressure Output (bar)	Prod. Wt. (kg)
Single-Acting	PA9	3 - 8	574	549	3/8-NPTF	700	6,8
Single-Acting	PA9H	3 - 8	574	549	3/8-NPTF	700	6,8

Pump No.	A (mm)	B (mm)	C (mm)	D (mm)	E (mm)	F (mm)	G (mm)	H (mm)	I (mm)	J (mm)	K (mm)
PA9	432	305	71,4	108	149	178	142	178	28,2	—	—
PA9H	432	305	71,4	108	—	178	—	178	28,2	122	170



Air Pump

HYDRAULIC PA60 SERIES

98 cm³/min.
Two-Speed

- Equipped with air pressure regulator, air filter and lubricator.
- Serviceable air motor for economical repair.
- Internal relief valve protects circuit components.
- Permanently vented reservoir cap.



The PA60 used in a workholding environment.

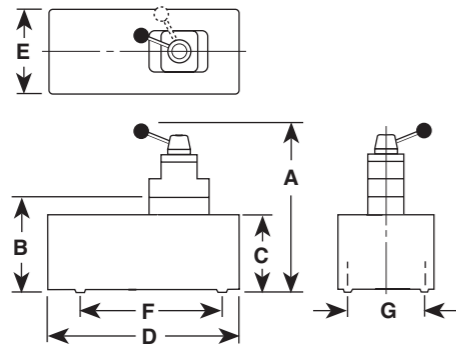

Pump No.	A (mm)	B (mm)	C (mm)	D (mm)	E (mm)	F (mm)	G (mm)	Max. Pressure Output bar	Oil Del. * (l/min)				
									0 bar	7 bar	70 bar	350 bar	700 bar
PA60	—	240	206	362	244	181	130	700	6,24	5,6	0,8	0,19	0,1
PA64	362	—	206	362	244	181	130	700	6,24	5,6	0,8	0,19	0,1

* Typical delivery. Actual flow will vary with field conditions.

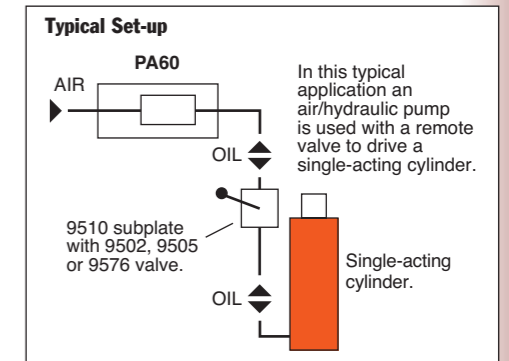
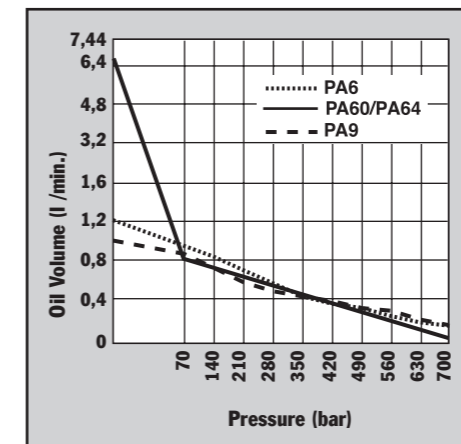
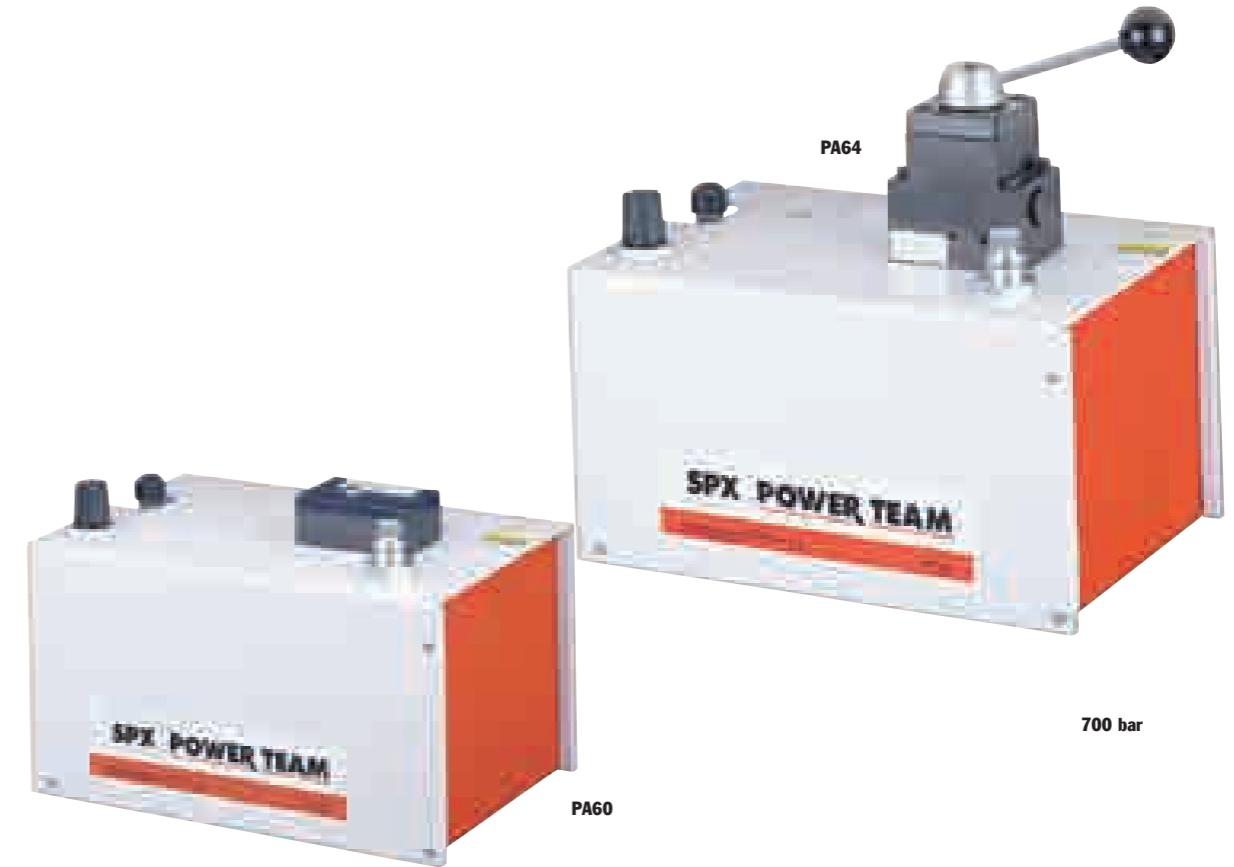

Description	Order No.	Valve No.	Valve Function	Air Supply Req'd bar	Reservoir Cap. (l)	Reservoir Usable (l)	Oil Port (in)	Prod. Wt (kg)
For use with remote valves.	PA60	Manifold	—	3 - 8	7,6	6,8	3/8-NPTF	24,5
For use with single- or double-acting cylinders.	PA64	9507, 3-way/4-way	Advance Hold Return	3 - 8	7,6	6,8	3/8-NPTF	24,5

Notes: Air inlet port 1/4" NPTF. Requires 570 l at 7 bar shop air pressure at the pump.



Air Pump

HYDRAULIC PA50 SERIES

460 cm³/min.
Low Pressure

Single-speed, low pressure
(220 bar) output pumps.

PUMPS

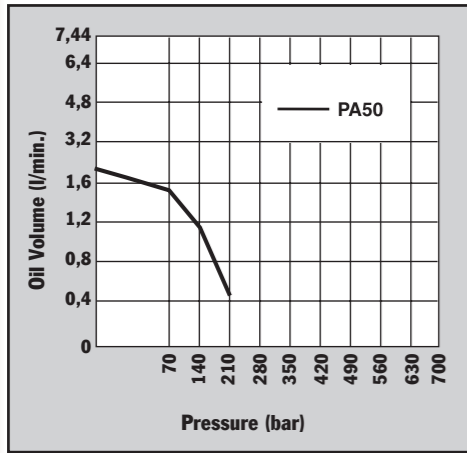

- Serviceable air motor for economical repair.
 - Air inlet filter protects motor. Filter in outlet port protects against contaminated systems.
 - Assorted reservoirs to suit your application's requirements.
- * input air port inside thread size 1/4"NPT

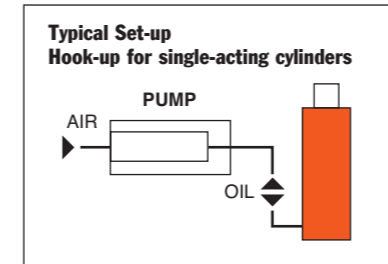

PUMPS

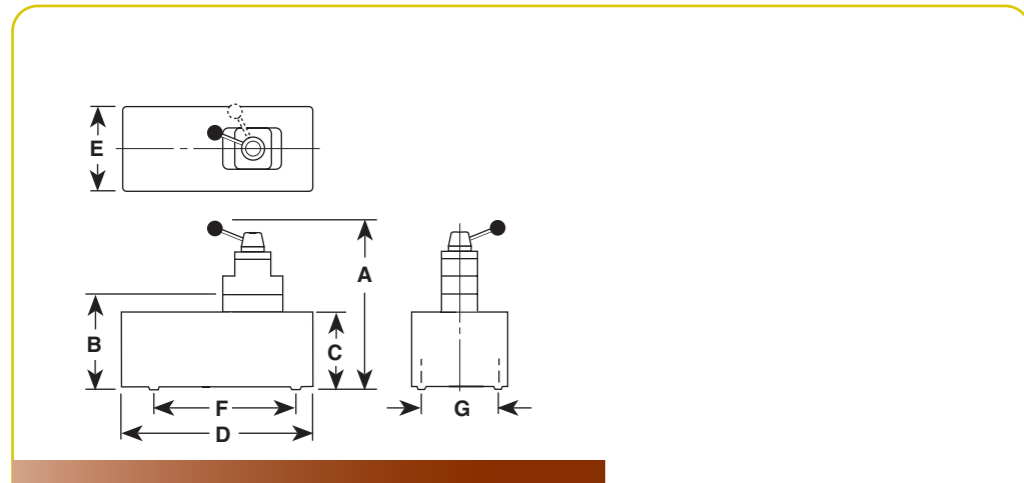

Pump No.	A (mm)	B (mm)	C (mm)	D (mm)	E (mm)	F (mm)	G (mm)	Max. Pressure Output		Oil Del. * (l/min)		
								bar	0 bar	7 bar	70 bar	220 bar
PA50, PS50R								220	2,05	1,76	1,41	0,45 †
PA50M, PA50RM	197	149	111	241	127	—	102 x 229	220	2,05	1,76	1,41	0,45 †
PA50R2	260	203	178	292	241	—	130 x 181	220	2,05	1,76	1,41	0,45 †
PA50D	264	149	111	241	127	229	102	220	2,05	1,76	1,41	0,45 †

* Typical delivery. Actual flow will vary with field conditions.
† PA50 Series measured at 220 bar.

For use with Cyl. Type	Description	Order No.	Valve No.	Air Supply Req'd bar	Reservoir Cap. (l)	Usable (l)	Oil Port (in)	Prod. Wt (kg)
Single-Acting	Base model pump with high density polyethylene reservoir.	PA50	—	3 - 8	1,7	1,6	3/8-NPTF	6,4
Single-Acting	PA50, except has metal reservoir.	PA50M	—	3 - 8	1,7	1,6	3/8-NPTF	7,3
Single-Acting	PA50, except has 3.7 meter 12 foot remote control.	PA50R	—	3 - 8	1,7	1,6	3/8-NPTF	8,4
Single-Acting	PA50R, except has metal reservoir.	PA50RM	—	3 - 8	1,7	1,6	3/8-NPTF	9,3
Single-Acting	PA50R, except has 7.6 liter reservoir 2 gallon reservoir.	PA50R2	—	3 - 8	7,6	7,3	3/8-NPTF	12,9
Single- and Double Acting	PA50, except designed to operate either single- or double-acting systems. Valve function: Advance/Return.	PA50D	9504, 3-way/4-way	3 - 8	1,7	1,6	3/8-NPTF	8,3

Notes: Air inlet port 1/4" NPTF. Requires 570 l at 7 bar shop air pressure at the pump.



Air Pump

HYDRAULIC PA17 SERIES

279 cm³/min.
Two Speed

- Two-speed operation for high speed cylinder advance.
- Durable 7,6 liter thermoplastic reservoir. (Metal reservoir conversion kits are available.)
- Features air motor capable of starting under full load.



The PA17 used with a flange spreader

Rotary-style air motor. Use where air is preferred source of energy, where electricity is unavailable or sparks are a concern.

PUMPS

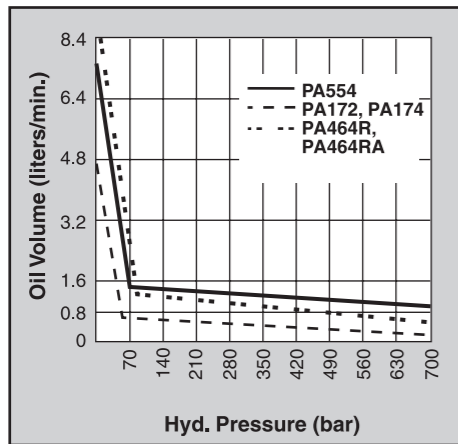

PA172



PA174

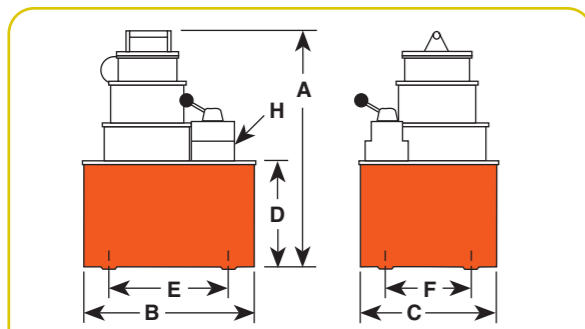
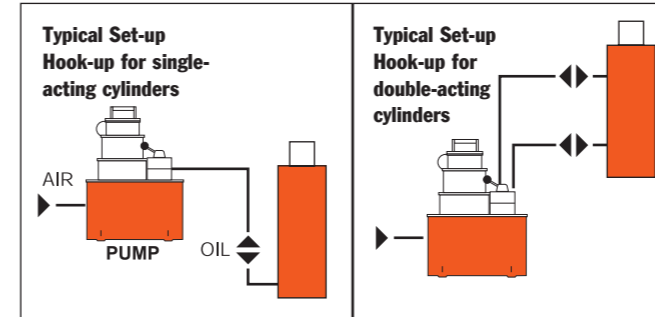

Pump No.	A (mm)	B (mm)	C (mm)	D (mm)	E (mm)	F (mm)	H (mm)	Oil Del. * (l/min)					
								Max. Pressure Output bar	0 bar	7 bar	70 bar	350 bar	700 bar
PA172	359	289	235	178	181	130	³ / ₈ -NPTF	700	4,6	3,8	0,4	0,4	0,3
PA174	359	289	235	178	181	130	³ / ₈ -NPTF	700	4,6	3,8	0,4	0,4	0,3

* Typical delivery. Actual flow will vary with field conditions.

PUMPS

For use with Cyl. Type	Description	Order No.	Valve No.	Valve Function	Air Supply Req'd bar	Reservoir Cap. (l)	Reservoir Usable (l)	Prod. Wt (kg)
Single-Acting	Base model pump with 7.6 liter 2 gallon thermoplastic reservoir.	PA172	9517, 2-way	Advance/Return*	3 - 8	7,6	4,7	18,1
Single- and Double Acting	PA172, except has 9500 valve for use with single- or double-acting cylinders.	PA174	9500, 4-way	Advance Hold Return*	3 - 8	7,6	4,7	18,6

Note: Requires 570 l at 6 bar shop air pressure at the pump. dBA 85/90 at 700 bar.

* Holds pressure in advance position when valve motor is shut off, in return position with motor running. Pump will build pressure when motor is shut off, oil returns to reservoir.



Air Pump

HYDRAULIC PA46/55 SERIES

Up to 150 ton Cylinders
754-902 cm³/min.
Two Speed

Rotary-style air motor.
Use where air is the preferred
source of energy.

- 2,2 kW motor starting under full load.
- Two-speed operation for rapid cylinder advance.
- Models available with full remote control over advance and return, (except PA554).
- Tandem center valve holds the load when pump is shut off.



PA554 pump and RH2008 Center Hole cylinder used to tension cables.



PUMPS

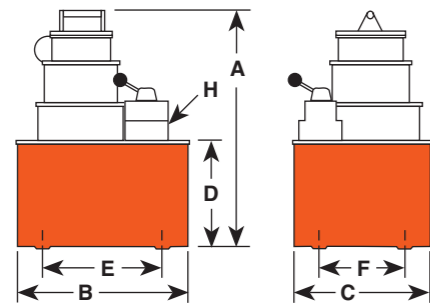
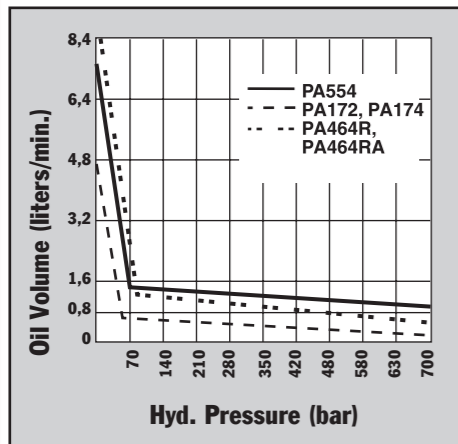

Pump No.	A (mm)	B (mm)	C (mm)	D (mm)	E (mm)	F (mm)	H (mm)	Max. Pressure Output bar	Oil Del. * (l/min)				
									0 bar	7 bar	70 bar	350 bar	700 bar
PA462	381	292	241	178	254	203	3/8 NPTF	700	7,4	7,2	0,8	0,8	0,7
PA464	381	292	241	178	254	203	3/8 NPTF	700	7,4	7,2	0,8	0,8	0,7
PA464R	381	292	241	178	254	203	3/8 NPTF	700	7,4	7,2	0,8	0,8	0,7
PA464RA	381	292	241	178	254	203	3/8 NPTF	700	7,4	7,2	0,8	0,8	0,7
PA554	483	292	241	178	254	203	3/8 NPTF	700	7,4	7,2	1,3	1,1	0,7

* Typical delivery. Actual flow will vary with field conditions.
Note: Four mounting holes 1/2" - 20

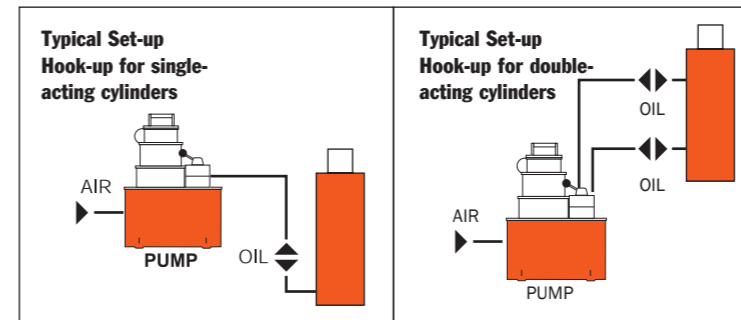

For use with Cyl. Type	Description	Order No.	Valve No.	Valve Function	Air Supply Req'd bar	Reservoir Cap. (l)	Usable (l)	Prod. Wt (kg)
Single-Acting	Base model pump with 9,5 l steel reservoir.	PA462	9584,	Advance/Hold/Return	3 - 8	9,5	9,4	27,2
Single- and Double Acting	PA462, except has 9500 valve capable of running 2 single-acting cylinders or one double-acting cylinder.	PA464	9500,	Advance/Hold/Return*	3 - 8	9,5	9,4	27,6
Single- and Double Acting	PA462 with air actuated valve for full remote control over advance and return. Includes 3,7m remote control.	PA464R†	9594,	Advance/Hold/Return	3 - 8	9,5	9,4	35,3
Single- and Double Acting	PA464R except, has automatic dump feature. 7,6 m remote control.	PA464RA	**†	9594, Return*	Advance/Hold/	3 - 8	9,5	9,4
Single- and Double Acting	High performance pump with 9,5 l steel reservoir.	PA554	9500,	Advance/Hold/Return*	3 - 8	9,5	8,4	32,0

Note: Requires 570 l at 6 bar shop air pressure at the pump. dBA 85/90 at 700 bar.

* Holds when motor is shut-off and valve is in "advance" position.

† The PA464RA has an "automatic dump" feature. Pressure is not held when operator releases "advance" or "return" button. PA464R will "hold" only in the "advance" position with the motor shut off.

** Not to be used for lifting.

PUMPS



Air Operated PUA & PMA SERIES

2410 bar

Suitable for pumping a wide range of fluids at pressures up to 35,000 psi (2,410 bar).



- Provides infinitely variable capacity and discharge pressure
- Suitable for continuous start/stop applications
- Pumps oil, water, and other fluids
- Stainless steel pump and check valves standard
- Maintains pressure with minimal power consumption (Non-load holding)
- Usable in hazardous areas: per ATEX II, CAT. 2 GDcT5
- Quiet operation
- Can operate on gases other than air
- Simple to install and maintain
- Compact, rugged design
- Only 15psi (1bar) air pressure required to start pump

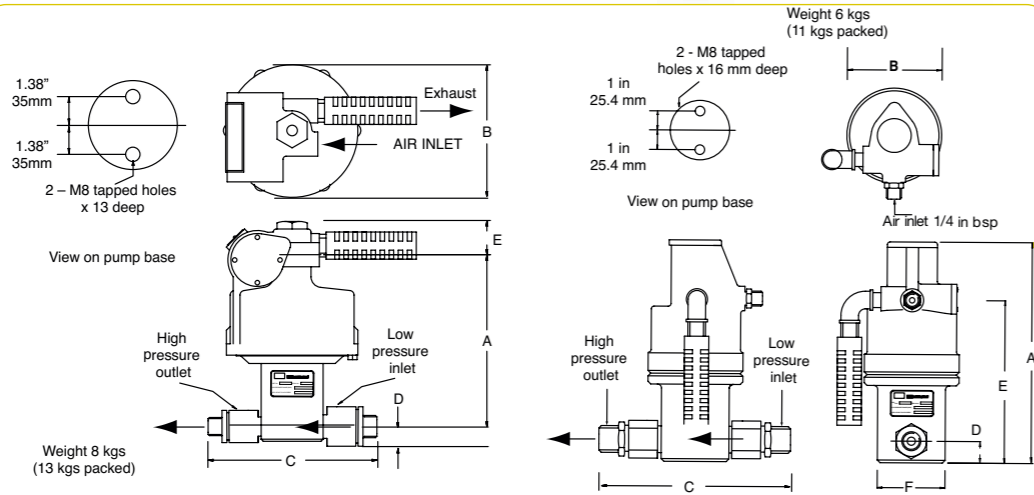

RAM/DIAMETER		RAM/DIAMETER						RAM/DIAMETER	
CAT #	(mm) (in)	A	B	C	D	E	F	CAT #	(mm) (in)
PUA26(B/U)	31.75 1 1/4	in 2.17	4.02	6.61	.87	6.69	2.87	PMA130(B/U)	35 1 3/8
		mm 233	102	168	22.2	170	73		
PUA70(B/U)	19 3/4	in 8.74	4.02	6.61	.87	6.22	2.87	PMA190(B/U)	28.5 1 1/8
		mm 222	102	168	22.2	158	73		
PUA157(B/U)	12.7 1/2	in 8.74	4.02	6.61	.87	6.22	2.87	PMA240(B/U)	25.4 1
		mm 222	102	168	22.2	158	73		
PUA275(B/U)	9.53 3/8	in 8.74	4.02	6.61	.87	6.22	2.87	PMA370(B/U)	20.6 13/16
		mm 222	102	168	22.2	158	73		
PUA430(B/U)	7.94 5/16	in 8.74	4.02	6.61	.87	6.22	2.87	PMA520(B/U)	17.5 11/16
		mm 222	102	168	22.2	158	73		
PUA655(B/U)	6.35 1/4	in 8.74	4.02	6.61	.87	6.22	2.87	PMA770(B/U)	14.3 9/16
		mm 222	102	168	22.2	158	73		
PUA982(B/U)	5.13 .202	in 8.74	4.02	6.61	.87	6.22	2.87	PMA980(B/U)	12.7 1/2
		mm 222	102	168	22.2	158	73		
PMA27(B/U)	76.2 3	in 8.66	7.01	9.06	1.5	1.89		PMA1740(B/U)	9.5 3/8
		mm 220	178	230	38	48			
PMA60(B/U)	50.8 2	in 8.27	7.01	9.06	1.5	1.89		PMA2410(B/U)	8 5/16
		mm 210	178	230	38	48			
PMA90(B/U)	41.3 1 5/8	in 8.27	7.01	9.06	1.5	1.89			
		mm 210	178	230	38	48			

BSP FITTINGS	NPT FITTINGS	RATIO 1:	OUTLET PRESSURE		OUTPUT PER CYCLE		MAXIMUM FLOW AT ZERO PRESSURE		INLET	OUTLET
			(BAR)	(PSI)	(LITRES)	(IN ³)	(LITRES/MIN)	(IN ³ /MIN)		
PUA26B	PUA26U	4.3	26	380	0.028	1.68	14	850	1/2" BSP/NPT	1/2" BSP/NPT
PUA70B	PUA70U	11.9	70	1,010	0.01	0.607	5	305	1/2" BSP/NPT	1/2" BSP/NPT
PUA157B	PUA157U	26.7	157	2,280	0.004	5.269	2.4	146	1/2" BSP/NPT	1/2" BSP/NPT
PUA275B	PUA275U	47.5	275	3,990	0.0025	0.151	1.4	85	1/2" BSP/NPT	1/2" BSP/NPT
PUA430B	PUA430U	68.4	430	6,230	0.0017	0.105	0.9	55	1/2" BSP/NPT	1/2" BSP/NPT
PUA655B	PUA655U	107	655	9,500	0.0011	0.67	0.6	36	1/2" BSP/NPT	1/2" BSP/NPT
PUA982B	PUA982U	163.8	982	14,250	0.0007	0.044	0.4	24	1/2" BSP/NPT	1/2" BSP/NPT
PMA27B	PMA27U	4	27	390	0.16	9.72	37	2260	1" BSP/NPT	3/4" BSP/NPT
PMA60B	PMA60U	9	60	870	0.07	4.32	23	1400	1" BSP/NPT	3/4" BSP/NPT
PMA90B	PMA90U	13.6	90	1,300	0.05	2.85	15	915	1" BSP/NPT	3/4" BSP/NPT
PMA130B	PMA130U	19	130	1,880	0.034	2.04	11	670	3/4" BSP/NPT	1/2" BSP/NPT
PMA190B	PMA190U	28.4	190	2,750	0.023	1.37	7.3	455	3/4" BSP/NPT	1/2" BSP/NPT
PMA240B	PMA240U	36	240	3,480	0.018	1.08	5.8	354	3/4" BSP/NPT	1/2" BSP/NPT
PMA370B	PMA370U	54.5	370	5,360	0.012	0.71	3.8	230	1/2" BSP/NPT	1/2" BSP/NPT
PMA520B	PMA520U	76.5	520	7,540	0.008	.51	2.8	170	1/2" BSP/NPT	1/2" BSP/NPT
PMA770B	PMA770U	113	770	11,160	0.006	0.34	1.8	110	1/2" BSP/NPT	1/2" BSP/NPT
PMA980B	PMA980U	145	980	14,210	0.004	0.27	1.5	91	1/2" BSP/NPT	1/2" BSP/NPT
PMA1740B	PMA1740U	256	1,740	25,230	0.0025	0.15	0.84	51	1/2" BSP/NPT	1/2" HP
PMA2410B	PMA2410U	368	2,410	35,000	0.0017	0.104	0.58	35	1/2" BSP/NPT	1/2" HP

START-UP KITS SK SERIES

10 TON TURNKEY SETS

PUMPS



- 10 Ton Start-Up Kit covers a range of lifting, shifting, and positioning needs
- Broad range of cylinder types and strokes to fit many applications
- Neatly packaged in a durable, molded storage case to securely house your equipment and is ready to use upon opening
- All sets include a t-adaptor (No. 9670) and a complete coupler set (No. 9795)
- SK10TE kit is CE Compliant



Ordering Information Order No.: SK10TE

Kit Contents			
Hand Pump	Usable Oil Cap. cc	Volume Per Stroke Low / High Press. cc	Weight kg
P19L	443	4.1 / 0.9	2.3
Gauge	Type	Primary Units	Face Diameter mm
9040E	analog	bar	63.5
Hose	Length m	Burst Rating	I.D. mm
9754E	1.8	4:1	6.5
Cylinders	Capacity Short Tons	Stroke mm	Collapsed Height mm
C106C	10	155.6	247.7
RSS101	10	38.1	88.9
RH123	12	76.2	184.2
RLS100	10	11.1	44.5
Spreader	Min. Clearance mm	Max Spread mm	Weight kg
HS2000	14.2	101.6	2.2
Case	Material	L x H x W mm	Weight w/o Product kg
2008632	Heavy Duty Plastic	800 x 520 x 292	5.8

Values shown in short tons (2,000 lb). To convert to long tons, multiply by 0.893. To convert to metric tons, multiply by 0.907.



Note: Storage cases are **not included** with the 25 ton startup kits, they must be ordered separately.



START-UP KITS SK SERIES

25 TON TURNKEY SETS

PUMPS

- 25 Ton Start-Up Kit covers a range of lifting, shifting, and positioning needs
- Broad range of cylinder types and strokes to fit many applications
- All sets include a t-adaptor (No. 9670) and a complete coupler set (No. 9795)
- SK25TE kit is CE Compliant

Optional 25 Ton Storage Cases

Power Team offers two different storage boxes to house your SK25T.

Order No.:
MB5

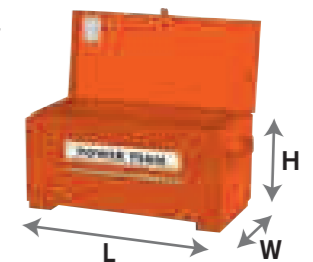

Order No.:
308435OR9



Ordering Information Order No.: SK25TE

Kit Contents			
Hand Pump	Usable Oil Cap. cc	Volume Per Stroke Low / High Press. cc	Weight kg
P59L	1082	12 / 2.6	4.1
Gauge	Type	Primary Units	Face Diameter mm
9040E	analog	bar	63.5
Hose	Length m	Burst Rating	I.D. mm
9754E	1.8	4:1	6.5
Cylinders	Capacity Short Tons	Stroke mm	Collapsed Height mm
C256C	25	158.8	273
RSS302	30	61.9	117.5
RH302	30	63.5	158.8
RLS300	30	12.7	58.7
Spreader	Min. Clearance mm	Max Spread mm	Weight kg
HS2000	14.2	101.6	2.2

Values shown in short tons (2,000 lb). To convert to long tons, multiply by 0.893. To convert to metric tons, multiply by 0.907.

Electric/Battery Pump HYDRAULIC PE10 SERIES

Up to 25 Ton Quarter Horse® Two Speed

High performance in compact package. Electric and battery powered models for powering tools and cylinders up to 25 ton.



PR104
700 bar



The Quarter Horse pump has a maximum operating pressure of 700 bar, which handles a wide variety of hand held hydraulic tools.

PUMPS

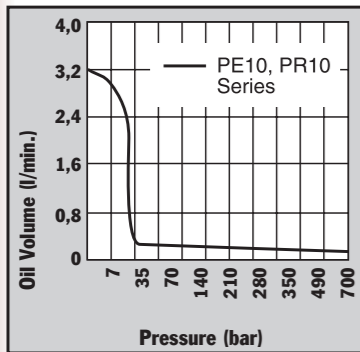

- Portable power source for hydraulic cylinders, and tools.
- Permanent magnet motor starts easily under load, even with reduced voltage conditions.
- Battery-operated models have 2,4 m power cord with alligator clips to connect to any 12 volt battery.
- Optional rechargeable battery pack with shoulder strap for maximum portability.
- Pump typically delivers 15 minutes of continuous operation at 700 bar on a single battery.
- Pump can be operated in any position.
- 24 volt hand and foot switches available for all AC powered models.
- High-impact housing with flame-retardant construction.
- Base mounting holes for fixed installations.

For use with Cyl. Type	Description	Order No.	Valve Type	Valve No.	Valve Function	Control Switch	Motor	Reservoir Usable Cap. (l)
Single-Acting	Base model pump with 0,19 KW motor. Bladder type reservoir, 220 volt power required.	PE102 -E220	2-Way/ Auto. Dump	9561	Advance Return (Auto.)*	Rocker Type off, Momentary on	0,19 KW, 220/230V 50/60 Hz, Single Phase	1
Single-Acting	PE102, except has automatic dump valve.	PE102A -E220	Auto. Dump	9562	Advance* Return**	Rocker Type off, Momentary on	0,19 KW, 220/230V 50/60 Hz, Single Phase	1
Single-Acting/ Double-Acting	Base model pump has 4-way valve for operating double-acting systems. 220 volt power required.	PE104 -E220	4-Way	9563	Advance Hold Return*	Rocker Type off, Momentary on	0,19 KW, 220/230V 50/60 Hz, Single Phase	1
Single-Acting	PE102, except requires 12 volt DC.	PR102	2-Way/ Auto. Dump	9561	Advance Return (Auto.)	Rocker Type off, Momentary on	0,19 KW, 12V†	1
Single-Acting	PE102A, except requires 12 volt DC.	PR102A	Auto. Dump	9562	Advance Return**	Rocker Type off, Momentary on	0,19 KW, 12V†	1
Single-Acting/ Double-Acting	PE104, except requires 12 volt DC.	PR104	4-Way	9563	Advance Hold Return	Rocker Type off, Momentary on	0,19 KW, 12V†	1

* "Advance" position holds pressure with motor shut off. "Return" position advances cylinder with motor running and returns cylinder with motor shut off. Also available in CE / E 110

** Cylinder advances with motor running and automatically returns with motor shut off.
† Comes with an 2,4 m. alligator clip cord for 12 volt DC use.

Accessories



BP212VQ – Optional 12 volt battery pack. Includes sealed lead acid battery, 115V charger, 1,2 m cord, carrying case and shoulder strap. Wt., 8 kg.



RB12V – Battery only.
BP12INT – Battery with cord and carrying case. Wt., 5 kg.
RC12V – Replacement 1,2 m battery cord only. Wt., 0,2 kg.

BC212 – Battery charger for U.S.A. Wt., 3 kg.
BC212EUR – Battery charger for Europe. Wt., 3 kg.
25017 – Remote hand control with 3 m cord. Wt., 0,4 kg.

Max. Pump No.	Pressure Output (bar)	dBa @ Idle and 700 (bar)	Oil Del. (l/min at..)	0 (bar)	700 (bar)	Overall Dimensions (mm)	Prod. Wt. with Oil (kg)
PE10 Series	700	68-74*	1,9	0,16	330 L x 197 W x 203 H	9,1	
PR10 Series							

* Measured at 0,9 m distance, all sides.

NOTE: PR10 rechargeable model is equipped with 2,4 m cord with alligator clips. Order optional battery pack (No. BP212VQ) or use with any 12 volt battery.

NOTE: Amp draw at 700 bar; 6 amp at 115 volt, 3 amp at 230 volt, and 35 amp at 12 volt.



9560 – Pressure regulator. Adjustable from 70 to 700 bar. All mounting hardware included. Wt., 1,4 kg.



251660 – Foot switch with 3 m cord. Single pole, double throw, 15 amp @ 125-250 VAC. Wt., 0,45 kg.

PUMPS



Electric Pump HYDRAULIC PE17 SERIES

Up to 55 Ton
279 cm³/min.
2 Speed

For maintenance and construction applications.

- For use with single-acting or double-acting cylinders at operating pressures to 700 bar.
- For intermittent duty; starts under full load.
- Equipped with 0,37Kw (1/2 hp), 3,450 rpm, single-phase, thermal protected induction motor; 3 m remote control cord (PE172S has 7,6 m cord)
- Low amperage draw; small generators and low amperage circuits can be used as power source.
- Extremely quiet noise level (67-81 dBA).



PE172

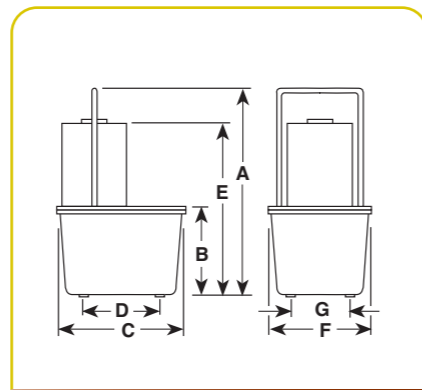
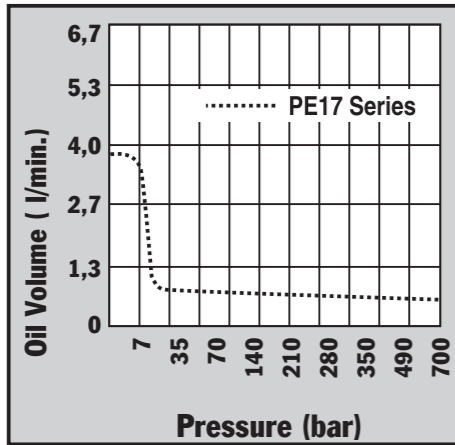

Pump No.	Max. Pressure Output bar	rpm	dBA at Idle and 700 bar	Amp Draw 220 V -		Oil Del. (liters./min. @) †				A (mm)	B (mm)	C (mm)	D (mm)	E (mm)	F (mm)	G (mm)	Prod. Wt. with Oil (kg)
				at 700 bar	at 700 bar	0 bar	7 bar	350 bar	700 bar								
PE17 Series	700	2850	67/81*	5	3,9	2,5	0,3	0,2	470	178	289	181	378	235	130	20,4	
PE17M Series	700	2850	67/81*	5	3,9	2,5	0,3	0,2	460	168	292	-	368	241	-	24,0	

* Measured at 0,9 m distance, all sides.

† Typical delivery. Actual flow will vary with field conditions.



PE172SM



PE172-E220



Description	Order No.	Valve Type	Valve No.	Valve Function	Control Switch ††	Motor	Reservoir Usable (l)
Base model pump with 0,37 KW pump with 7,6 l thermoplastic reservoir.	PE172-50-220	2-Way	9517	Advance Return (Auto+)	Remote Motor Control (3,1m) on/off	0,37 kW, 220 V* 50/60 Hz, Single Phase	4,72
PE172-50-220, except has 9,5 l aluminum reservoir.	PE172M-50-220	2-Way	9517	Advance Return (Auto+)	Remote Motor Control (3,1m) on/off	0,37 kW, 220 V* 50/60 Hz, Single Phase	6
PE172-50-220, except has solenoid operated valve.	PE172S-50-220	3-Way	9570	Advance Hold Return	Remote Motor & Valve (7,6 m)	0,37 kW, 220 V* 50/60 Hz, Single Phase	4,72
PE172S-50-220, except has aluminum reservoir.	PE172SM-50-220	3-Way	9570	Advance Hold Return	Remote Motor & Valve (7,6 m)	0,37 kW, 220 V* 50/60 Hz, Single Phase	6
Best suited for crimping, punching, pressing. Not for lifting. Thermoplastic reservoir.	PE172A-50-2208	Auto./Dump Manifold	45554	Advance Return	Remote Motor Control (3,1 m) on/off	0,37 kW, 220 V* 50/60 Hz, Single Phase	4,72
PE172A, except has aluminum reservoir.	PE172AM-50-2208	Auto./Dump Manifold	45554	Advance Return	Remote Motor Control (3,1 m) on/off	0,37 kW, 220 V* 50/60 Hz, Single Phase	6
0,37 KW pump with 7,6 l thermoplastic reservoir. Meets CE requirements.	PE172-E220	2-Way	9517	Advance Return (Auto+)	Remote Motor Control (3,1 m) on/off	0,37 kW, 220 V* 50 Hz, Single Phase	4,72
PE172-50-220, except has 9,5l aluminium reservoir. Meets CE requirements	PE172M-E220	2-Way	9517	Advance Return (Auto+)	Remote Motor Control (3,1 m) on/off	0,37 kW, 220 V* 50 Hz, Single Phase	6
PE172-50-220, except has solenoid operated valve. Meets CE requirements	PE172S-E220	3-Way	9570	Advance Hold Return	Remote Motor & Valve (3,1m)	0,37 kW, 220 V* 50 Hz, Single Phase	4,72
PE172S-50-220 except has aluminium reservoir. Meets CE requirement	PE172SM-E220	3-Way	9570	Advance Hold Return	Remote Motor & Valve (3,1m)	0,37 kW, 220 V* 50 Hz, Single Phase	6
Best suited for crimping, punching, pressing. Thermoplastic res. Meets CE requirement	PE172A-E220	Auto./Dump Manifold	45554	Advance/Return	Remote Motor Control (3,1 m) on/off	0,37 kW, 220 V* 50 Hz, Single Phase	4,72
PE172A, except has aluminium reservoir. Meets CE requirements	PE172AM-E220	Auto./Dump Manifold	45554	Advance/Return	Remote Motor Control (3,1 m) on/off	0,37 kW, 220 V* 50 Hz, Single Phase	6
PE172-50-220, except has 9500 double-acting valve.	PE174-50-220	4-Way	9500	Advance Hold Return**	Remote Motor Control (3,1 m) on/off	0,37 kW, 220 V* 50/60 Hz, Single Phase	4,72
Same as PE174-50-220, except has aluminium reservoir.	PE174M-50-220	4-Way	9500	Advance Hold Return**	Remote Motor Control (3,1 m) on/off	0,37 kW, 220 V* 50/60 Hz, Single Phase	6
PE172-50-220, except has 9500 double-acting Valve. Meets CE requirements	PE174-E220	4-Way	9500	Advance Hold Return**	Remote Motor Control (3,1 m) on/off	0,37 kW, 220 V* 50 Hz, Single Phase	4,72
Same as PE174-50-220, except has aluminium Reservoir. Meets CE requirements	PE174M-E220	4-Way	9500	Advance Hold Return	Remote Motor Control (3,1 m) on/off	0,37 kW, 220 V* 50 Hz, Single Phase	6

* Available with 115V., 60 Hz motor (to order , remove suffix "50-220" behind pump order number).

** "Advance" position holds pressure with motor shut off.

† "Advance" position holds pressure with motor shut off. "Return" position advances cylinder with motor running and returns cylinder with motor shut off.

∞ Not to be used for lifting.

NOTE: Usable oil is calculated with the oil fill at the recommended maximum level of 38 mm below reservoir cover plate.

‡ Some Power Team pumps are available in special configurations not listed in this catalog. Power Team can "Assemble to Order" pumps with special seals, voltages, valves, relief valve settings, etc. For your special requirements please consult your local distributor or the Power Team factory.

Also available in I C E E 110



Electric Pump HYDRAULIC PE18 SERIES

Up to 55 Ton
295 cm³/min.
Vanguard Jr. Series®

Ideal for use with small hydraulically powered tools.

- Vanguard Jr.® pumps provide two-speed high performance in a light-weight, compact package.
- Gauge port provided on pump. Metal reservoir on all models.
- Equipped with a 0,37Kw (1/2 hp), 220 volt, 50 Hz single phase motor that starts under load, even at reduced voltage.
- Low amperage draw permits use with smaller generators and low amperage circuits.
- All pumps have a 3 m remote control (PE183C has 7,6 m remote control).
- CSA rated for intermittent duty. Noise level of 85-90 dBA.



PE182

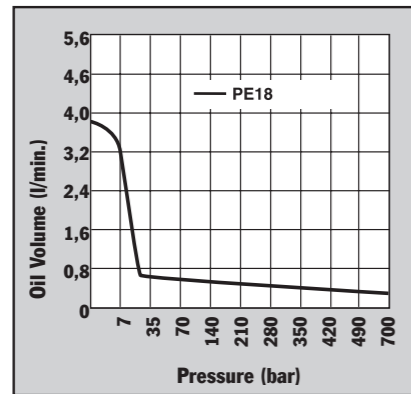

For operating hydraulic crimping, cutting or other tools:

- **No. PE183C** - For crimping or pressing applications. Has special electrical circuitry to pulse/advance, hold at full pressure, build to a predetermined pressure, release and reset circuit. Features separate emergency return switch.
- **No. PE184C** - Allows you to alternately operate a spring-return cutting and/or crimping tool without disconnecting either tool. Select port connection with manual 4-way valve, start pump with remote control hand switch and extend connected tool. When hand switch is switched to off, pump stops and automatic valve opens, allowing tool to return. In center (neutral) position, manual control valve holds tool in position at time valve is shifted.

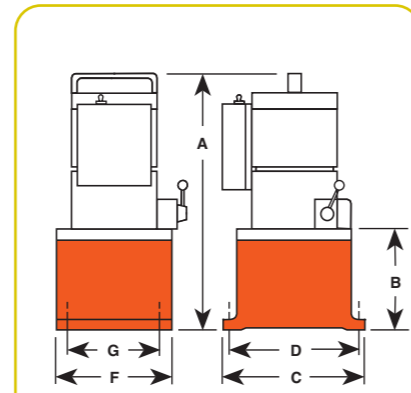

700 bar
LR19814

Pump No.	Max. Pressure Output bar	rpm	dBA at Idle and 700 bar	Amp Draw 220 V at 700 bar	Oil Del. (liters./min. @) †				A (mm)	B (mm)	C (mm)	D (mm)	E (mm)	F (mm)	G (mm)	Prod. Wt. with Oil (kg)
					0 bar	7 bar	350 bar	700 bar								
PE182	700	12.000	85/90**	4,5 Amp.	3,7	3,0	0,4	0,3	406	121	203	181	152	130	13,6	
PE183	700	12.000	85/90**	4,5 Amp.	3,7	3,0	0,4	0,3	406	121	203	181	152	130	13,6	
PE183A	700	12.000	85/90**	4,5 Amp.	3,7	3,0	0,4	0,3	406	121	203	181	152	130	13,6	
PE184	700	12.000	85/90**	4,5 Amp.	3,7	3,0	0,4	0,3	406	121	203	181	152	130	13,6	
PE183-2*	700	12.000	85/90**	4,5 Amp.	3,7	3,0	0,4	0,3	470	184	292	254	241	203	19,0	
PE184-2*	700	12.000	85/90**	4,5 Amp.	3,7	3,0	0,4	0,3	470	184	292	254	241	203	19,0	
PE183C ††	700	12.000	85/90**	4,5 Amp.	3,7	3,0	0,4	0,3	406	121	203	181	152	130	13,6	
PE184C ††	700	12.000	85/90**	4,5 Amp.	3,7	3,0	0,4	0,3	406	121	203	181	152	130	13,6	

* 9,5 l reservoir.
** Measured at 0,9 m distance, all sides.

† Typical delivery. Actual flow will vary with field conditions.
†† Special application pumps for cutting, crimping or pressing.



PE183-2



PE183C

For use with cyl. type	Description	Order No.	Valve Type	Valve Function	Control Switch	Motor	Reservoir Usable (l)
Single-acting	Base model pump has 0,37 KW pump with 2-Way valve and 1,9 l reservoir.	PE182-50-220	2-Way	Advance Return†	Remote Motor Control (3,1 m) on/off	0,37 kW, 220 V** 50 Hz, A.C., Single Phase	1,7
Single-acting	PE182-50-220, except has 3-way valve.	PE183-50-220	3-Way	Advance Hold Return	Remote Motor Control (3,1 m) on/off	0,37 kW, 220 V** 50 Hz, A.C., Single Phase	1,7
Single-acting	PE183-50-220, except has 9,5 l reservoir.	PE183-2-50-220	3-Way	Advance Hold Return	Remote Control (3,1 m)	0,37 kW, 220 V** 50 Hz, A.C., Single Phase	8,4††
Single-acting	PE183-50-220, except has "dump valve".	PE183A-50-220∞	Auto./Dump Pump	Advance Return	Remote (3,1 m)	0,37 kW, 220 V** 50 Hz, A.C., Single Phase	1,7
Single-acting	Special crimping pump. See details on page 84.	PE183C-50-220∞	Special, for crimping only	Advance Hold Return	Remote Motor Control (7,6 m) on/off	0,37 kW, 220 V** 50 Hz, A.C., Single Phase	1,7
Single-acting/ double-acting	Base model pump has 0,37 KW pump for double-acting systems with 1,9 l reservoir.	PE184-50-220	4-Way	Advance Hold Return†	Remote Motor Control (3,1 m) on/off	0,37 kW, 220 V** 50 Hz, A.C., Single Phase	1,7
Single-acting/ double-acting	PE184, except with 9,5 l reservoir.	PE184-2-50-220	4-Way	Advance Hold Return†	Remote Motor Control (3,1 m) on/off	0,37 kW, 220 V** 50 Hz, A.C., Single Phase	8,4††
Single-acting/ double-acting	Special crimping pump. See details on page 84.	PE184C-50-220*	4-Way	Advance Return	Remote Control (3,1 m) on/off	0,37 kW, 220 V** 50 Hz, A.C., Single Phase	1,7

* Also for use with special single-acting cylinder applications.
** Available with 115 Volt, 50 Hz motor (to order, remove suffix "50-220" behind pump order number). Specify voltage when ordering.

† Holds when motor is shut off and valve is in "advance" position.
†† Pumps supplied with 7,6 l oil (usable oil is 5,7 l), will hold 9,5 l when filled to within 13 mm below reservoir cover plate.
∞ Not to be used for lifting.



Electric Pump

PE21 SERIES

Up to 75 Ton
361 cm³/min.
Two-Speed

Low-speed, high-torque for heavy-duty, extended-cycle operations.

PUMPS

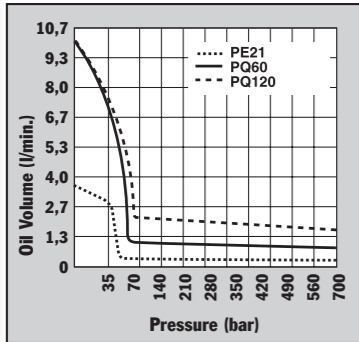

- Totally enclosed, fan cooled induction motor: 0,75Kw (1 hp), 1,725 rpm, 60 Hz, single phase. Thermal overload protection.
- Remote control, with 3,1 m cord is standard on pumps with solenoid valves. Manual valve pumps have "Stop", "Start" and "Run/Off/Pulse" switches. Pump controls are moisture and dust resistant.
- Motor drip cover with carrying handles and lifting lug.
- Low noise level of 70 dBA[®] 700 bar.
- In the event of electrical interruption, pump shuts off and will not start up until operator presses the pump start button.
- 24 volt control circuits on units with remote controls provide additional user/operator safety.



PUMPS



PE21 series pump and RD5513 cylinder used in a special press that produces pharmaceutical-grade extracts for herbal medicines.

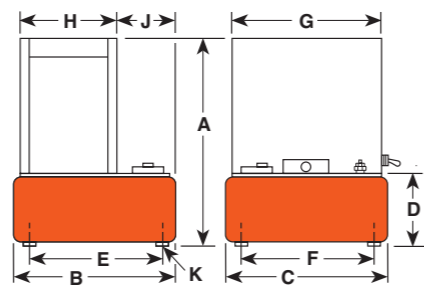

Pump No.	Max. Pressure Output		dBA at Idle and 700 bar	Oil Del. (l/min. at.)				Dimensions							Prod. Wt. w/Oil (kg)			
	bar	rpm		7 bar	70 bar	350 bar	700 bar	A (mm)	B (mm)	C (mm)	D (mm)	E (mm)	F (mm)	G (mm)		H (mm)	J (mm)	K*** (in)
PE21 Series	700	1.437	70*	3,6	0,4	0,4	0,3	543	292	241	165	254	203	359	241	82,6	1/2-20 UNF	44,4†

* Measured at a 0,9 m distance, all sides.

*** For 50,8 mm dia. swivel casters, order (4) No. 10494.

† Shipping weight with manual valve; add 6,4 kg for pump with solenoid valve.

For use with cyl.-type	Description	Order No.	Valve Type	Valve No.	Valve Function	Max. Amp Draw at 700 bar	Motor	Reservoir Usable (l)
Single-acting	0,75 KW pump with 9,5 l Reservoir and manual valve.	PE213-50-220	3-Way	9520*	Advance Hold Return	230 V - 7,5 amps	0,75 KW, 220 Volt 50 Hz, Single Phase	9,4
Single-acting	PE213, except has solenoid operated remote valve.	PE213S-50-220	3-Way	9599†	Advance Hold Return	230 V - 7,5 amps	0,75 KW, 220 Volt 50 Hz, Single Phase	9,4
Double-acting	0,75 KW pump with 9,5 l Reservoir and manual valve.	PE214-50-220	4-Way	9506*	Advance Hold Return	230 V - 7,5 amps	0,75 KW, 220 Volt 50 Hz, Single Phase	9,4
Double-acting	PE214, except has solenoid operated remote valve.	PE214S-50-220	4-Way	9512†	Advance Hold Return	230 V - 7,5 amps	0,75 KW, 220 Volt 50 Hz, Single Phase	9,4

* Manual valve. Pump is equipped with RUN/OFF/PULSE switch for control of motor.

† Solenoid valve. Pump is equipped with a remote control switch with 3,1 m cord.



Electric Pump HYDRAULIC PED SERIES

**410 cm³/min.
Two-Speed**

Ideal for running multiple tools or cylinders from one power unit. Recommended for cylinders up to 75 tons.

PUMPS

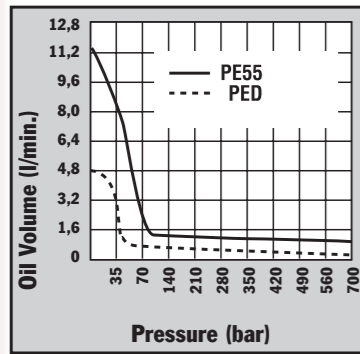

- Two-speed pumps have the same low pressure and high pressure flows from both valves.
- Flows and pressures of each pump are independent.
- Delivers 4,8 l/min. of oil at 7 and 0,4 l/min. at 700 bar from each pump.
- 1,12 KW, 220 volt, 50 Hz induction motor, 3,1 m remote control and 19 l steel reservoir.
- Models available for operating single-acting or double-acting cylinders.
- Each power unit contains two separate pumps and two separate valves allowing operator to control multiple processes with one power unit.
- Both pumps on each power unit are equipped with an externally adjustable pressure relief valve.
- Not recommended for frequent starting and stopping.



PED253



PED254



PED254S

PUMPS

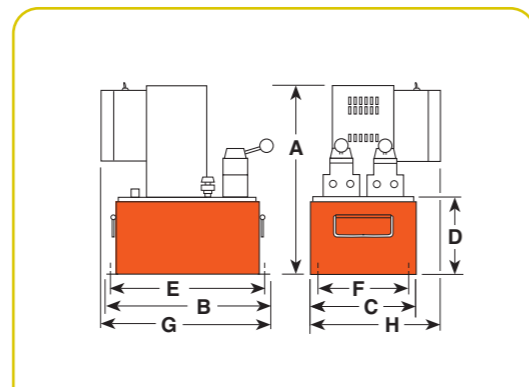

Pump No.	Max. Pressure Output bar	rpm	dBA at Idle and 700 bar	(220 V)** Amp Draw At 700 bar	Oil Del. (l/min at..)				A (mm)	B (mm)	C (mm)	D (mm)	E (mm)	F (mm)	G (mm)	H (mm)	Prod. Wt. w/Oil (kg)
					7 bar	50 bar	350 bar	700 bar									
PED-Series	700	2.874	87/85*	11	4,8	0,6	0,6	0,4	527	457	292	216	419	229	457	330	77

* Noise level reading (dBA) measured at a 0,9 m distance, all sides.

** Amp draw at 700 bar, 230 Volts 50 Hz is 15 Amps.

For use with cyl.-type	Description	Order No.	Valve Type	Valve No.	Valve Function	Control Switch ††	Motor	Reservoir Usable (l)
Single-acting	1,12 KW pump with 19 l reservoir. Valve has "Posi-Check" feature.	PED253-50-220	3-Way	9520	Advance Hold Return	Remote Motor	1,12 KW, 220 VAC 50 Hz††, Single Phase	16
Double-acting	1,12 KW pump with 19 l reservoir. Valve has "Posi-Check" feature.	PED254-50-220	4-Way	9506	Advance Hold Return	Remote Motor	1,12 KW, 220 VAC 50 Hz††, Single Phase	16
Double-acting	PED254, except has solenoid operated remote valve.	PED254S-50-220	4-Way	9513	Advance Hold Return	Remote Valve	1,12 KW, 220 VAC 50 Hz††, Single Phase	16

†† Control switch wired with line voltage. All remotes are 3,1 m long.



Electric Pump HYDRAULIC PE30 SERIES

0,48 l/min.
Two-Speed
Vanguard® Series

Ideal for maintenance and construction applications

PUMPS

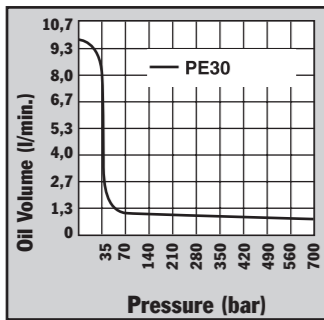

PE302

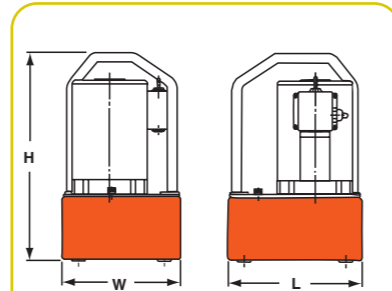

Pump No.	Max Pressure Output bar	Noise level at 700 bar (dBA)	Amp. Draw 220V at 700 bar (A)	Oil Del. (l/min at..)					Overall Dimensions (mm)	Prod. Wt. With Oil (kg)
				7 bar	35 bar	70 bar	350 bar	700 bar		
PE30 Series with 4,7 l res.	700	87/82	7	4,8	3,2	0,7	0,6	0,5	254L x 229W x 406H	18,6
PE30 Series with 7,6 l res.	700	87/82	7	4,8	3,2	0,7	0,6	0,5	343L x 241W x 419H	22,2

- Deliver a powerful punch to operate single-acting or double-acting cylinders.
- Integral roll cage protects pump from abuse.
- 0,75Kw (1 hp), single phase, permanent magnet motor.
- High performance to weight ratio.
- Starts under full load even when voltage is reduced to 50% of nominal rating.
- Quiet operation: 87 dBA @ 700 bar and 82 dBA @ 0 bar. CSA rated for intermittent duty.
- Remote controls and/or solenoid valves feature 24 volt controls.

PE30TWP
Torque Wrench
Applications
See page 171



700 bar



For use with Usable	Order	Valve	Valve	Valve	Control	Reservoir Motor
Single-act. Base model 0,75 KW pump with 4,7 l Reservoir & 2 position valve.	PE302-220^{oo}	3-Way, 2 Pos.	9584	Advance Return	On/Off/ Pulse Switch	0,75 KW 220/230 VAC, 50 Hz, Single Phase 4,5**
Single-act. PE302-220, except has 6,6 l reservoir.	PE302-2-220	3-Way, 2 Pos.	9584	Advance Return	On/Off/ Pulse Switch	0,75 KW 220/230 VAC, 50 Hz, Single Phase 6,1***
Single-act. PE302-220, except has remote motor control.	PE302R-220	3-Way, 2 Pos.	9584	Advance Return	Remote Motor Control (3,1 m)	0,75 KW 220/230 VAC, 50 Hz, Single Phase 4,5**
Single-act. PE302R-220, except has 6,6 l reservoir.	PE302R-2-220	3-Way, 2 Pos.	9584	Advance Return	Remote Motor Control (3,1 m)	0,75 KW 220/230 VAC, 50 Hz, Single Phase 6,1***
Single-act. PE302R-220, except also has solenoid operated remote valve.	PE302S-220†	3-Way, 2 Pos.	9570	Advance Return	Remote Motor Control (3,1 m)	0,75 KW 220/230 VAC, 50 Hz, Single Phase 4,5**
Single-act. PE302S-220, except has 6,6 l reservoir.	PE302S-2-220†	3-Way, 2 Pos.	9570	Advance Return	Remote Motor Control (3,1 m)	0,75 KW 220/230 VAC, 50 Hz, Single Phase 6,1***
Single-act. PE302-220, except has "Auto Dump" valve	PE302A-220	Auto Dump	9610	Automatic Pilot Operation	Remote Motor Control (3,1 m)	0,75 KW 220/230 VAC, 50 Hz, Single Phase 4,5**
Single-act. Base model 0,75 KW pump with 4,7 l Reservoir & 3 position valve.	PE303-220	3-Way, 3 Pos.	9520*	Advance Hold Return	On/Off/ Pulse Switch	0,75 KW 220/230 VAC, 50 Hz, Single Phase 4,5**
Single-act. PE303-220, except has 6,6 l reservoir.	PE303-2-220	3-Way, 3 Pos.	9520*	Advance Hold Return	On/Off/ Pulse Switch	0,75 KW 220/230 VAC, 50 Hz, Single Phase 6,1***
Single-act. PE303-220, except has remote motor control.	PE303R-220	3-Way, 3 Pos.	9520*	Advance Hold Return	Remote Motor Control (3,1 m)	0,75 KW 220/230 VAC, 50 Hz, Single Phase 4,5**
Single-act. PE303R, except has 6,6 l reservoir.	PE303R-2-220	3-Way, 3 Pos.	9520*	Advance Hold Return	Remote Motor Control (3,1 m)	0,75 KW 220/230 VAC, 50 Hz, Single Phase 6,1***
Double-act. Base model 0,75 KW pump with 4,7 l Reservoir & 4-way valve for double-acting systems	PE304-220	4-Way, 3 Pos. Tandem Ctr.	9506*	Advance Hold Return	On/Off/ Pulse Switch	0,75 KW 220/230 VAC, 50 Hz, Single Phase 4,5**
Double-act. PE304-220, except has 6,6 l reservoir.	PE304-2-220	4-Way, 3 Pos. Tandem Ctr.	9506*	Advance Hold Return	On/Off/ Pulse Switch	0,75 KW 220/230 VAC, 50 Hz, Single Phase 6,1***
Double-act. PE304-220, except has remote motor control.	PE304R-220	4-Way, 3 Pos. Tandem Ctr.	9506*	Advance Hold Return	Remote Motor Control (3,1 m)	0,75 KW 220/230 VAC, 50 Hz, Single Phase 4,5**
Double-act. PE304R-220, except has 6,6 l reservoir.	PE304R-2-220	4-Way, 3 Pos. Tandem Ctr.	9506*	Advance Hold Return	Remote Motor Control (3,1 m)	0,75 KW 220/230 VAC, 50 Hz, Single Phase 6,1***

* "Posi-Check®" valve design, "Posi-Check®" guards against pressure loss when valve is shifted from "advance" to "hold" position.

** Shipped with 3,8 l of oil (3,4 l usable).

*** Shipped with 7,6 l of oil.

∞ Not to be used for lifting. Best suited for crimping, pressing & punching applications.



PUMPS

Electric Pump HYDRAULIC PE46 SERIES

0,6 l/min
Two-speed

Best suited for under the roof maintenance and production applications.

PUMPS

- Two-speed high performance pump.
- For use with single- or double-acting cylinders at operating pressures to 700 bar.
- Equipped with a 1.12 KW, 2.875 rpm single-phase, 50 Hz thermal protected induction motor that starts under full load. Noise level of 77-81 dBA.
- All equipped with a 3,1 m remote control except PE462S which has a 7,6 m remote control.
- 24 volt control circuit on all units with remote control.
- CSA rated for intermittent duty.



PE462A

700 bar



PE462S



PE464-E220



PUMPS

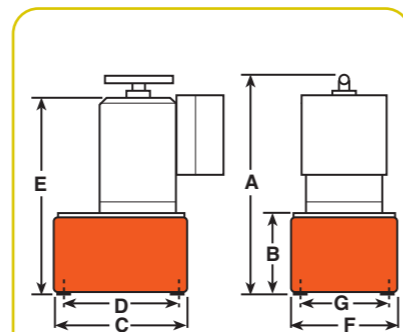
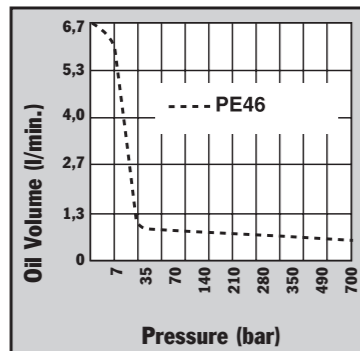

Pump No.	Max. Pressure Output bar	rpm	Noise level at Idle and 700 bar (dBA)	Amp Draw 220 V - at 700 bar (A)		Oil Del. (l/min. at.)†				A (mm)	B (mm)	C (mm)	D (mm)	E (mm)	F (mm)	G (mm)	Prod. Wt. w/Oil (kg)
				0 bar	7 bar	350 bar	700 bar										
PE46-Series	700	2.875	77/81	13	6,7	6,0	0,7	0,6	499	173	292	254	378	241	203	35,8	
PE46-E220	700	2.875	77/81*	13	6,7	6,0	0,7	0,6	499	173	292	254	378	241	203	41,3	

* Measured at 0,9 m distance, all sides.
† Typical delivery. Actual flow will vary with field conditions.

For use with cyl.-type	Description	Order No.	Valve Type	Valve No.	Valve Function	Control Switch†††	Motor	Reservoir Usable*** (l)
Single-acting	Base model 1,12 KW pump with 9,5 l metal reservoir.	PE462-50-220	3-Way	9584	Advance Return†	Remote Motor Control (3,1 m) on/off	1,12 KW, 220 VAC* 50 Hz, Single Phase	9,4
Single-acting	PE462-50-220, except has solenoid valve.	PE462S-50-220	3-Way	9570	Advance Return**	Remote Motor Control (7,6 m) alve	1,12 KW, 220 VAC* 50 Hz, Single Phase	9,4
Single-acting	PE462-50-220, except has "dump valve"	PE462A-50-220∞	Auto/Dump 3-Way	9610	Advance Return	Remote Motor Control (3,1 m) on/off	1,12 KW, 220 VAC* 50 Hz, Single Phase	9,4
Single-acting	1,12 KW pump with 9,5l metal reservoir. Meets C E requirement	PE462-E220	3-Way	9584	Advance Return +	Remote Motor Control (3,1 m) on/off	1,12 KW, 220 VAC* 50 Hz, Single Phase	9,4
Single-acting	PE462-50-220, except has solenoid valve. Meets C E requirement	PE462S-E220	3-Way	9570	Advance Return**	Remote Motor/Valve (7,6 m)	1,12 KW, 220 VAC* 50 Hz, Single Phase	9,4
Single-acting	PE462-50-220, Except has "dump valve". Meets C E requirement	PE462A-E220∞	Auto/Dump 3-Way	9610	Advance Return	Remote Motor Control (3,1 m) on/off	1,12 KW, 220 VAC* 50 Hz, Single Phase	9,4
Double-acting/ multi-single-act.	PE462-50-220, except has 9500 double-acting valve.	PE464-50-220	4-Way	9500	Advance Hold Return†	Remote Motor Control (3,1 m) on/off	1,12 KW, 220 VAC* 50 Hz, Single Phase	9,4
Double-acting/ multi-single-act.	Same as PE464-50-220 Meets C E requirement	PE464-E220	4-Way	9500	Advance Hold Return +	Remote Motor Control (3,1 m) on/off	1,12 KW, 220 VAC* 50 Hz, Single Phase	9,4
Double-acting/ multi-single-act.	Same as PE464S-50-220 Meets C E requirement	PE464S-E220	3/4-Way	9552	Advance Return**	Remote Motor/Valve (3,1m)	1,12 KW, 220 VAC* 50 Hz, Single Phase	9,4
Double-acting/ multi-single-act.	PE462S-50-220, except has 9592 double-acting valve.	PE464S-50-220	3/4-Way	9552	Advance Return**	Remote Motor/Valve (3,1m)	1,12 KW, 220 VAC* 50 Hz, Single Phase	9,4

* Available with 115 V., 60 Hz motor (to order, remove suffix "50-220" behind pump order number). Specify voltage when ordering.
† "Advance" position holds pressure with motor shut off. "Return" position returns cylinder.
††† The remote motor control switch on PE46 series pumps is 24 volt.
** "Advance" position holds pressure with motor shut off.
*** Usable oil is calculated with the oil fill at the recommended level of 13 mm below reservoir cover plate.
∞ Not to be used for lifting. When pump is shut off, oil returns to reservoir.



Electric Pump HYDRAULIC PE55 VANGUARD®

0,9 l/min
For cylinders up to
200 tons.

Heavy duty multiple-applications pump. Heavy construction and concrete stressing. Low voltage starting possible.

PUMPS

- 0,48Kw, 12,000 rpm, 220 volt, 50 Hz universal motor; draws 25 amps at full load, starts at reduced voltage. CSA rated for intermittent duty.
- 3,1 m remote motor control (except PE552S which has a 7,6 m remote motor and valve control).
- True unloading valve achieves greater pump efficiency, allowing higher flows at maximum pressure.
- Reservoirs available in sizes up to 38 l. See accessories page 119.
- Light weight and portable. Best weight to performance ratio of all Power Team pumps.
- “Assemble to Order” System: There are times when a custom pump is required. Power Team’s “Assemble to Order” system allows you to choose from a wide range of pre-engineered, off-the-shelf components to build a customized pump to fit specific requirements. By selecting standard components you get a “customized” pump without “customized” prices. All pumps come fully assembled, less oil and ready for work. See pages 112-115.

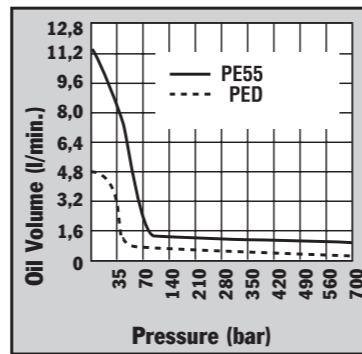

PE55TWP
Torque
Wrench
Applications
See page 172.



PE554W
The new pump;
weather-resistant.

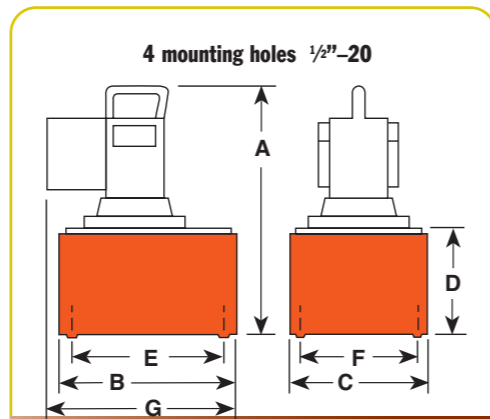

Pump No.	Max. Pressure Output bar	rpm	Noise level Idle and at 700 bar (dBA)	Amp Draw at 700 bar (220 V)** (A)	Oil Del. (l/min at...)				w/Oil (kg)			
					0 bar	50 bar	350 bar	700 bar				
PE55-Series	700	12,000	90/89*	13	11,3	7,1	1,2	0,9				
PE55-E220					A (mm)	B (mm)	C (mm)	D (mm)	E (mm)	F (mm)	G (mm)	
					464	292	241	178	254	203	356	29,4
					520					391		

*Noise level reading (dBA) measured at a 0,9 m distance, all sides.

** Amp draw at 700 bar, 230 Volts 60 Hz is 15 Amps.



For use with cyl.-type	Description	Order No.***	Reservoir		Valve Function	Control Switch ††	Usable (l)
			Valve Type	Valve No.			
Single-acting	Base model 0,84 KW pump with 9,5 l reservoir, remote motor control & 3-way valve.	PE552-50-220	3-Way	9582	Advance Return**	Remote Motor	0,84 KW*, 220 VAC 50Hz, Single Phase
Single-acting	PE552-50-220, except also has solenoid operated remote valve.	PE552S-50-220	3-Way	9570	Advance Hold Return	Remote Motor & Valve	0,84 KW*, 220 VAC 50Hz, Single Phase
Single-acting	PE552-50-220, except has "Auto Dump" valve.	PE552A-50-220	Auto/Dump	9610	Advance Return	Remote Motor	0,84 KW*, 220 VAC 50Hz, Single Phase
Single-acting	0,84 KW pump with 9,5 l reservoir. Valve has "Posi-check" feature.	PE553-50-220	3-Way†	9520	Advance Hold Return	Remote Motor	0,84 KW*, 220 VAC 50Hz, Single Phase
Single-acting	Same as PE552-50-220, but meets also CE requirement	PE552-E220	3-Way	9584	Advance Return**	Remote Motor	0,84 KW*, 220 VAC 50Hz, Single Phase
Single-acting	Same as PE552S-50-220, but meets also CE requirement	PE552S-E220	3-Way	9570	Advance Return	Remote Motor & Valve	0,84 KW*, 220 VAC 50Hz, Single Phase
Single-acting	Same as PE552A-50-220, but meets also CE requirements	PE552A-E220	Auto/Dump	9610	Advance Hold Return	Remote Motor	0,84 KW*, 220 VAC 50Hz, Single Phase
Single-acting	Same as PE553-50-220 but needs also CE Requirement	PE553-E220	3-Way	9520	Advance Hold Return	Remote Motor	0,84 KW*, 220 VAC 50Hz, Single Phase
Double-acting	Base model 0,84 KW pump with 9,5 l res. and 4-way valve for double-acting systems.	PE554-50-220	4-Way†	9506	Advance Hold Return	Remote Motor	0,84 KW*, 220 VAC 50Hz, Single Phase
Double-acting	Same as PE554-50-220 but needs also CE Requirement	PE554-E220	4-Way†	9506	Advance Hold Return	Remote Motor	0,84 KW*, 220 VAC 50Hz, Single Phase
Double-acting	PE554-50-220, except has 9500 tandem center valve.	PE554T-50-220	4-Way	9500	Advance Hold Return	Remote Motor	0,84 KW*, 220 VAC 50Hz, Single Phase
Double-acting	For use with single-acting Spring Seat, Stressing Jack or double-acting cylinder.	PE554P-50-220	4-Way	9500	Advance Hold Return	Remote Motor	0,84 KW*, 220 VAC 50Hz, Single Phase
Double-acting	For use with single- or double-acting Power Seat, Stressing Jacks ONLY.	PE554PT-50-220	4-Way	9628	Advance Hold Sequenced Return	Remote Motor	0,84 KW*, 220 VAC 50Hz, Single Phase
Double-acting	Pump suitable to run multiple spring return tools	PE554C-50-220	4-Way	9511†††	Advance Hold Return	Remote Motor	0,84 KW*, 220 VAC 50Hz, Single Phase
Double-acting	Pump equipped with 3/4-way solenoid valve.	PE554S-50-220	3/4-Way	9552	Advance Hold Return	Remote Motor & Valve	0,84 KW*, 220 VAC 50Hz, Single Phase
Double-acting	Pump suitable to run multiple Spring return cylinder	PE554C-E220	4-Way	9511+++	Advance Hold Return	Remote Motor	0,84 KW*, 220 VAC 50Hz, Single Phase
Double-acting	Pump equipped with 3/4-way solenoid valve	PE554S-E220	3/4-Way	9552	Advance Hold Return	Remote Motor & Valve	0,84 KW*, 220 VAC 50Hz, Single Phase

* Pumps available with 115 volt, 50 Hz motors. (to order remove the -50-220 suffix from the order code). See "Assemble to Order" pump options on pages 102-105.
 ** Holds with motor shut off.
 *** To order PE55 series pumps with CSA approval, add "-C" to the Order No.
 † Valves have "Posi-Check®" feature.

††† Valving allows alternate and independent operation of two different spring return tools. Valve holds pressure only while valve is in "A" or "B" port position with pump motor shut off.
 ∞ Not to be used for lifting.

Also available in E 110 CE



Electric Pump HYDRAULIC PE60 SERIES

Post Tensioning 0,9 l/min Two-Speed

Compact, light weight pump.
Excellent choice for rugged
applications and low voltage
starting.

PUMPS

- Long, trouble free life in the most demanding work environments. For operating single- or double-acting cylinders, or stressing jacks.
- Powered by 0,84 KW, 220 volt, 60/50 Hz single phase motor. Starts under load, even at the reduced voltages at construction sites.
- Optional fan-driven external oil cooler includes rollover guard.
- Insulated carrying handle.
- Integral 102 mm fluid-filled pressure gauge with steel bezel complies with ASME B40.1 Grade A. With 0 to 700 bar pressure range in 7 bar increments.
- Sealed 4,34 l (usable) reservoir. Reservoir drain port is standard.
- Standard oil level sight gauge for accurate oil level monitoring.



PE604T
w/cooler

- External spin-on filter removes contaminants from circulating oil to maximize pump, valve and cylinder/tool life.



PE604T

700 bar



PUMPS

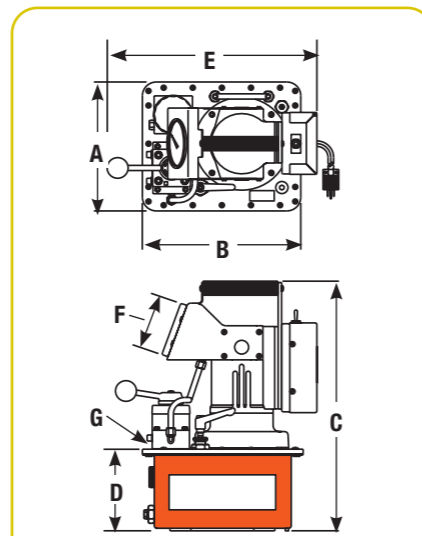
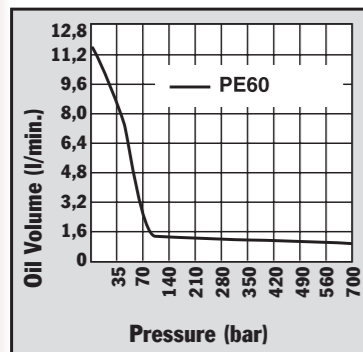

Pump No.	Max. Pressure Output bar	rpm	Noise level Idle and 700 bar (dBA)	Amp Draw at 700 bar (A)	Oil Del. (l/min at..)				A (mm)	B (mm)	C (mm)	D (mm)	E (mm)	F (mm)	G (in)	Prod. Wt. w/Oil (kg)
					0 bar	50 (50)	350 bar	700 bar								
PE604T -220	700	12.000	80/85	13	11,3	7,1	1,2	0,9	263,5	301,6	457,2	152,4	381	101,6	3/8 NPTF	27,2
PE604PT -220	700	12.000	80/85	13	11,3	7,1	1,2	0,9	263,5	301,6	457,2	152,4	381	101,6	3/8 NPTF	27,7

NOTE: Unloading pressure is 70 bar.
Consult factory for PE60 pump models with other control and valve options.



The PE60 used for pre-stressing.



Description	Order No.	Valve Type	Valve No.	Valve Function	Control Switch	Motor	Reservoir Usable (l)
Single-Acting, Spring Seat, Stressing Jack or Double-Acting	PE604T	4-Way 3-position	9500	Advance Hold Return	On/Off/Pulse	0,84 kW, 220 VAC 50 Hz, Single Phase	4,34
Single-Acting or Double-Acting Power Seat, Stressing Jacks Only	PE604PT	4-Way 3-position	9628 Model C	Advance Hold Sequenced Return	On/Off/Pulse	0,84 kW, 220 VAC 50 Hz, Single Phase	4,34

OPTIONAL

252511: Oil cooler kit for PE604T or PE604PT, 115 VAC. Weight 2,7 kg. **252512:** Oil cooler kit for PE604T or PE604PT, 220 VAC. Weight 2,7 kg.



Electric Pump HYDRAULIC PQ60 SERIES

Up to 200 ton
0,8 l/min

Pump designed specifically for heavy duty, extended cycle operation.

- For operating single- or double-acting cylinders.
- Metal shroud keeps dirt and moisture out of motor and electrical components.
- Electrical shut-down feature prevents unintentional restarting of motor following an electrical service interruption.
- Internal relief valve limits pressure to 700 bar. External relief valve is adjustable from 70 to 700 bar.
- Pumps operate below maximum OSHA noise limitation (74-76 dBA).
- Start and operate under full load, even with voltage reduced 10%.



PQ603

700 bar

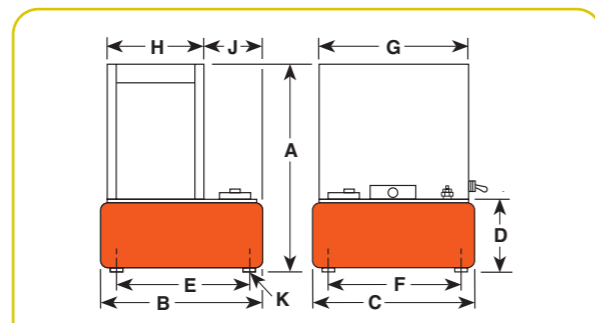
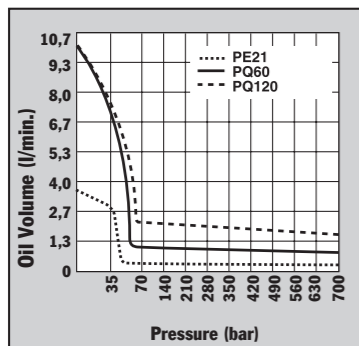

Pump No.	Max. Pressure Output bar	Oil Del. (l/min at...)	Noise level at Idle and 700 bar (dBA)	Amp Draw at 700 bar (A)	Oil Del. (l/min at...)				Dimensions					Prod. Wt. w/Oil (kg)					
					7 bar	70 bar	350 bar	700 bar	A (mm)	B (mm)	C (mm)	D (mm)	E (mm)		F (mm)	G (mm)	H (mm)	J (mm)	K*** (in)
PQ60 Series	700	0,8	74/76* (following page)	See Chart	9,7	0,9	0,9	0,8	638	362	394	184	308	338	373	237	122,2	1/2-20 UNF	76,6**

* Measured at a 0,9 m distance, all sides.
 ** Total weight with oil and 3-way solenoid valve. Subtract 4,5 kg to obtain weight of pump with manual valve.

*** For 50,8 mm dia. swivel casters, order (4) No. 10494.



PQ604



Hydraulic Machine Press Operation.



PQ604S

For use with Cyl. Type	Description	Order No.	Valve Type	Valve No.	Valve Function	Max. Amp Draw at 700 bar (A)	Motor	Reservoir Usable (l)
Single-Acting	1,49 KW pump with 21,6 l reservoir and manual valve.	PQ603-50-220	3-Way	9520*	Advance Hold Return	115V - 22 amps 230V - 11 amps	1,49 KW, 220 Volt 50 Hz, Single	20
Single-Acting	PQ603-50-220, except has solenoid operated remote valve.	PQ603S-50-220	3-Way	9599†	Advance Hold Return	115V - 22 amps 230V - 11 amps	1,49 KW, 220 Volt 50 Hz, Single	20
Double-Acting	1,49 KW pump with 21,6 l reservoir and manual valve.	PQ604-50-220	4-Way	9506*	Advance Hold Return	115V - 22 amps 230V - 11 amps	1,49 KW, 220 Volt 50 Hz, Single	20
Double-Acting	PQ604-50-220, except has solenoid operated remote valve.	PQ604S-50-220	4-Way	9512†	Advance Hold Return	115V - 22 amps 230V - 11 amps	1,49 KW, 220 Volt 50 Hz, Single	20

* Manual valve. Pump is equipped with RUN/OFF/PULSE switch for control of motor.

† Solenoid valve. Pump is equipped with a remote control switch with 3,1 m cord.

‡ Some Power Team pumps are available in special configurations not listed in this catalog. Power Team can "Assemble to Order" pumps with special seals, voltages, valves, relief valve settings, etc. For your special requirements please consult your local distributor or the Power Team factory.



Electric Pump HYDRAULIC PQ120 SERIES

**Up to 400 Ton
1,6 l/min**

Low speed, high torque pump designed specifically for heavy duty, extended cycle operation. Ideal for press operation.

- Start and operate under full load, even with voltage reduced 10%.
- Electrical shut-down feature prevents unintentional restarting of motor following an electrical service interruption.
- Internal relief valve limits pressure to 700 bar. External relief valve is adjustable from 70 to 700 bar.
- Pump prewired at factory with a 2,24 KW, 380 volt, 50 Hz. 3 Phase motor. Other electrical configurations are available. See ordering information on the following page.
- 24 volt control circuits on units with remote controls for added user/operator safety.
- 2,24 KW(3 phase) motor with thermal overload protection. Motor starter and heater element supplied as standard equipment; no hidden charges!
- Metal shroud keeps dirt and moisture out of motor and electrical components.
- Pumps operate below maximum OSHA noise limitation.



PQ1203



PQ1204



PQ1204S-E380

700 bar

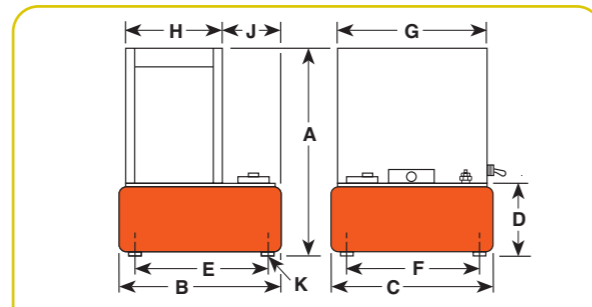
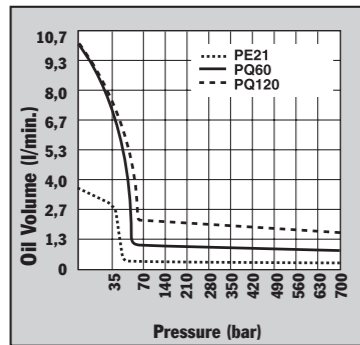

Pump No.	Max. Pressure Output bar	Oil Del. (l/min at...)	Noise level at Idle and 700 bar (dBA)	Amp Draw at 700 bar (A)	Oil Del. (l/min at...)				Dimensions (mm)							Prod. Wt. w/Oil (kg)			
					7 bar	70 bar	350 bar	700 bar	A	B	C	D	E	F	G		H	J	K***
PQ120-Series	700	1.437	73/78*	See Chart Above	9,7	2,1	1,7	1,6	638	362	394	184	308	338	373	237	122,2	1/2-20 UNF	74,3**

* Measured at a 0,9 m distance, all sides.
 ** Total weight with oil and 3-way solenoid valve. Subtract 4,5 kg to obtain weight of pump with manual valve.

*** For 50,8 mm dia. swivel casters, order (4) No. 10494.

For use with cyl.-type	Description	Order No.	Valve Type	Valve No.	Valve Function	Motor	Reservoir Usable (l)
Single-acting	2,24 KW pump with 21,6 l reservoir and manual valve.	PQ1203-E380	3-Way	9520*	Advance Hold Return	2,24 KW, 400 Volt 50 Hz, 3 Phase	20
Single-acting	PQ1203-50-380, except has solenoid operated remote valve.	PQ1203S-E380	3-Way	9599†	Advance Hold Return	2,24 KW, 400 Volt 50 Hz, 3 Phase	20
Double-acting	2,24 KW pump with 21,6 l reservoir and manual valve.	PQ1204-E380	4-Way	9506*	Advance Hold Return	2,24 KW, 400 Volt 50 Hz, 3 Phase	20
Double-acting	PQ1204-50-380, except has solenoid operated remote valve.	PQ1204S-E380	4-Way	9512†	Advance Hold Return	2,24 KW, 400 Volt 50 Hz, 3 Phase	20

* Manual valve. Pump is equipped with RUN/OFF/PULSE switch for control of motor. ‡ Some Power Team pumps are available in special configurations not listed in this catalog. Power Team can "Assemble to Order" pumps with special seals, voltages, valves, relief valve settings, etc. For your special requirements please consult your local distributor or the Power Team factory.
 † Solenoid valve. Pump is equipped with a remote control switch with 3,1 m cord.



Electric Pump HYDRAULIC PE400 SERIES

Up to 1,000 Ton 5,6 l/min

High tonnage double-acting cylinders, Single or multiple cylinder applications. Up to 1,000 Tons

- Two-speed high output pump delivers up to 16 l/min of oil.
- Low noise level of 73-80 dBA.
- Integral electrical shut-down feature prevents unintentional restarting of motor following an electrical service interruption. Over-current protection prevents damage to motor as a result of overheating.
- "Stop" and "Start" control buttons are 24 volt. PE4004 has a 4-way/3-position manual valve. The PE4004S has a 4-way/3-position solenoid valve with a 24 volt remote hand switch.
- External pressure relief valve is adjustable from 100 to 700 bar.
- Heavy duty 50,8 mm dia. casters assure easy maneuvering.
- 75,7 l (62,8 l usable) reservoir has a low oil level sight gauge.
- Powered by a dual voltage 7,46 KW, 3 phase, 1,437 rpm motor.
- 3 phase motor has all the electrical components necessary to operate the pump. The customer has no hidden charges when making purchase.
- Deliver 16 l/min. of oil at 15 bar, 5,6 l/min. of oil at 700 bar.

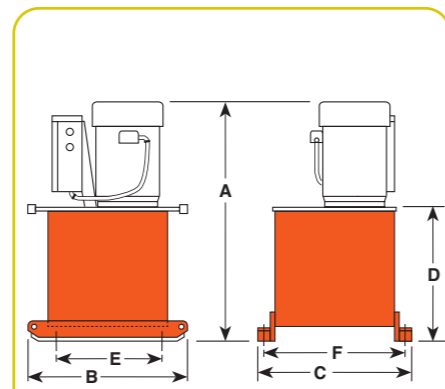
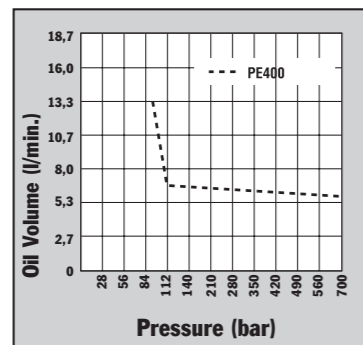

Pump No.	Max. Pressure Output bar	rpm	Noise level at Idle and 700 bar (dBA)	Amp Draw at 700 bar (A)	Oil Del. (l/min at..)				A* (mm)	B (mm)	C (mm)	D (mm)	E Caster Mfg. (mm)	F Caster Mfg. (mm)	Prod. Wt. w/Oil (kg)
					15 bar	90 bar	350 bar	700 bar							
PE4004-E380	700	1.437	73/80	6	16	14	6	5,6	924	635	610	540	394	546	223
PE4004S-E380	700	1.437	73/80	6	16	14	6	5,6	924	635	610	540	394	546	229

* Add 127 mm and 3,6 kg when casters are mounted. (Units are supplied with four 102 mm dia. swivel casters.)



PE4004S pump and RD3006 cylinder used in a special press which repairs damaged chain links for the shipping industry.



PE4004S

700 bar

For use with cyl.-type	Description	Order No.	Valve Type	Valve No.	Valve Function	Motor††	Reservoir Usable (l)
Double-acting	7,46 KW pump with 75,5 l reservoir and manual valve.	PE4004-E380	4-Way	9506	Advance Hold Return	7,46 KW, 400 volt 50 Hz, 3 Phase	62,8†
Double-acting	PE4004, except has solenoid operated remote valve.	PE4004S-E380	4-Way	9512**	Advance Hold Return	7,46 KW, 400 volt 50 Hz, 3 Phase	62,8†

** Solenoid valve with remote control.

† Usable oil is calculated with oil fill at recommended level at 57 mm below cover plate.

†† PE400 series available in 220/380V, 50Hz and 460V, 50Hz. Please specify when ordering. Example: PE4004-50-380 or for 460 V PE4004-460.

NOTE: Valves for spring return cylinders are available upon request. Consult the factory.



Crimping Pump

ELECTRIC HYDRAULIC PE-NUT

0,49 l/min
Two-Speed

Extremely durable yet lightweight and operate under low-line voltage conditions.

PE-NUT PUMP – 115V

- 0,46 KW universal electric motor (50 cycle)
- Two-stage pump for rapid ram advance
- Operational under low-line voltage conditions
- Optional operating pressures available; consult Power Team for details
- Designed for use with spring-returned remote tools
- High-pressure safety relief valve
- Remote hand control with 3,1 m cord
- Carrying handle
- Factory filled oil reservoir
- Pressure matched quick-coupler supplied
- Optional carrying case
- Two-stage pumping system
- Unique, intermittent duty pump
- Piston-type high-pressure pump supercharged by a low-pressure pump.



CAUTION: DESIGNED FOR CRIMPING APPLICATIONS ONLY! This system should not be used for lifting.

Order No.	Oil Delivery (l/min.)	Oil Reservoir qt. (l)	Usable Oil qt. (l)	Overall Width (mm)	Overall Length (mm)	Overall Depth (mm)	Pump Weight w/Oil (kg)
PE-NUT	2,62 at 7 bar	6	2,8	165	365	210	12,6
PE-NUTC*	0,49 at 700 bar						

*Includes Case

Electrical Data	
Electric Motor	Electrical Control
0,46 KW, 10,000 rpm 115V AC, 50 Hz 11 amp current draw (115V at 700 bar)	Remote control with 10-foot cord

Crimping Pump

GAS HYDRAULIC PG120

2,1 l/min
Two-Speed

Two-stage pump for rapid advance

GASOLINE POWER PUMPS

PG1203-CP

- 4,5 Kw Briggs & Stratton engine
- Manual control valve
- High-pressure safety relief valve
- Protective roll cage
- For use with single acting tools

PG1203/4S-CP

- 4,1 Kw Honda OHV-type engine
- Remote hand control with 3,1 m cord
- Two-stage pump for rapid advance
- High-pressure safety relief valve
- Protective roll cage
- For use with either single or double acting tools



CAUTION: DESIGNED FOR CRIMPING APPLICATIONS ONLY! This system should not be used for lifting.

Order No.	Oil Delivery (l/min.)	Oil Reservoir (l)	Usable Oil (l)	Overall Width (mm)	Overall Length (mm)	Overall Height (mm)	Pump Weight w/Oil (kg)
PG1203-CP	8 at 7 bar	11,3	7	502	552	622	80
PG1203/4S-CP	2,1 at 700 bar						



Gasoline Pump

HYDRAULIC PG30/55 SERIES

0,5 - 0,9 l/min
Gasoline driven

Gasoline power supply ideal for remote locations. PG30 series for to 75 ton cylinders. PG55 series for up to 150 ton cylinders.

PUMPS



PG303

- A logical choice at work sites where electricity or compressed air are unavailable. For single- or double-acting cylinders at operating pressures to 700 bar.
- All gasoline engine/hydraulic pumps feature "Posi-Check" valve to guard against pressure loss when valve is shifted from "advance" to "hold".

PG303 and PG304

- Powered by a 2-cycle, 1,5 kW Tecumseh engine giving it the lowest weight to horsepower ratio of all gasoline driven pumps. Has an aluminum reservoir with 6 l of usable oil.
- Has same basic pump as PE30 series electric operated pumps.
- PG30 series pumps are equipped with roll cages to protect pump from damage.
- PG30 series pumps weigh in at only 14,5 kg with oil.
- PG303 is for single-acting cylinders, has a 9520 valve with separate internal return line; allows oil from running pump to return to reservoir, independently of cylinder return oil, when valve is in "return" position.
- PG304 is for double-acting cylinders, has a 9506 4-way (tandem center) valve.



PG554

700 bar

PG553 and PG554

- 4,5 Kw Intek "Diamond Edge" 4-cycle, by Briggs & Stratton 19 l reservoir.
- Same basic pump as PE55 series electrical Vanguard® pumps.
- PG553 has a 9520 3-way valve for single-acting cylinders.
- PG554 has a 9506 4-way valve for double-acting cylinders.

PUMPS



Gasoline Powered Hydraulic Pumps like this PG303 help provide hydraulic force at remote locations.

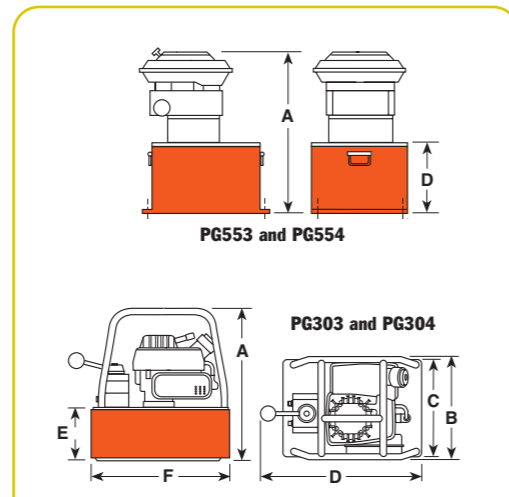
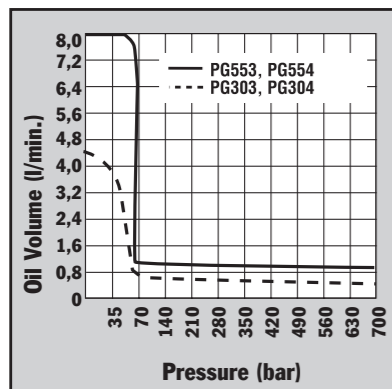

Pump No.	Max. Pressure Output bar	rpm	Oil Del. (l/min at...)				A (mm)	B (mm)	C (mm)	D (mm)	E (mm)	F (mm)	Prod. Wt. w/Oil (kg)
			7 bar	0 bar	350 bar	700 bar							
PG303, PG304	700	6.000	4,4*	0,6	0,6	0,5	378	264	241	406	130	343	14,5
PG553, PG554	700	3.600	7,7	1,2	1,1	0,9	559	457	318	219	422	229	54,4

* First stage oil delivery from 0-28 bar at 3,7 l/min minimum.

For use with cyl.-type	Description	Order No.	Valve Type	Valve No.	Valve Function	Reservoir Usable (l)	Kw	Cycle
Single-acting	1,5 Kw pump with 7,6 l reservoir and single-acting valve.	PG303	3-Way	9520	Advance Hold Return	6	1,5	2
Single-acting	4,5 Kw pump with 21,6 l Reservoir and single-acting valve.	PG553	3-Way	9520	Advance Hold Return	20,8**	4,5	4
Double-acting	PG303, except has double-acting valve.	PG304	4-Way	9506	Advance Hold Return	6	1,5	2
Double-acting	PG553, except has double-acting valve.	PG554	4-Way	9506	Advance Hold Return	20,8**	4,5	4

** Usable oil is calculated with oil fill at recommended level at 13 mm below cover plate.



Gasoline Pump PG120-PG400 SERIES

2,1 - 6,4 l/min
Max.output gasoline
powered pumps.

Large reservoir capacity roll
cage equipped. PG120 for up
to 300 ton cylinders. PG400 for
up to 1,000 ton cylinders.

PUMPS

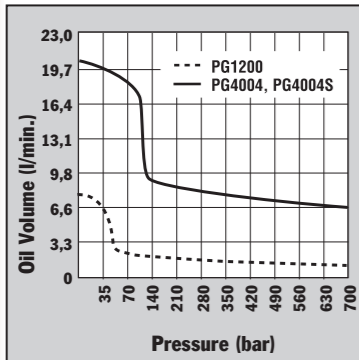

- Two-speed high performance pumps ideal for construction, structure moving and rigging applications.
- A logical choice at work sites where electricity or compressed air are unavailable. For single- or double-acting cylinders at operating pressures to 700 bar.
- All gasoline engine/hydraulic pumps feature "Posi-Check®" valve to guard against pressure loss when valve is shifted from "advance" to "hold".
- PG1200 Series pumps powered by a Honda 4-cycle, 5.5 hp engine with automatic decompression and electronic ignition. Deliver over 2,1 l/min at 700 bar.
- A 19 liter reservoir means adequate capacity for multi-cylinder applications. Dual element air cleaner protects engine from dusty environments.

700 bar



PG4004S

- Heavy duty "roll cage" provides pick-up points for lifting. Horizontal bars on PG1203, PG1204 and PG1204S protect unit, provide hand holds for carrying.
- Rubber anti-skid insulation on bottom of reservoir resists skidding and dampens vibration. PG1200M-4 and PG1200M-4D include a pump cart with 305 mm wheels.
- Adjustable external pressure regulator.

PG1204S



PG1200M-4

- For single-acting cylinders. Has 9520 3-way/3-position (tandem center) valve, 9596 load lowering valve and 9644 4-port manifold with individual needle valves at each port.
- Has a 9796 coupler and 9797 dust cap at each port. Valving permits precise individual control of up to four cylinders.
- A 9052 heavy duty, fluid filled pressure gauge (0-700 bar) is included.

PG1200M-4D

- For single- or double-acting cylinders with precise individual control of up to four cylinders possible.
- Equipped same as PG1200M-4, except has 9506 4-way/3-position (tandem center) valve, and second

4-port manifold without needle valves mounted beneath 9644 manifold for operating double-acting cylinders.

PG400 Series Maximum output Hydraulic Power Package

- Ideal for single or multiple cylinder applications. Has a 4-cycle, 15 kW Honda engine and 76 l reservoir (63 l usable) with low oil level sight gauge.
- Steel "roll cage" protects pump, has a lifting hook; 102 mm dia. swivel casters provide mobility.
- Delivers 6,4 l/min of oil at maximum

PG1200M-4D



- operating pressure.
- Has a 9506 4-way valve. On/off switch and speed control are protected by a panel. Sturdy molded case protects battery (not included).

PUMPS

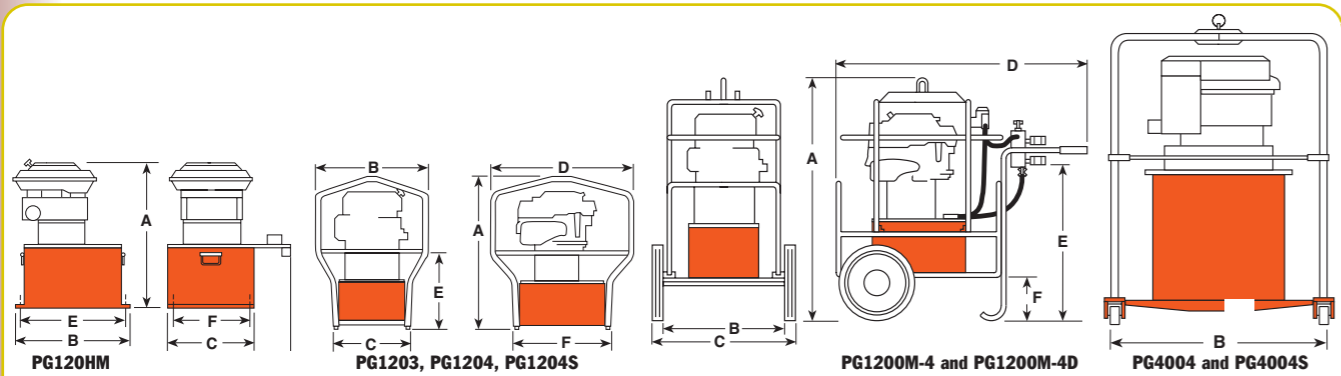

Pump No.	Max. Pressure Output bar	rpm	Oil Del. (l/min @)				Prod.						Wt. w/Oil (kg)
			7 bar	70 bar	350 bar	700 bar	A (mm)	B (mm)	C (mm)	D (mm)	E (mm)	F (mm)	
PG120HM	700	3,600	7,7	2,8	2,4	2,1	584	394	362	483	338	308	68
PG1203	700	3,600	7,7	2,8	2,4	2,1	708	514	362	667	343	464	70
PG1204	700	3,600	7,7	2,8	2,4	2,1	708	514	362	667	343	464	70
PG1204S	700	3,600	7,7	2,8	2,4	2,1	708	514	362	667	343	464	73
PG1200M-4	700	3,600	7,7	2,8	2,4	2,1	1070	457	635	1080	667	184	118
PG1200M-4D	700	3,600	7,7	2,8	2,4	2,1	1070	457	635	1080	667	184	127
PG4004	700	3,600	19,8	17,9	7,6	6,4	1276	1321	1321	-	-	-	197
PG4004S	700	3,600	19,8	17,9	7,6	6,4	1276	1321	1321	-	-	-	200

For use with cyl.-type	Description	Order No.	Valve Type	Valve No.	Valve Function	Reservoir		
						Usable (l)	Kw	Cycle
Single-acting	Base model 4,1 Kw gasoline pump with 22 l reservoir.	PG1203	3-Way	9520	Advance Hold Return	20,8	4,1	4
Single-acting	PG1203 with cart, rollcage, load lowering valve, 4 port manifold & gauge.	PG1200M-4	3-Way Manifold	9520 9644	Advance Hold Return**	20,8	4,1	4
Single-acting/ double-acting	PG1200M-4D, except without "Roll Cage" and cart. Ideal for house moving industry.	PG120HM	4-Way Manifold	9506 9642	Advance Hold Return**	20,8	4,1	4
Double-acting	Base model 4,1 Kw gasoline pump, with 22 l reservoir and double-acting valve.	PG1204	4-Way	9506	Advance Hold Return	20,8	4,1	4
Double-acting	PG1204, except has roll cage, cart, solenoid valve and 7,6 m cord.	PG1204S	4-Way Solenoid***	9516	Advance Hold Return	20,8	4,1	4
Double-acting	PG1200M-4, except for double-acting systems.	PG1200M-4D	4-Way Manifold	9506 9644	Advance Hold Return**	20,8	4,1	4
Double-acting	Base model 15 Kw pump with 76 l reservoir.	PG4004	4-Way	9506	Advance Hold Return	62,8*	15	4
Double-acting	PG4004, except has solenoid operated remote valve.	PG4004S	4-Way Solenoid***	9516	Advance Hold Return	62,8*	15	4

* Usable oil is calculated with oil fill at recommended level at 57 mm below cover plate.

** Control up to 4 cylinders independently.

*** Has 7,6 m remote control cord.



Intensifier HYDRAULIC

Pressure ratio 5:1

Converts low-pressure portable hydraulic pumps or on-board hydraulic systems, into high pressure power sources.

PUMPS

- Applications include utilities, railroads, construction, riggers and others.
- Operates single- or double-acting cylinders, jacks, and tools such as crimpers, spreaders, cable cutters, or tire tools.
- May be used to operate two separate, single-acting tools (with integral valves) independently, without need for additional manifold.
- Compact and rugged for use inside a utility vehicle aerial bucket or stowing in a vehicle.
- Control valve included. Other Power Team valves available as an option to suit your specific application, if needed; consult factory.
- No reservoir level to maintain; uses low pressure system as oil supply.
- Has 3/8" NPTF ports; compatible with standard fittings for low and high pressure systems.



HB443

700 bar

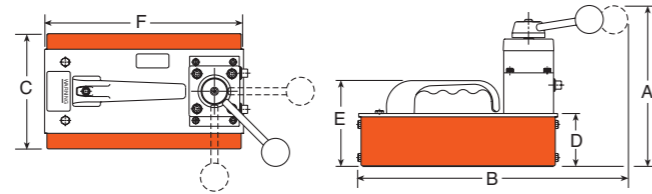

Pump No.	Output Flow at 700 bar	A (mm)	B (mm)	C (mm)	D (mm)	E (mm)	F (mm)	Prod. Wt. (kg)
HB44-Series	0,7 l/min.	210	368	156	70	114	267	7,2

For use with Cyl. Type	Description	Order No.	Valve Type	Valve No.	Output Flow Valve Function	Input Flow Range (l/min)	Input Flow Pressure (bar)	Output Flow Range (l/min)
Single-Acting	Hydraulic intensifier for single-acting systems	HB443	3-Way 3-Position	9520*	Advance Hold Return	0 - 38	20 - 138	0 - 9,5
Single-Acting/ Double-Acting	Hydraulic intensifier for double-acting systems	HB444	4-Way 3-Position	9506*	Advance Hold Return	0 - 38	20 - 138	0 - 9,5
Double-Acting	Hydraulic intensifier for double-acting torque wrench tools	HB445-RR	4-Way 3-Position	-	Advance Hold Return	0 - 38	20 - 138	0 - 9,5

† For maximum efficiency, recommended input flow is 19 l/min at a maximum pressure of 140 bar. Higher flows and/or pressures must be compensated for at the system pump (e.g., relief valve, variable flow devices, etc.).

* Posi-Check® valve design, "Posi-Check®" guards against pressure loss when valve is shifted from "advance" position to "hold" position.



Power Team pushes bridge construction

Assemble to Order Pumps

CUSTOM BUILT HYDRAULIC PUMP

Choose your basic pump, make your selections, and we will assemble, test and ship your pump.

PUMPS

700 bar



1
PE55A
PE55B
PE55F
PE90C
PE90A
PE90B



2
PE55C
PE55D
PE55F
PE90C
PE90D
PE90F



3
PE120M



4
PA55A
PA90A



5
PG55A

ORDER A "CUSTOM BUILT" HYDRAULIC PUMP

"Assemble to Order" means you can choose a basic pump with gas, air or electric motor. Then select the proper valve, gauge, pressure control, motor control and reservoir. You get a two-stage pump that gives high oil volume for fast cylinder approach (and return with double-acting cylinders) in the first stage and high pressure in the second stage.

1 0,83 KW UNIVERSAL MOTOR

These motors start under full load and are suitable for operation up to 350 or 700 bar. The motor is 0,83 KW, 12,000 rpm, 115 or 230 volt, 50 cycle A.C. single phase (25 amp draw at 115V.). With proper valve they can be used with single- or double-acting cylinders. Remote control available.

2 1,1 KW JET MOTOR, SINGLE & THREE-PHASE

Feature low noise level, moderate speed for long service and are ideal for fixed applications. Motor is 1,1 KW, 3.450 rpm, 115 or 230 volt, 50 cycle, A.C. single phase with thermal overload switch. Can be used with single- or double-acting cylinders and equipped with remote control. Also available in 230/460 volt, three-phase (specify).

NOTE: These do not start under full load unless valve is in "neutral" (requires open or tandem center valve) and are not recommended for frequent starting and stopping.

3 2,2 KW JET MOTOR, THREE-PHASE

Gives low noise level and long life due to its moderate operating speed. Ideal for fixed installations. Consists of basic 700 bar pump, jet pump motor: 2,2 KW, 3.450 rpm, 230/460 volt, 50 cycle, A.C. three-phase, with thermal overload switch. Equipped with internal and external relief valve. Will start under load.

4 2,3 KW AIR MOTOR

This pump is ideal for use where electricity is unavailable or cannot be used. The 350 or 700 bar pump has a 2,3 KW air driven motor at 3.000 rpm (optimum performance based on 6 bar air pressure and 1165 l/min 1419 l/min at the pump). You can drive single- or double-acting cylinders with the correct valve.

NOTE: 6 bar air supply required to start under full load.

5 GASOLINE ENGINE

This version is perfect when electricity and air are unavailable. It is capable of continuous operation at full pressure. Consists of basic 700 bar pump, 4-cycle Briggs & Stratton "Diamond Edge" gasoline engine, developing 4,5 KW. As with all these pumps, this unit can be valved for use with either single- or double-acting cylinders.

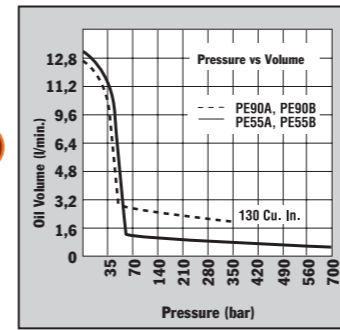

dBA @ idle and 700 bar - 90/95
dBA @ idle and 350 bar - 90/95

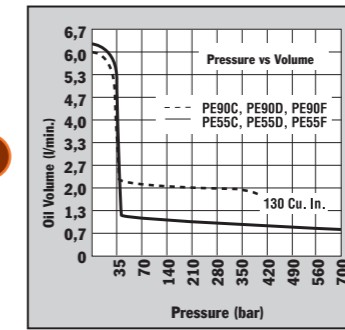

dBA @ idle and 700 bar - 80/85

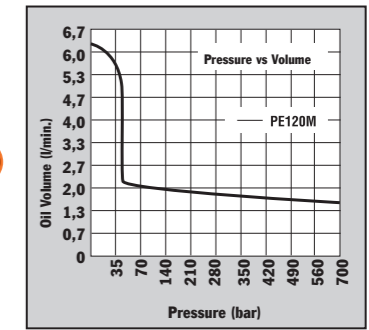

dBA @ idle and 700 bar - 80/85

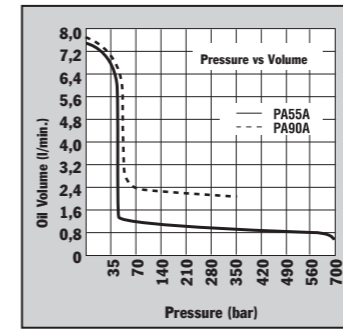

dBA @ idle and 700 bar - 83/88
dBA @ idle and 350 bar - 83/88

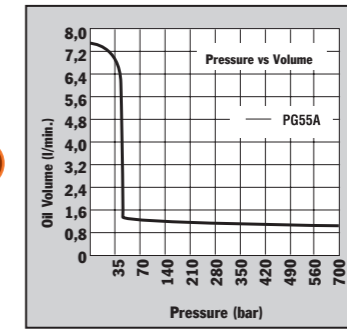

"ASSEMBLE TO ORDER" SYSTEM HOW TO ORDER YOUR "CUSTOM" HYDRAULIC PUMP . . .

You can choose from pre-engineered, off-the-shelf components to customize your pump. All the components are listed in table form, with key letters or numbers on pages 114-115. Complete instructions guide you through

so you can determine what is needed to complete a pump assembly. Shown below is an example of a custom-built pump.

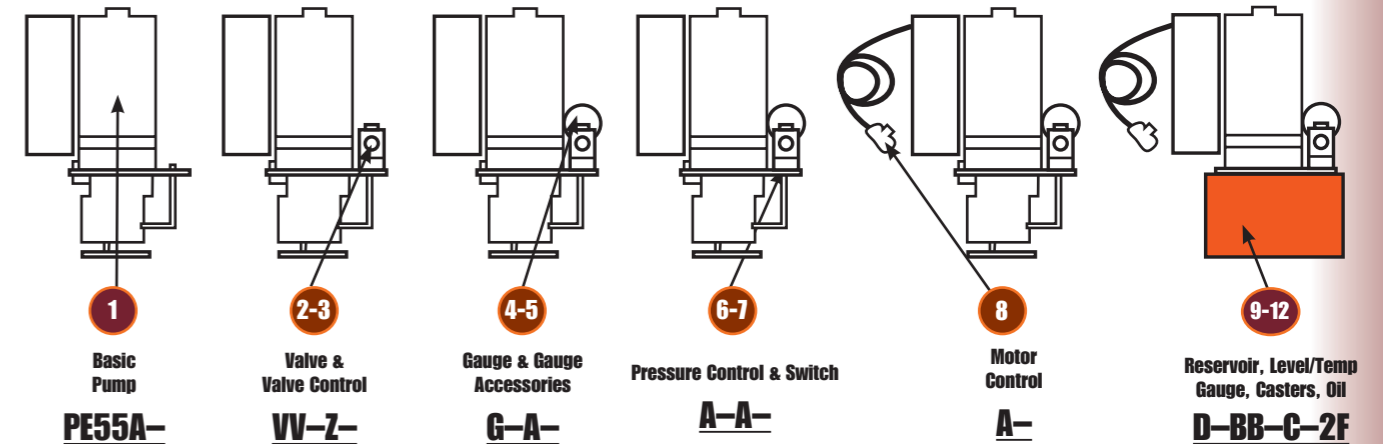

Pump No. PE55A-VV-Z-G-A-A-A-A-D-BB-C-2F is a 700 bar two-speed pump with a 115 volt, 50Hz, single phase, 1,12 KW, 12,000 rpm motor;

a 9512 4-way solenoid valve with a 202778 remote hand control, a 9041 pressure gauge, no gauge accessories,

standard pressure control, standard On-Off-Pulse motor control, 400630R9 7,6 liter reservoir, a 350431 oil level/temperature gauge, 10494 casters, and 7,6 liter of standard hydraulic oil.

See next two pages for pump components



PUMPS

Assemble to Order System

PUMP COMPONENT SPECIFICATION CHART

TO BUILD YOUR PUMP, FILL IN KEY LETTERS FROM CHARTS

1 Basic Pump	2 Select Valve	3 Select Valve Control	4 Select Gauge	5 Select Gauge Accessories	6 Pressure Control
7 Pressure Switch	8 Motor Control	9 Reservoir	10 Level/Temp Gauge	11 Choose Casters	12 Select Oil

Use the charts numbered from 1-12 below to select the pump, valve, gauge and other miscellaneous accessories to suit your needs. For the pump, fill in the basic number plus key letter in block 1 above and the key letter only in the blocks 2-12 above for any of the other items. Refer to the appropriate pages in this catalog for more specific information on the products you need.

1 BASIC PUMP (See pages 94-106)

BASIC PUMP NUMBERS						SPECIFICATIONS		
PE55 (700 bar)	PE90 (350 bar)	PE120 (700 bar)	PA55 (700 bar)	PA90 (350 bar)	PG55 (700 bar)	NOTE: Customer must specify voltage required.		
						Power Source	rpm	KW
A or AC*	A or AC*					115V-60 Hz, 1Ø	12,000	0,84
						110V-50 Hz, 1Ø	12,000	0,84
B or BC*	B or BC*					230V-60 Hz, 1Ø	12,000	0,84
						220V-50 Hz, 1Ø	12,000	0,84
† C or CC*	† C or CC*					115V-60 Hz, 1Ø	3,450	1,12
† C50	† C50					110V-50 Hz, 1Ø	2,850	1,12
† D or DC*	† D or DC*					230V-60 Hz, 1Ø	3,450	1,12
† D50	† D50					220V-50 Hz, 1Ø	2,850	1,12
† F60 **	† F60**					208, 230/460V-60 Hz, 3Ø	3,450	1,12
† F50 **	† F50**					220/380V-50 Hz, 3Ø	2,850	1,12
		M60 **				208, 230/460V-60 Hz, 3Ø	3,450	2,24
		M50 **				220/380V-50 Hz, 3Ø	2,850	2,24
			A	A		Air Motor	3,000	2,24
					A	Gas Engine	3,600	4,47

*Suffixes AC, BC, CC & DC indicate pumps for Canadian orders only.

NOTE: All electric units have 24 volt secondary circuit.

**Specify voltage required.

† These pumps do not start under full load unless valve is in "neutral"

position (requires open or tandem center valve) and are not recommended for frequent starting and stopping.

2 VALVE (See pages 50-60)

Manifold/Manual/Air Operated Directional Valves	Function	Manifold/Manual/Air Operated Directional Valves	Function
AB 9628 manual, tandem center	4-way, 3 pos. valves	O 9609 manual, pressure compensated flow control	3-way, 4 pos.
AC 9632 manual "twin" tandem and open center		R 9506 manual, tandem center "Posi-Check®"	
A None	—	RR 9511 manual, open center	4-way,
B 9626 manifold	Manifold	S 9500 manual, tandem center	3 pos.
C 9584 manual	3-way,	T 9507 manual, closed center "Posi-Check®"	valves
D 9582 manual	2 pos.	U 9501 manual, closed center	
E 9610 automatic, pilot operated	valves	Solenoid Operated Directional Valves	
G 9504 manual	3/4-way,	FF 9569 solenoid operated - 24 volt	3-way, 2 pos.
JJ 9594 air operated	2 pos. valves	HH 9572 solenoid operated - 24 volt	3/4-way, 2 pos.
L 9502 manual, closed center "non-interflow"	3-way,	PP 9599 solenoid operated - 24 volt	3-way, 3 pos.
M 9520 manual, tandem center "Posi-Check®"	3 pos.	VV 9512 solenoid operated - 24 volt	4-way,
N 9576 manual, metering tandem center	valves	WW 9615 solenoid operated - 24 volt	3 pos. valves

3 VALVE CONTROL (See page 116)

Valve Remote Control	Use with Valve	Valve Remote Control	Use with Valve
A None	—	Z 202778 remote hand control, 3,1 m	9512 or 9615
X 304718 remote hand control, 3,1 m	9572	ZF 309653 remote foot control, 3,1 m	9512, 9615,
XF 309652 remote foot control, 3,1 m	9572		9569 or 9599
Y 202777 remote hand control, 3,1 m	9569 or 9599	ZZ 209593 remote hand control, 3,7 m	9594

4 GAUGE (See page 124-125)

Pressure Gauges	
A	None
B	Other - Specify
G	9041 0-10.000 psi - 0-700 Bar (63 mm dia.)
H	9040 0-10.000 psi - 0-700 Bar (Liquid) (63 mm dia.)
J	9051 0-10.000 psi - 0-700 Bar (100 mm dia.)
M	9052 0-10.000 psi - 0-700 Bar (Liquid) (100 mm dia.)

6 PRESSURE CONTROL (See page 133)

Pressure Controls	
A	With standard external pressure regulator
C	Other - specify
D	350199 premium external pressure regulator. See Power Team Catalog product No. 9633 for details.

NOTE: Pressure controls are factory pre-set at 700 bar unless otherwise specified.

8 MOTOR CONTROL (See page 116)

Electric Motor Controls	
A	Standard On/Off/Pulse control (does not include remote switch) for A, B, C, D, F and M electric pumps. Also used for remote controlled solenoid valves.
B	None
C	25017 remote motor hand switch, 3,1 m.
D	203225 remote motor hand switch, 3,1 m. (heavy duty)
E	10461 remote motor foot switch, 3,1 m.
Air Motor Controls	
AA	Other
B	None
P	27876 hand motor control (for PA55 & PA90 series)
Q	27877 foot motor control (for PA55 & PA90 series)

10 OIL LEVEL/TEMP. GAUGE (SEE PAGE 118)

Oil Level/Temperature Gauge	
A	None
BB	350431 oil level/temperature gauge

11 CASTERS (See page 124)

Casters	
A	None
C	10494 caster for use with 400630R9 reservoir (Specify quantity of four)

5 GAUGE ACCESSORY (See page 125)

Gauge Accessories	
A	None
N	9049 pulsation dampener - All dry gauges

7 PRESSURE SWITCH (See page 117)

Pressure Switch	
A	None
B	9625 electric pressure switch (35-700 bar)
NOTE: Pressure switch is factory pre-set at 700 bar unless otherwise specified.	
C	9641 pilot operated air control valve - N.C.
D	9643 pilot operated air control valve - N.O.

9 RESERVOIR (See page 119)

Reservoirs	Capacity
A	None
B	Other - Specify
D	400630R9 - PE55, PE90, PE120, PA55 and PA90 series
E	61165† - PE55, PE90, PE120, PA55 and PA90 series (Oil temperatures in excess of 65.5° C. may cause permanent failure of the thermoplastic reservoir)
F	RP22‡ - PE55, PE90, PE120, PA55 and PA90 series
H	617990R9 Same as D except with drain port
J	RP50 - PE55, PE90, PE120, PA55 and PA90 series
K	401370R9 - PG55 series
P	209124 - PE55, PE90, PE120, PA55 and PA90 series
V	RP100 - PE55, PE90, PE120, PA55 and PA90 series
W	RP101 - PG55 series

NOTE: Includes cover adapter and misc. accessories when applicable.

†High density polyethylene.

‡Aluminum.

12 OIL (See page 126)

Oil	
E	Ship pump without oil
F	9637 3,8l. standard hydraulic oil
G	9638 9,5l. standard hydraulic oil
Q	9639 3,8l. Flame-Out hydraulic oil
R	9640 9,5l. Flame-Out hydraulic oil
U	9645 3,8l. biodegradable hydraulic oil
V	9646 9,5l. biodegradable hydraulic oil

NOTE: Select type of hydraulic oil and specify quantity.

25017
202777
202778
304718



203225



10461



251660



309652
309653



209593



17627
216209



ON/OFF MOTOR CONTROL

The following remote control switches will give you momentary "ON" control of your hydraulic pump. These switches are deadman type, spring loaded to the "OFF" position. They can be used with any Power Team electric hydraulic pumps.

No. 25017 - Remote hand control. Has a push button switch, with a 3,1 m cord. Wt., 0,4 kg.

No. 203225 - Remote hand control. Heavy-duty with single push button switch in a neoprene housing with 3,1 m cord. Housing seals out dust, lint and liquids (unit is not submersible). Wt., 0,4 kg.

No. 10461 - Remote foot control, with 3,1 m cord. Wt., 1,4 kg.

No. 251660 - Remote foot control, with 3,1 m cord.

For use with the PE10 style pumps. Wt., 0,4 kg.

SOLENOID & MOTOR CONTROL

For use on solenoid valves that are used on single-acting cylinders:

No. 202777 - Remote hand control. Has rocker style switch that is momentary advance, spring center hold and detented retract. It comes with a 3,1 m cord, for use with 3-way/2 or 3-position valves. Wt., 0,4 kg. For use on solenoid valves that are used on double-acting cylinders:

No. 202778 - Remote hand control. Has rocker style switch that is momentary advance, spring center hold and momentary retract. It comes with a 3,1 m cord, for use with 4-way/3-position valves. Wt., 0,4 kg.

No. 309653 - Remote foot control. Can be used in place of either of the above hand controls to control the same type of valves. The switch is momentary on both the advance and retract position and is spring centered to the hold position. This foot switch comes with 3,1 m cord. Wt., 1,8 kg.

No. 17627 - Remote foot control. Same as the No. 309653 but without a cord. Wt., 0,9 kg.

No. 304718 - Remote hand control. Has a rocker style switch that is momentary advance, spring center hold and momentary retract. The switch is wired to start and stop the motor when the valve is energized. It comes with a 3,1 m cord. To be used with 4-way/2-position valves. Wt., 0,4 kg.

No. 309652 - Remote foot control. Has same functions as No. 304718. Supplied with a 3,1 m cord. To be used with 4-way/2-position valves. Wt., 1,8 kg.

No. 216209 - Remote foot control. Same as the No. 309652, but without a cord. Wt., 0,9 kg.

NOTE: See valves listing to determine which remote to use. Page 44-51.

REMOTE AIR MOTOR CONTROLS

This remote hand control has two momentary push buttons, one for advance and one for retract with spring offset to hold. To be used with 4-way/2-position air pilot valves.

No. 209593 - Remote hand control with 3,7 m cord. Wt., 0,9 kg.

SUBPLATES

For remote mounting of control valves. They convert pump mounted valves to remote mounted valves quickly and easily.

No. 9510 - Subplate for remote mounting the following valves; 9500, 9501, 9502, 9504, 9506, 9507, 9511, 9552, 9572, 9575, 9576, 9592, 9594 and 9609. Wt., 1 kg.

No. 9620 - For use with 9500, 9501, 9502, 9552, 9572, 9592 and 9594. Same as No. 9510 but has integral pressure regulating valve. Wt., 1,7 kg.

PUMP-MOUNTED SUBPLATES

When fitted between pump cover plate valve mounting flange and control valve, provides a separate 3/8" NPTF female port, open to "return" regardless of position of valve. Also provides a separate 3/8" NPTF female pressure port. This subplate can be useful when you desire to use one pump with a deck-mounted control valve, plus a separate remote-mounted valve to control another function. For use with the following valves: 9500, 9501, 9502, 9504, 9506, 9507, 9511, 9552, 9572, 9575, 9576, 9592, 9594 and 9609.

No. 9515 - Subplate, Wt., 0,6 kg.

No. 9521 - Subplate for use under most pump mounted valves to provide adjustable pressure control on units not equipped with an external pressure regulator. Wt., 1,7 kg.

AIR FILTER/REGULATOR/LUBRICATOR

Recommended for use with single-speed air/hydraulic pumps found on pages 55-69.

No. 9531 - Filter/regulator. 1/4" NPTF inlet and outlet. Wt., 0,4kg.

PRESSURE SWITCH

Application: Used in a hydraulic circuit where system pressure must be "held". Automatically (electrically) turns off pump motor when predetermined system pressure is reached. Attaches directly to control valve manifold or can be mounted "in-line" to read system pressure. Has a 1/4" NPTF male thread, and a 1/4" NPTF fitting for gauge mounting if required. Adjustable from 70 to 700 bar. Can also be used to actuate other electrical devices in the system. Wired "normally open" and held closed by spring pressure.

IMPORTANT: Electrical rating of switch is 5 amps at 250 volts max. To prevent permanent damage to switch, a control relay must be installed to handle currents or voltage exceeding these limits. Pressure switch should never be used to directly actuate the electrical motor.

No. 9625 - In-line pressure switch with 1/4" NPTF gauge port. Wt., 0,5 kg.

PILOT OPERATED AIR CONTROL VALVES

Application: For use when an air pilot signal is required at a set hydraulic pressure.

Can be used to shift valves, and start or stop pneumatic pumps.

Attaches directly to control manifold or can be mounted "in-line" to read system hydraulic pressure. Automatically turns on an air pilot signal when a predetermined system pressure is reached. Has 1/4" NPTF male thread and 1/4" NPTF fitting for gauge mounting if required. Adjustable from 35-700 bar. Maximum rating of 700 l at 7 bar.

No. 9641 - Pilot operated control valve, normally closed, with 1/4" NPTF male thread. Wt., 0,4 kg.

No. 9643 - Same as 9641 except normally open. Wt., 0,4 kg.

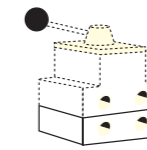

9510 and 9620 attach to the bottom of valve for remote mounting. The 9515 and 9521 mount between the pump cover plate and valve.

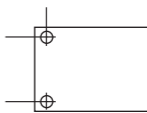

9510
9515



9620

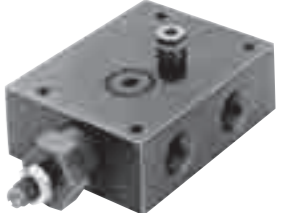

9521

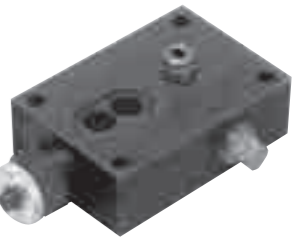

9531



9625

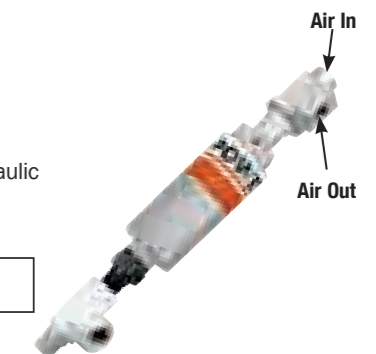
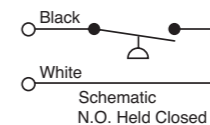

9641
9643

Hydraulic Pump ACCESSORIES

PUMPS

252511
252512



206767
250175



350431

10494

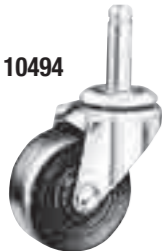

207762



16339

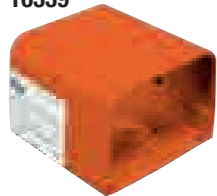

Viton* seal kits

OIL COOLER KITS

No. 252511 - Oil cooler kit designed for use with PE604T or PE604PT pumps with 115 VAC. Wt., 2,2Kg.

No. 252512 - Oil cooler kit designed for use with PE604T or PE604PT pumps with 220 VAC. Wt., 2,2 kg.

RESERVOIR BREATHER KITS

No. 206767 - Reservoir breather kit designed for use on PA17, PA55, PE17, PE55, PE84, PE90, PE120, PG55, PG120, PQ60 and PQ120 series pumps. Wt., 0,6 kg.

No. 250175 - Reservoir breather kit designed for use on PE21 and PE46 series pumps. These kits replace the reservoir filler cap when the pump is used in dusty and dirty environments. Wt., 0,6 kg.

CASTERS

50,8 mm diameter casters attach to the bottom of large reservoir for portability. Sold individually; order the amount you need.

No. 10494 - Single caster wheel. Wt., 0,1kg.

FLUID LEVEL/TEMPERATURE GAUGE

Displays fluid level and temperature of hydraulic oil in reservoir. 32°-212°F, 0°-100°C. 32 mm wide and 162 mm high.

No. 350431 - Fluid level/temperature gauge.

FOOT CONTROL GUARD

Guard for use with 10461 and 251660 foot controls.

No. 16339 - Wt., 2 kg.

MAGNETIC STRIP

Magnetic strip with adhesive back can be added to No. 25017, 202777, 202778 and 304718 hand controls. Provides 2,7 kg. of holding force.

No. 207762 - Wt., 0,1 kg.

VITON* SEAL KITS

(SEE PAGE 33)

Order Number	Use With	Model
300507	P12	All
300472	P23, P55	All
300510	P59	All
300508	P157, P159, P300	A
300690	P157, P159	B
300696	P300	B
300508	P157D, P159D, P300D	A
300693	P157D, P159D	B
300699	P300D	B

VITON* SEAL KITS Can be used in all "C" and "RH" series cylinders (see pages 14-15 and 22-23), as well as the P12, P55, P59, P157/P159, P157D/P159D and P300/P300D series of hand pumps. These seals are required when fire resistant hydraulic fluids are used. For use with phosphate ester fluids. Not required with Flame-Out fluid.

* Viton is the E.I. duPont De Nemours & Co., Inc, trade name for fluoroelastomers.

UNIVERSAL PUMP CART

Mobilize your hydraulic pumps with the PC200. The rugged tubular frame can easily handle pumps weighing up to 90 kg. With 305 mm wheels, the cart rolls easily. Just load the pump onto the cart and wheel it right to the job. The universal mounting hole pattern lets you handle a wide variety of Power Team pumps.

No. PC200 - Universal pump cart with 305 mm wheels. Cart can be used with the following pumps: PA60, PA64 and PA554 air/hydraulic pumps; PE55 series, PE183-2 and PE184-2 electric/hydraulic pumps; PE21, PQ60 and PQ120 series "Quiet" pumps; PG55 series gas engine/hydraulic pumps; and pumps with optional 19- and 38 l - reservoirs; Nos. RP50, RP51, RP101 and RP103. Wt., 12,3 kg (Shown with pump, pump not included)



PROTECTIVE PUMP ROLL CAGE

Safeguards pump, gas engine and valves on the job site. Horizontal bars provide convenient hand holds for carrying pump, a pick-up point permits lifting unit with an overhead crane or other device. Standard equipment on PG1203 and PG1204. Can be ordered as an option with any other gas, air, or electrically driven hydraulic pump equipped with a 38 l reservoir.

Note: Refer to PG1203/PG1204 specification chart (pages 108-109) for dimensions of roll cage.

No. PC200RC - Roll cage for use with PC200. (Cannot be used on pumps with 38 liter reservoirs.) Wt., 16 kg.

No. RC5 - Roll cage. Wt., 9 kg.

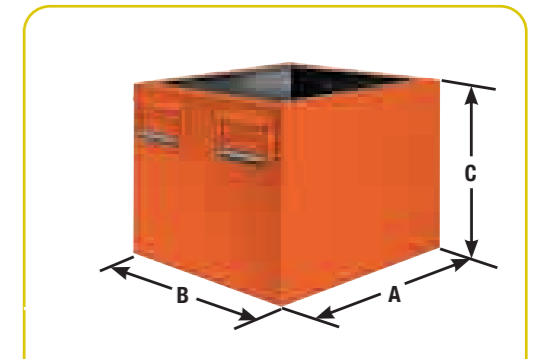

LARGE CAPACITY RESERVOIRS

Capacity (liter)	Order Number	Usable Oil (l/min)	Use With	Size (mm)		
				A	B	C
7,6	RP20**	7,1	PA6, PA50 series (models A-E)	292	241	165
7,6	RP20-F**	7,1	PA6 series (model F), PA 50 series (model F & G)	292	241	165
9,5	RP20M*	7,2	PA6, PA50 series (models A-E)	292	241	165
9,5	RP20M-F*	7,2	PA6 series (model F), PA50 series (model F & G)	292	241	165
9,5	RP21*	7,2	PE18 series	292	241	165
9,5	RP22†	7,1	PE55, PE90, PE120, PA55	292	241	165
19	RP50	18,4	PE55, PE90, PE120, PA55	381	318	203
19	RP51	18,4	PA46, PE46, PE21	381	318	203
37,9	RP100	35,1	PE55, PE90, PE120, PA55	381	318	356
37,9	RP101	35,1	PG55, PG120	381	318	356
37,9	RP103*	37,0	PQ60, PQ120	392	362	313
37,9	RP104	35,1	PA46, PE46, PE21	381	318	356

* Four mounting holes: 1/2"-20, for 50.8 mm diameter swivel casters (No. 10494)

** High density polyethylene reservoir. † Aluminum reservoir.

NOTE: All metal reservoirs are equipped with drain plugs and all necessary conversion items.

Hydraulic oil is not included with reservoir kits. Please order separately. See page 126.

METAL RESERVOIR CONVERSION KITS FOR PUMPS *INCLUDES GASKETS AND FASTENERS.

Metal Pump Number	Res. Order Number	Metal Reservoir Capacity (l)	Reservoir Weight (kg)	Metal Pump Number	Res. Order Number	Metal Reservoir Capacity (l)	Reservoir Weight (kg)	Metal Pump Number	Res. Order Number	Metal Reservoir Capacity (l)	Reservoir Weight (kg)
PA6	213896	1,7	1,4	PA50	213896	1,7	1,4	PA174	213895	9,5	4,1
PAGA	213896	1,7	1,4	PA50R	213896	1,7	1,4	PE172	213895	9,5	4,1
PAGD	213896	1,7	1,4	PA6R	213896	1,7	1,4	PE172A	213895	9,5	4,1
PAG-2	213895	9,5	4,1	PA50R2	213895	9,5	4,1	PE172S	213895	9,5	4,1
PAGD2	213895	9,5	4,1	PA172	213895	9,5	4,1	PE174	213895	9,5	4,1

PUMPS

HYDRAULIC ACCESSORIES



HOSES Page 122
 Rubber
 Polyurethane
 Non-Conducting



COUPLERS Page 123
 Quick Connect
 Flush Face



GAUGES Page 124-125
 Heavy Duty Hydraulic Pressure Gauges
 Digital and Analog



FLUIDS Page 126
 Standard Oil 0,9 l, 3,8 l, 9,5 l, 208 l
 Flame Out 3,8 l, 9,5 l
 Bio Degradable 3,8 l, 9,5 l
 Low Temperature 3,8 l



MANIFOLDS Page 127
 Standard Blocks
 Blocks with Valves



700 BAR FITTINGS Page 128
 Connectors
 Couplings
 Crosses
 Elbows
 Tees
 Swivels
 Special Adapters



VALVES Page 129-133
 In-Line
 Remote
 See Also Pump Mounted...pages 45-51



Hoses

Polyurethane Rubber Non-Conductive

- 3/8" NPTF fittings on both ends.
- Operating pressure is 700 bar.
- All comply with SAE 100R10 standard.

A Non-conductive hose

For applications requiring electrical isolation by the hose, non-conductive hose has a leakage factor of less than 50 microamperes, considered a safe level of conductivity by SAE standards. The covering is polyurethane and colored orange for easy identification as non-conductive hose. The covering is not perforated, preventing moisture from entering the hose and affecting its overall conductivity. All non-conductive hoses have a minimum burst pressure of 2.800 bar.

B Rubber hose

6 spiral (R13 specification) rated hose reinforced with two braids of high tensile steel wire and have a tool 4:1 safety factor. The rubber covering is oil and weather resistant.

C Polyurethane hose

Made with Nylon core and then one braid of Aramid and one braid of wire reinforcement with a orange polyurethane cover (Conductive). 4:1 safety factor standard 700 bar WP / 2800 bar BP.

D Hydraulic hose assembly

No. 9764E - Hose assembly consisting of 9767E (1,8 m hose), 6,4mm I.D. polyurethane with 9798 hose half coupler and 9800 dust cap.

No. 9754 - Hose assembly consisting of 9756 (1,8 m hose), 6,4 mm I.D. rubber with 9798 hose half coupler and 9800 dust cap.

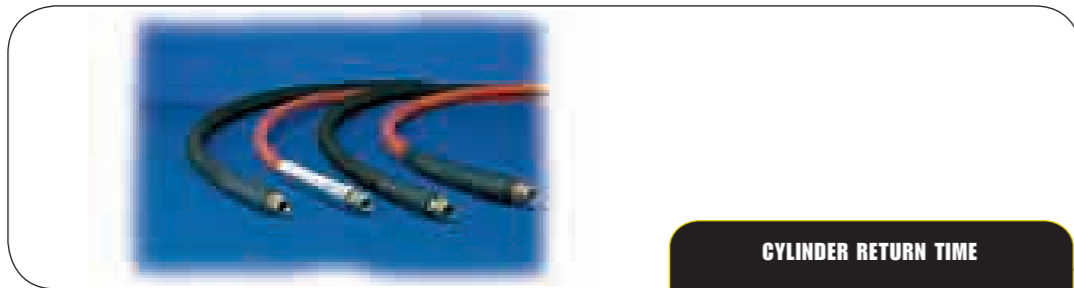

The figures show the relative effect two styles of hose can have on return time. Actual times may vary.

CYLINDER RETURN TIME		
Cylinder	No. 9769E 3,1 m Hose 6,4 mm I.D.	No. 9781E 3,1 m Hose 9,5 mm I.D.
C2514C	51 sec.	14 sec.
C556C	1 min., 30 sec.	24 sec.
C5513C	4 min., 12 sec.	59 sec.
C10010C	6 min., 56 sec.	1 min., 3 sec.

ORDERING INFORMATION

Hose Type	Hose I.D.	Hose Length	Burst Rating	Order No.	Hose Type	Hose I.D.	Hose Length	Burst Rating	Order No.
Polyurethane	6,4 mm	0,6 m	2 800 bar	9765E	Rubber, Wire-braid	6,4 mm	2,4 m	2 800 bar	9757E
Polyurethane	6,4 mm	0,9 m	2 800 bar	9766E	Rubber, Wire-braid	6,4 mm	3,1 m	2 800 bar	9758E
Polyurethane	6,4 mm	1,8 m	2 800 bar	9767E	Rubber, Wire-braid	6,4 mm	3,7 m	2 800 bar	9759E
Polyurethane	6,4 mm	1,8 m	2 800 bar	9764E*	Rubber, Wire-braid	6,4 mm	6,1 m	2 800 bar	9760E
Polyurethane	6,4 mm	2,4 m	2 800 bar	9768E	Rubber, Wire-braid	6,4 mm	9,1 m	2 800 bar	9761E
Polyurethane	6,4 mm	3,1 m	2 800 bar	9769E	Rubber, Wire-braid	6,4 mm	15,3 m	2 800 bar	9762E
Polyurethane	6,4 mm	3,7 m	2 800 bar	9770E	Rubber, Wire-braid	9,5 mm High Flow	0,9 m	2 800 bar	9733E
Polyurethane	6,4 mm	6,1 m	2 800 bar	9771E	Rubber, Wire-braid	9,5 mm High Flow	1,8 m	2 800 bar	9776E
Polyurethane	6,4 mm	15,3 m	2 800 bar	9772E	Rubber, Wire-braid	9,5 mm High Flow	3,1 m	2 800 bar	9777E
Polyurethane	6,4 mm	22,9 m	2 800 bar	9750E	Rubber, Wire-braid	9,5 mm High Flow	4,6 m	2 800 bar	9734E
Polyurethane	6,4 mm	30,5	2 800 bar	9751E	Rubber, Wire-braid	9,5 mm High Flow	6,1 m	2 800 bar	9778E
Polyurethane	9,5 mm High Flow	1,8 m	2 800 bar	9780E	Rubber, Wire-braid	9,5 mm High Flow	9,1 m	2 800 bar	9735E
Polyurethane	9,5 mm High Flow	3,1 m	2 800 bar	9781E	Rubber, Wire-braid	9,5 mm High Flow	12,2 m	2 800 bar	9736E
Polyurethane	9,5 mm High Flow	6,1 m	2 800 bar	9782E	Rubber, Wire-braid	9,5 mm High Flow	15,3 m	2 800 bar	9779E
Polyurethane	9,5 mm High Flow	15,3 m	2 800 bar	9783E	Non-Conductive	6,4 mm	1,8 m	2 800 bar	9773
Rubber, Wire-braid	6,5 mm	0,9 m	2 800 bar	9755E	Non-Conductive	6,4 mm	3,1 m	2 800 bar	9774
Rubber, Wire-braid	6,5 mm	1,8 m	2 800 bar	9756E	Non-Conductive	6,4 mm	6,1 m	2 800 bar	9775
Rubber, Wire-braid	6,5 mm	1,8 m	2 800 bar	9754E*					



NOTE: Polyurethane hoses not recommended for use where heat or weld splatter conditions exist. Other lengths available on request

*Furnished with 9798 hose half coupler and 9800 dust cap.

Couplers

Standard & Flush-Face

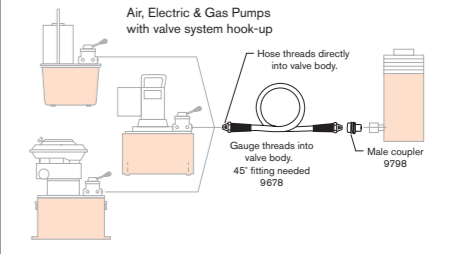
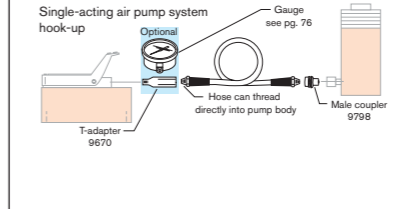
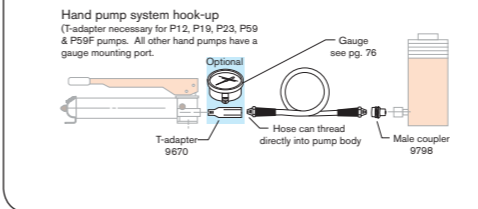
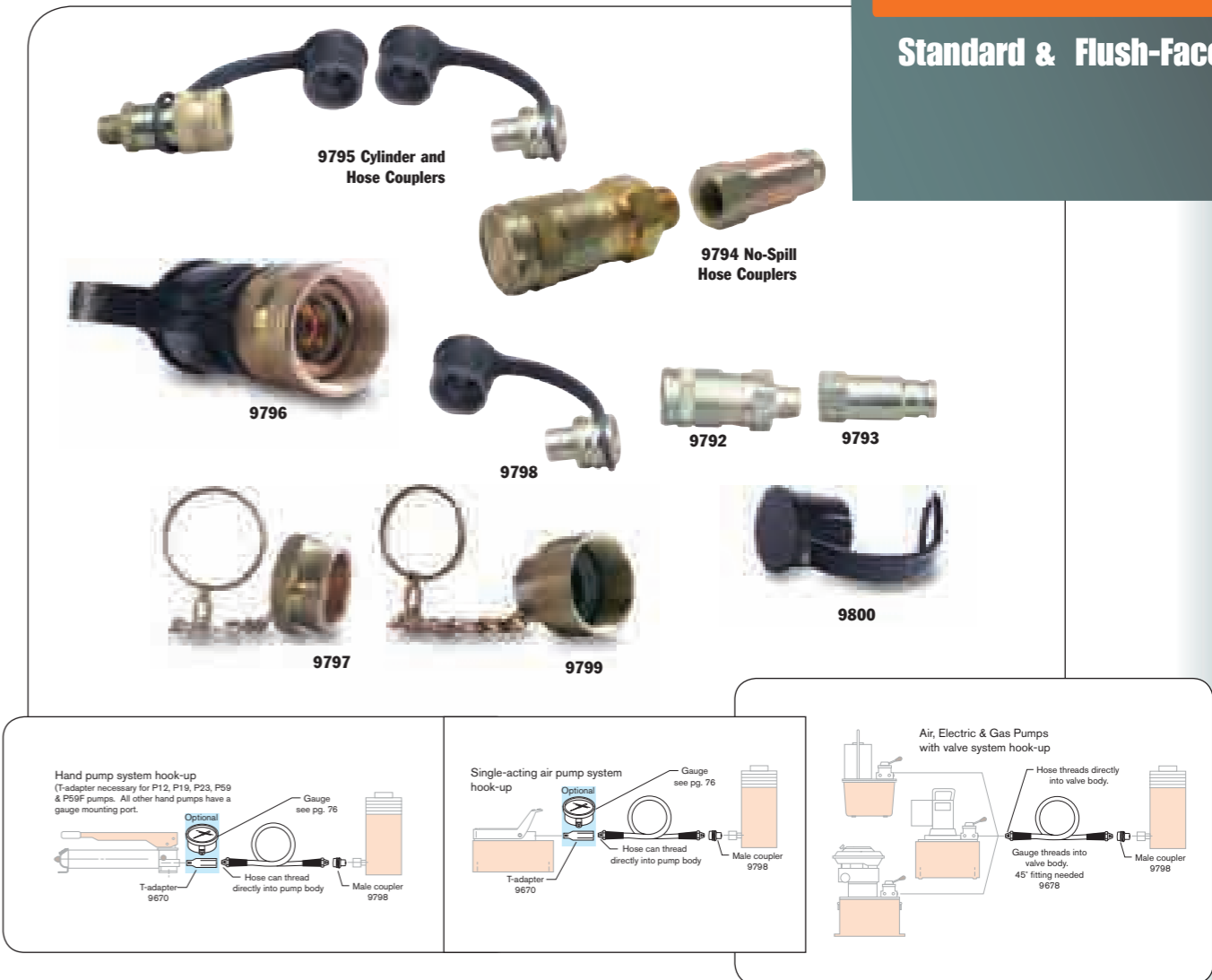

CYLINDER AND HOSE COUPLERS

Designed for use up to 700 bar with hydraulic jacks, cylinders, etc. They are the threaded union type for interchanging cylinders in seconds. Each half is valved with a precision ball for a tight shutoff when disconnected. These couplers also permit the separation of cylinders or hose from pump when at 0 psi with minimal oil loss.

No. 9795 - Complete quick coupler, 3/8" NPTF. (Includes two 9800 dust caps.)

No. 9798 - Male (hose) half coupler (includes hose half dust cap), 3/8" NPTF.

No. 9796 - Female (cylinder) half coupler with No. 9800 dust cap, 3/8" NPTF.

No. 9796-V - Same as 9796, but with Viton seals.

No. 9796-E - Same as 9796, but with EPR seals.

No. 9799 - Optional metal dust cap (hose half).

No. 9797 - Optional metal dust cap (cylinder half).

NO-SPILL, PUSH-TO-CONNECT HYDRAULIC HOSE COUPLERS

High flow, no-spill, push-to-connect couplers with locking collar and flush face designed for high pressure applications. The flush-face concept makes it easy to clean both coupler ends before connecting. Our unique push-to-connect, "dry-break" design eliminates oil spillage. The locking collar makes accidental disconnects a thing of the past. For 700 bar operation. Designed to permit high oil flow.

No. 9792 - Female (cylinder) half quick coupler only. Wt., 0,1 kg.

No. 9793 - Male (hose) half quick coupler only. Wt., 0,1 kg.

No. 9794 - Complete quick coupler (male and female). Dust caps not included. Wt., 0,2 kg.

HYDRAULIC COUPLER DUST CAP

Dust cap fits either male or female half couplers.

No. 9800 - Dust cap. For male or female 3/8" NPTF half couplers. Wt., 0,1 kg.

Gauges

Analog & Digital



9042DG

Technical Attributes

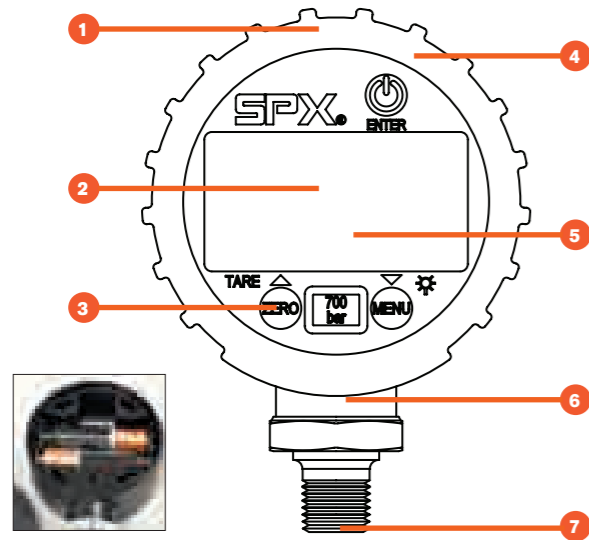

- 1 Protective rubber boot
- 2 Back-light and large 0.48 in (12.2 mm) display easy reading
- 3 Displays in multiple engineering units: psi, bar, mPa, inHg, kg/cm²
- 4 Weatherproof IP67 enclosure.
- 5 2,000 hr. life, (2) AA (LR6) batteries.
- 6 Typical Cycle Life: 10,000,000.
- 7 1/4" NPTF Male Threads.

Digital hydraulic pressure gauge

- Digital gauge is easier to read and offers better accuracy¹ than a conventional analog gauge.
- The laser welded stainless steel sensor & socket and the IP67 weatherproof rating make this product suitable for use in even the most demanding of applications. Five pre-programmed engineering units allow technicians to read pressure in the unit of measure most applicable to the process.
- The gauge also features a bar graph display for enhance visibility.
- Includes: automatic off (battery conservation), pressure tare, minimum pressure memory and maximum pressure.
- Vibration & Shock tested to MIL-STD-202G.
- Agency Compliance/Approval: RoHS, CE, ASME B40.7, UL, cUL 61010-1 memory.
- The gauges are calibrated for life at the factory. (They can be certified in the field if required).

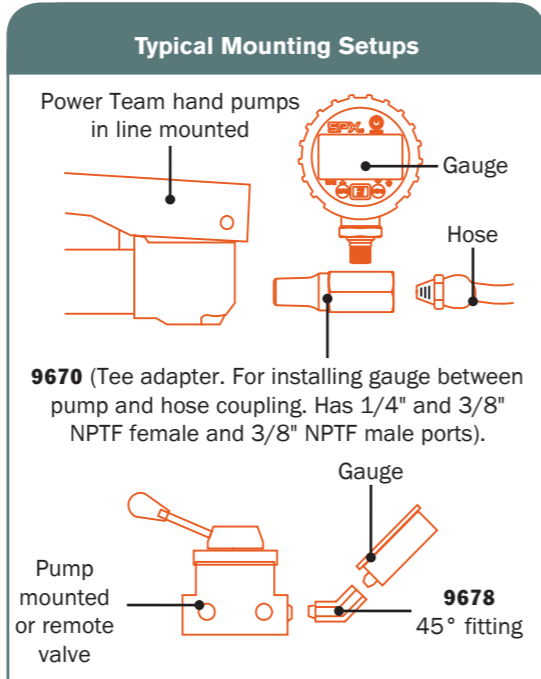

9670 (Tee adapter. For installing gauge between pump and hose coupling. Has 1/4" and 3/8" NPTF female and 3/8" NPTF male ports).

9678 Pump mounted or remote valve 45° fitting

Gauges

Analog & Digital

Heavy-duty Hydraulic Pressure Gauges

- Gauges feature an easily readable and highly visible, red day-glo needle.
- High strength steel bourdon tube ensures high cycle life.
- Have 1/4" NPT connections.



9049

9040E

STANDARD PRESSURE GAUGE ORDERING INFORMATION

Face Dia.	psi/Bar	Tons	Major Graduations	Minor Graduations	Silicone Filled	Use With Cylinder Series	Gauge No.
63,5 mm	0-10,000 /0-690	-	2000 psi, 100 Bar	200 psi, 20 Bar	Yes	All	9040E
100 mm	0-10,000 /0-690	-	1000 psi, 100 Bar	100 psi, 10 Bar	Yes	All	9052E
100 mm	0-10,000 /0-690	0-5	2000 psi, 1 Ton	200 psi, .1 Ton	Yes	C & RLS	9053E
100 mm	0-10,000 /0-690	0-10	2000 psi, 1 Ton	200 psi, .1 Ton	Yes	C, RD, RH, RLS & RSS	9055E
100 mm	0-10,000 /0-690	0-15	2000 PSI, 1 Ton	200 PSI, 0,2 Ton	Yes	C	9057E
100 mm	0-10,000 /0-690	0-17,5, 0-30 and 0-50	2000 psi, 5 Ton	200 psi, .5 Ton on 30, 50 Ton Scales; .2 Ton on 17.5 Ton Scale	Yes	RT172, RT302, RT503	9059E
100 mm	0-10,000 /0-690	0-20	2000 PSI, 5 Ton	200 PSI, 0,5 Ton	Yes	RH, RLS, RSS	9061E
100 mm	0-10,000 /0-690	0-25	2000 psi, 5 Ton	200 psi, .5 Ton	Yes	C & RD	9063E
100 mm	0-10,000 /0-690	0-30	2000 psi, 5 Ton	200 psi, .5 Ton	Yes	RH†, RLS & RSS	9065E
100 mm	0-10,000 /0-690	0-50	2000 psi, 5 Ton	200 psi, .5 Ton	Yes	RH†, RLS & RSS	9067E
100 mm	0-10,000 /0-690	0-55	2000 psi, 5 Ton	200 psi, .5 Ton	Yes	C, R, RA & RD	9069E
100 mm	0-10,000 /0-690	0-60	2000 psi, 5 Ton	200 psi, 1 Ton	Yes	RH	9071E
100 mm	0-10,000 /0-690	0-75	2000 psi, 5 Ton	200 psi, 1 Ton	Yes	C, RLS & RD8013	9073E
100 mm	0-10,000 /0-690	0-100	2000 psi, 10 Ton	200 psi, 1 Ton	Yes	C, R, RA, RD, RH, RLS†, RSS† & RT1004†	9075E
100 mm	0-10,000 /0-690	0-150	2000 psi, Initial 10 Then 20 Ton	200 psi, 2 Ton	Yes	C, R, RD & RLS	9077E
100 mm	0-10,000 /0-690	0-200	2000 psi, 20 Ton 10 Then 20 Ton	200 psi, 2 Ton	Yes	R, RD & RH†	9079E
150 mm	0-10,000 /0-690	0-690	1000 psi, 100 Bar	100 psi, 10 Bar	No	All	9089

† The tonnage scale on the gauge is based on a different effective area. A slight error in tonnage reading will occur relative to the different effective area.

HYDRAULIC ACCESSORIES

HYDRAULIC ACCESSORIES

Fluids HYDRAULIC

Standard, Flame Out®, Biodegradable and Low Temp.



Oil Description	Qty.	Order No.
Standard Oil	0,9 l	9636
Standard Oil	3,8 l	9637
Standard Oil	9,5 l	9638
Standard Oil	208 l	9616
Flame-Out®	3,8 l	9639
Flame-Out®	9,5 l	9640
Biodegradable	3,8 l	9645
Biodegradable	9,5 l	9646
Low Temp.	3,8 l	9647

SPECIFICATIONS

Description	Grade (ASTM)	Spec. Gravity		Color (ASTM)	Flash Point	Fire Point	Pour Point	Viscosity			Foam Test (ASTM)
		at 16°C (kg / l)						SUS @ (38°C)	SUS @ (99°C)	Viscosity Index	
Standard Oil	215	0.88		2.0	204°C	221°C	-34°C	215	48	100	Pass
Flame-Out®	220	0.91		Light Amber	260°C	288°C	-26°C	220	55	140	Pass
Biodegradable	—	0.92		2.0	224°C	NA*	-30°C	183	53	213	Pass
Low Temp.	—	0.87		6.5 (Red)	180°C	204°C	-45°C	183	52	190	Pass

*Not available.

Standard Hydraulic Oil

- For dependable performance of all your hydraulic pumps and cylinders.
- Contains foam suppressant additives and has a high viscosity index.

Flame-Out® 220 fire resistant hydraulic fluid

- Contains anti-rust, anti-foam and anti-sludge additives.
- Provides fire resistant protection.
- Provides maximum lubrication and heat transfer.
- Offers a wider operating temperature range.
- No need to change seals in your Power Team equipment. Just drain the standard oil and replace it with Flame-Out 220.

Biodegradable Hydraulic Fluid

- Biodegradable, non-toxic fluid withstands moderate to severe operating conditions; provides excellent protection against rust.
 - Offers superior anti-wear properties, has excellent multi-metal compatibility.
- Developed to meet stringent performance requirements and satisfy growing environmental needs for hydraulic fluids which are readily biodegradable and non-toxic. Can be used with all Power Team pumps, cylinders, valves and other accessories using standard seals. Depending on the contamination or degradation levels which might be present in used fluid, small amounts of this substance, if spilled, will not affect ground water or the environment. Acceptable methods of disposal include use as a fuel supplement. Since this fluid will not typically be hazardous waste, additional disposal options may be available,

including land farming or processing through sewage treatment facilities, if necessary approvals are obtained from appropriate regulatory authorities. This fluid has been tested against EPA 560/6-82-003 and OECD 301 for biodegradability, and toxicity has been tested against EPA 560/6-82-002 and OECD 203: 1-12. Not recommended for operation in temperatures below -7°C or above 71°C. Recommended storage temperatures not below -23°C or above 77°C.

For additional technical information or to order a **MATERIAL SAFETY DATA SHEET** call **1-800-477-8326**

Low-Temperature Oil

Provides smooth, reliable operation in the coldest climate conditions.

(Note: Will burn if heat source is extreme enough. Will not, however, propagate the flame and is self-extinguishing when there is no ignition source.)

Manifolds

Remote and Pump Mounted

Manifold No.	A (mm)	B (mm)	C (mm)
9627	406,4	114,3	38,1
9648	177,8	38,1	38,1

9,5 mm Ø THRU (MOUNTING HOLES) (4 PLACES) (REF.)

9,1 mm (REF.)

25,4 mm (REF.)

152,4 mm (REF.)

57,2 mm (REF.)

3/8" NPTF FEMALE (6 PLACES)

19 mm (REF.)

24,5 mm (REF.)

229 mm (REF.)

152,4 mm (REF.)

76,2 mm (REF.)

19 mm (REF.)

9644

(MOUNTING HOLES)

9,1 mm (REF.)

9,5 mm Ø THRU (3 PLACES) (REF.)

14,3 mm (REF.)

19 mm (REF.)

24,5 mm (REF.)

25,4 mm (REF.)

82,5 mm (REF.)

87,6 mm (REF.)

19 mm (REF.)

3/8" NPTF FEMALE (4 PLACES)

9642

No. 9691 – “Y” Manifold

Extremely useful when connecting two hydraulic cylinders to a single line. Has three 3/8" NPTF ports. Wt. 0,45 kg.

No. 9634 – Manifold block

This manifold is for multiple-cylinder installations, has four 3/8" NPTF ports and two 1/4" mounting holes. Wt. 0,7 kg.

No. 9635 – Manifold block

This hex-shaped manifold offers extra versatility with six 3/8" NPTF ports and two 1/4" mounting holes. Wt. 0,9 kg.

No. 9617 – Manifold block

When a multiple-cylinder installation is required, this manifold is invaluable. Has six 3/8" NPTF ports to handle larger multiple-cylinder systems. Wt. 1,4 kg.

No. 9648 – Manifold block

This 178 mm long manifold block has

seven 3/8" NPTF ports and two 6,4 mm mounting holes. Wt. 1,2 kg.

No. 9627 – Manifold block

This 406,4 mm long manifold block allows you to mount the 9575 or 9596 valves without interference. Has seven 3/8" NPTF ports and two 6,4 mm mounting holes. Wt. 2,7 kg.

No. 9626 – Pump mounted manifold block

Converts pumps with pump mounted valves for use with remote mounted valves. This manifold block is subplate mounted on the pump cover plate and provides 3/8" NPTF pressure and return ports. Maximum recommended flow rate is 19 l/min. Note: If used on PE30 or PG30 series pump, 12,7mm longer mounting screws are required. Order four (4) No. 11956 screws separately.

9642 AND 9644 MANIFOLD BLOCKS WITH NEEDLE VALVES

For independent multiple-cylinder operation, feature needle valves for precise manual control. Designed for remote-mounted applications. Can be used with all Power Team pumps.

No. 9642 – Manifold with two needle valves for control of two cylinders. Has four 3/8" NPTF ports. Wt. 3,7 kg

No. 9644 – Manifold with four needle valves for control of four cylinders. Has six 3/8" NPTF ports. Wt. 7,4 kg

Fittings

700 bar
Power Team fittings:
All applications.



	9190	Hyd. tubing. 3/8" O.D. x .065" wall, 15,3 m. (10 pieces 1,53 m long.) Wt. 5,5 kg.
	9670	Tee adapter. For installing gauge between pump and hose coupling. Has 1/4" and 3/8" NPTF female and 3/8" NPTF male ports. Wt. 0,2 kg.
	9671	Double tee adapter. Permits use of more than one cylinder in series with one pump. Three 3/8" NPTF female ports. Wt. 0,5 kg.
	9672	Service tee. Two 3/8" NPTF female internal, one 3/8" NPTF male external. Wt. 0,3 kg.
	9673*	Swivel connector. 3/8" NPSM male, 1/4" NPSM female. Wt. 0,1 kg.
	9674	Male connector. 43 mm long, 1/4" x 3/8" NPTF. Wt. 0,1 kg.
	9675*	Swivel connector. 3/8" NPTF male, 3/8" NPSM female. Wt. 0,1 kg.
	9676*	Swivel connector. 1/4" NPTF male, 3/8" NPSM female. Wt. 0,1 kg.
	9677*	45° swivel connector. 3/8" NPTF male, 3/8" NPSM female. Wt. 0,1 kg.
	9678	45° fitting. Used when mounting gauge at an angle on connection such as 9670. Male and female 1/4" NPTF ends. Wt. 0,1 kg.
	9679	Connector. 1/4" NPTF female and 3/8" NPTF male. Wt. 0,1 kg.
	9680	Coupling. Both ends 3/8" NPTF female. Wt. 0,1 kg.
	9681	Street elbow. Male and female 3/8" NPTF ends. Wt. 0,1 kg.
	9682	Male connector. 43 mm long, 3/8" NPTF male ends. Wt. 0,1 kg.

	9683	Male connector. 57 mm long, 3/8" NPTF male ends. Wt. 0,1 kg.
	9684	Male connector. 57 mm long, 1/4" NPTF male ends. Wt. 0,1 kg.
	9685	Coupling. 1/4" NPTF female and 3/8" NPTF female. Wt. 0,1 kg.
	9686	90° elbow. 3/8" NPTF female ends. Wt. 0,2 kg.
	9687	Pipe plug. Heat-treated, 3/8" NPTF. Wt. 0,1 kg.
	9688	Pipe plug. Heat-treated, 1/4" NPTF. Wt. 0,1 kg.
	9689	Connector. 1/4" NPTF male and 3/8" NPTF female. Wt. 0,1 kg.
	9690	Male connector. 43 mm long, 1/4" NPTF male ends. Wt. 0,1 kg.
	9692	Straight connector. 3/8" tube x 3/8" male NPTF. Wt. 0,1 kg.
	9693	90° elbow. 3/8" tube x 3/8" male NPTF. Wt. 0,1 kg.
	9694	45° elbow. 3/8" tube x 1/4" male NPTF. Wt. 0,1kg.
	9695	Tee. 3/8" tube. Wt. 0,1 kg.
	9696	Male run tee. 3/8" tube x 1/4" male NPTF. Wt. 0,1 kg.
	9697	Male branch tee. 3/8" tube x 1/4" male NPTF. Wt. 0,1 kg.
	9698	Cross. 3/8" tube. Wt. 0,2 kg.
	9699	45° gauge fitting. 3/8" NPTF male and female, and 1/4" NPTF female at 45°. Wt. 0,3 kg.
	9705	Fitting, swivel. 3/8" NPTF male to 3/8" NPTF female. 90° fitting with internal 370 micron screen. May be rotated 360° about male thread axis.

NOTE: Power Team hydraulic fittings are intended for use with our high pressure hydraulic products and are suitable for use at max. working pressures of 700 bar unless otherwise noted.

* **CAUTION:** On part numbers 9673, 9675, 9676 and 9677 the female swivel end of these adapters is a straight pipe thread (NPSM) with a 30° seat. All male pipe fittings that are used with these female swivel adapters must have an internal 30° seat in order to effect a proper seal. All Power Team male fittings are manufactured with a 30° seat except 9687 and 9688.

Valves

HYDRAULIC REMOTE/IN-LINE

Valve selection chart

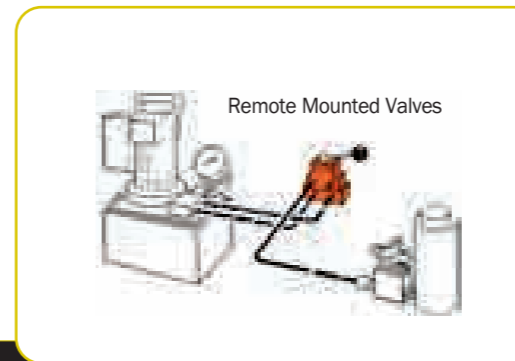

Order No.	Page No.	*Cylinder Application	Operation	Valve Type	Volt	Advance/Return	Advance/ Hold Return	Posi-Check Feature
9508	131	S.A. & D.A.	Manual	4-way, 3 Pos. Closed Center	—	no	yes	yes
9509	131	S.A. & D.A.	Manual	4-way, 3 Pos. Tandem Center	—	no	yes	yes
9514	131	D.A.	Solenoid	4-way, 3 Pos. Tandem Center	115	no	yes	yes
9524	130	S.A. & D.A.	Solenoid	3/4-way, 2 Pos.	230	no	yes	no
9525	131	D.A.	Solenoid	4-way, 3 Pos. Tandem Center	230	no	yes	yes
9526	131	S.A.	Solenoid	3-way, 2 Pos.	230	no	yes	no
9554	130	S.A. & D.A.	Solenoid	3/4-way, 2 Pos.	24	no	yes	no
9555	131	D.A.	Solenoid	4-way, 3 Pos. Tandem Center	24	no	yes	yes
9556	131	S.A.	Solenoid	3-way, 2 Pos.	24	no	yes	no
9559	131	S.A.	Solenoid	3-way, 2 Pos.	115	no	yes	no
9593	130	S.A. & D.A.	Solenoid	3/4-way, 2 Pos.	115	no	yes	no
9595	130	S.A. & D.A.	Air	3/4-way, 2 Pos.	—	no	yes	no

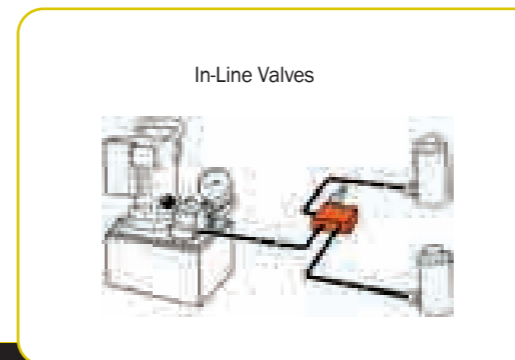

Order No.	Page No.	*Cylinder Application	Operation	Valve Type	Volt	Advance/Return	Advance/ Hold Return	Posi-Check Feature
9575	132	S.A.	Manual	Shut-Off Valve	—	—	—	—
9580	133	S.A.	Automatic	One-way Check Valve	—	—	—	—
9581	133	S.A. & D.A.	Automatic	Pilot Op. Check Valve	—	—	—	—
9596	132	S.A.	Manual	Load Lowering Valve	—	—	—	—
9597	132	S.A. & D.A.	Automatic	Sequence Valve	—	—	—	—
9608	132	S.A. & D.A.	Automatic	Pressure Reducing Valve	—	—	—	—
9623	133	S.A. & D.A.	Automatic	Pressure Relief Valve	—	—	—	—
9631	133	S.A. & D.A.	Automatic	Metering Valve	—	—	—	—
9633	133	S.A. & D.A.	Automatic	Pressure Regulator Valve	—	—	—	—
9720	132	S.A. & D.A.	Automatic	Counter Balance Valve	—	special	—	—
9721	132	S.A. & D.A.	Automatic	Counter Balance Valve	—	special	—	—
RV21278	133	—	Automatic	Relief Valve	—	—	—	—

"S.A." represents single-acting cylinders, "D.A." represents double-acting cylinders. For pump-mounted valves, see pages 51-57.

Valves

HYDRAULIC REMOTE MOUNTED

700 bar,
1/4" ports
19 l / min max flow

3/4-way/2-position solenoid
and air actuated valves

HYDRAULIC ACCESSORIES

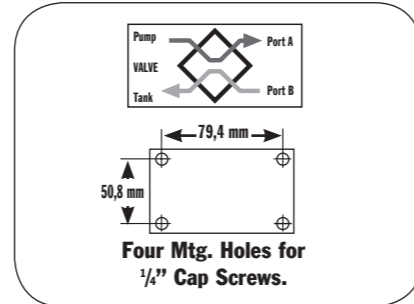
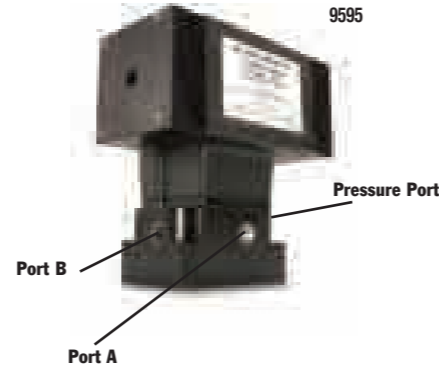
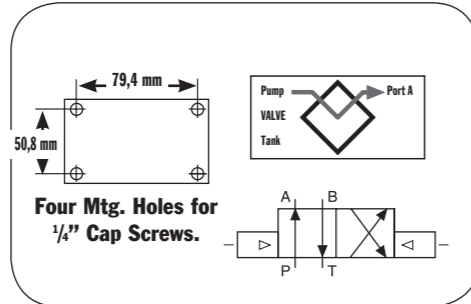
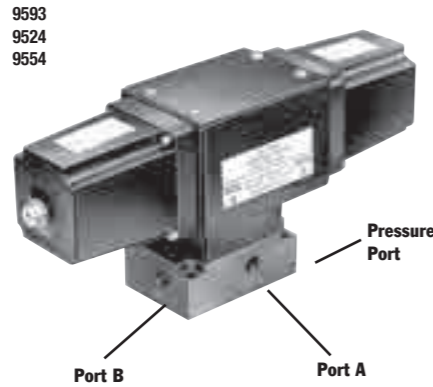

Application: Single- or double-acting cylinders.

Actuation: 9593, 9524 and 9554 are solenoid operated, 9595 is air operated.

Operation with single-acting cylinder: Either oil port "A" or "B" must be plugged on valve. With port "B" plugged, solenoid is energized to position "A," oil port "A" becomes pressurized. When solenoid is energized to position "B," oil port "A" becomes the return port.

Operation with multiple single-acting cylinders: A pressure line from one bank can be connected to oil port "A" and the other to oil port "B" on the valve. Sequence: When energized to position "A," oil port "A" becomes pressurized and clamps the fixture connected to oil port "A"; oil port "B" becomes a "return" port for cylinder connected to oil port "B," and retracts it. The opposite happens when solenoid "B" is energized.

Operation with double-acting cylinder: Port "A" is connected to "advance" port of cylinder, oil port "B" connects to cylinder "return" port. Solenoid is energized to position "A," oil port "A" becomes pressurized to extend cylinder piston. The opposite happens when solenoid "B" is energized. Valve does not hold in "retract" position.

NOTE: When using more than one valve on a pump, the tank port may require a check valve to permit inadvertent, momentary extension of a retracted cylinder.

NOTE: If pump is equipped with an internal outlet check, a "hold" position can be maintained with the pump shut off.

No. 9593 – 3/4-way/2-position, remote mounted solenoid valve, 115 volt, 50/60 Hz. Wt., 7 kg.

No. 9524 – Same as 9593 except with 230 volt, 50/60 Hz.

No. 9554 – Same as 9593 except with 24 volt, 50/60 Hz.

No. 9595 – Same as 9593 except is air operated (minimum of 3,5 bar air pressure required). Wt., 5,2 kg.

NOTE: Valves above are shipped without controls. The 9524, 9554 and 9593 can be used with the 304718 remote hand control (see page 106). The 9595 can be used with the 209593 remote hand control (see page 106).

NOTE: Valves have 1/4" NPTF ports. 3/8" to 1/4" adapters are included.

NOTE: Maximum tank line pressure for remote mounted valves is 35 bar.

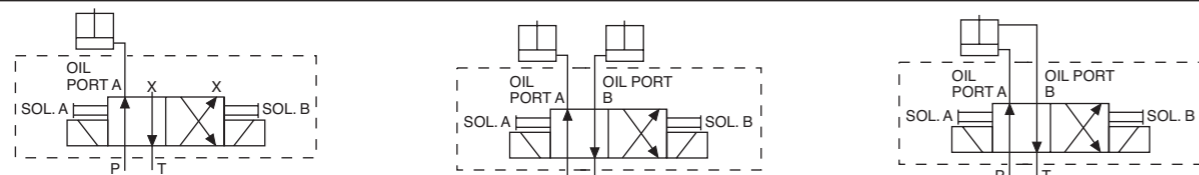

1. To actuate one single-acting cylinder.
2. To actuate two single-acting cylinders.
3. To actuate one double-acting cylinder.

NOTE: Valves above are shipped without control switch. Use 202777 remote hand switch (see page 116).

CAUTION: To prevent sudden, uncontrolled descent of a load as it is being lowered, use a No. 9596 Load Lowering Valve or No. 9720 Counter Balance Valve (see page 132) in conjunction with the directional valve used in your application.

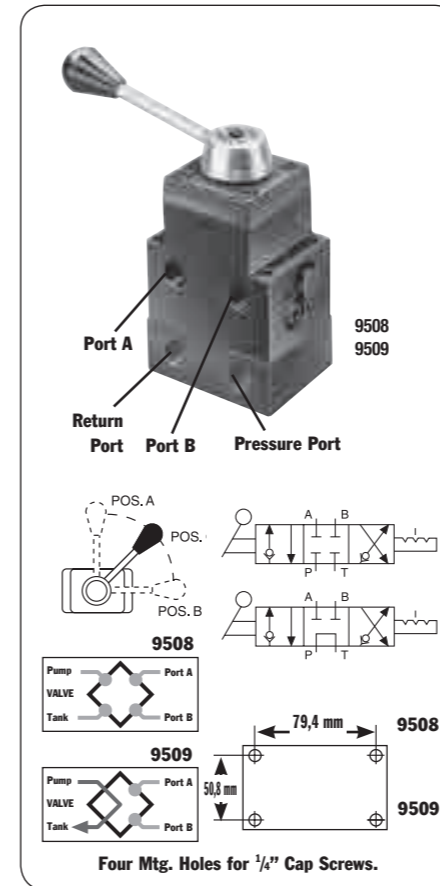

4-way/3-position (closed center) and (tandem center) manual valves with Posi-Check®

Application: Single- or double-acting cylinder. When used with single-acting cylinders, one port must be plugged. For double-acting cylinders, either port can be used for "advance" or "return."

Actuation: Lever-operated, detent positioned. **Functions:** The 9508 provides "advance," "hold" and "return" positions with all ports blocked (closed center) in the "hold" position. The 9509 has "advance," "hold" and "return" with tandem center (cylinder ports are blocked, pump remains running). Both valves have "Posi-Check" feature to guard against pressure loss when shifting from "advance" to "hold."

No. 9508 – 4-way/3-position (closed center) manual valve, including subplate for remote mounting. Wt., 2,9 kg.

No. 9509 – Same as 9508, except is tandem center.

CAUTION: To prevent sudden, uncontrolled descent of a load as it is being lowered, use a No. 9596 Load Lowering Valve or No. 9720 Counter Balance Valve (see page 132) in conjunction with the directional valve used in your application.

CAUTION: The Posi-Check® feature will not hold the load when shifted directly A to B-B to A or from hold to A or B.

NOTE: Maximum tank line pressure for remote mounted valves is 35 bar.

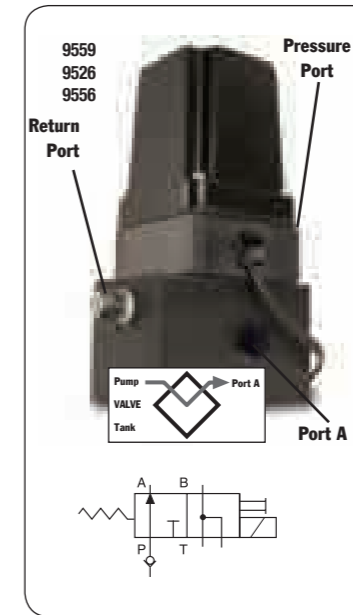

3-WAY/2-POSITION SOLENOID VALVE

Application: Single-acting cylinders.

Actuation: Solenoid operated, 115 volt, 50/60 Hz.

Function: Advances cylinder piston when solenoid is de-energized, and pump is running. When solenoid is energized, oil is directed back through valve "return" port and cylinder piston returns. To place cylinder in "hold" position, pump must be stopped or its flow held at the valve "pressure" port with the solenoid de-energized.

NOTE: Valve is equipped with a 9631 snubber valve in port "A." The line from the "return" port of the valve must be unrestricted (7 bar back pressure maximum) back to the reservoir.

IMPORTANT: A 9580 in-line check valve (see page 123) must be installed in the "pressure" port if the supply pump is not equipped with an outlet check valve.

No. 9559 – 3-way/2-position solenoid valve, 115 volt 50/60 Hz. Includes a remote mounting subplate. Wt., 4,4 kg.

No. 9526 – Same as 9559 except for 230 volt, 50/60 Hz.

No. 9556 – Same as 9559 except for 24 volt, 50/60 Hz.

NOTE: Valves above are shipped without control switch. Use 202777 remote hand switch (see page 106).

Valves

HYDRAULIC REMOTE MOUNTED

700 bar,
3/8" ports
19 l / min max flow

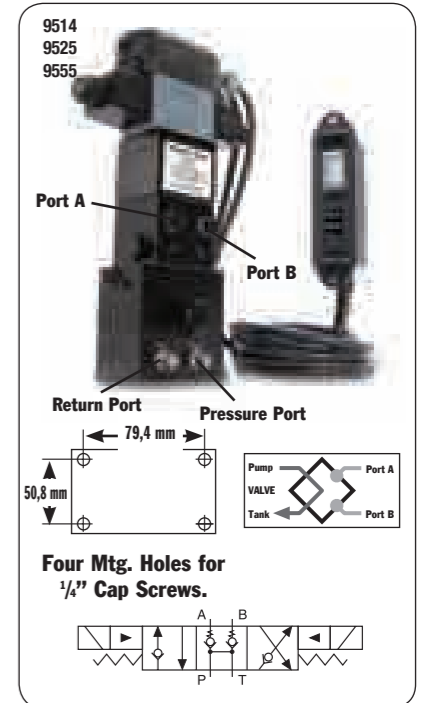

4-way/3-position (tandem center) solenoid valve with Posi-Check®

Application: Double-acting cylinders.

Actuation: Solenoid operated, 115 volt, 50/60 Hz.

Functions: Push button control of "advance," "hold" and "return." The "Posi-Check" feature guards against pressure loss when shifting from "advance" to "hold." With valve in "hold" position, cylinder ports are blocked and oil is directed from pump to reservoir.

NOTE: Do not allow return tank pressure to exceed 35 bar at the valve.

No. 9514 – 4-way/3-position (tandem center) solenoid valve, 115 volt, 50/60 Hz. Remote hand control included. Wt., 4,6 kg.

No. 9525 – Same as 9514 except for 230 volt, 50/60 Hz.

No. 9555 – Same as 9514 except for 24 volt, 50/60 Hz.

NOTE: Consult factory before installing a pressure switch on any of these valves.

HYDRAULIC ACCESSORIES

Valves

HYDRAULIC IN-LINE

700 bar,
19 l / min max flow rate

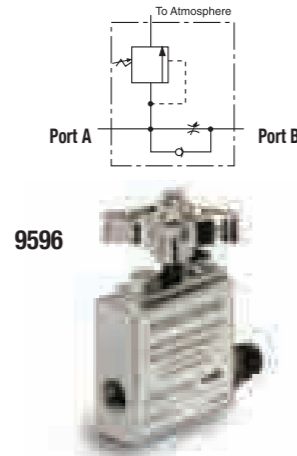

LOAD LOWERING VALVE

Application: Precision metering for controlled cylinder piston return.

Operation: Permits free flow when extending cylinder, built-in pressure relief and "Posi-Check®" locks and holds load in raised position until operator opens valve. May be pre-set to provide consistent metered return, or operator may select rate of return with each actuation. Has 3/8" NPTF ports.

NOTE: Pressure relief valve setting is 830 bar. Operating pressure is 700 bar and max. flow rate is 19 l/min.

No. 9596 - Load lowering valve. Wt., 1 kg.

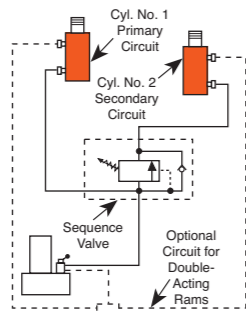
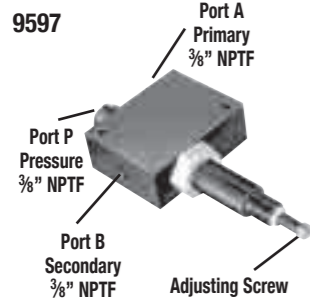

SEQUENCE VALVE

Application: Used when one cylinder in a multi-cylinder application must advance before any other.

Operation: Pump is connected to port "P" and separate cylinders to ports "A" and "B". When pressure is applied to port "P", cylinder "A" advances. Cylinder "B" will not advance until a predetermined pressure setting is reached in cylinder "A". Pressure setting is adjustable from 35 to 550 bar with adjustment screw; factory preset at 70 bar. Has 3/8" NPTF ports.

No. 9597 - Pressure control sequencing valve. Wt., 2,5 kg.

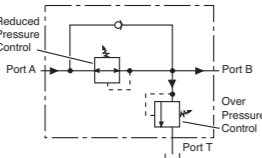

PRESSURE REDUCING VALVE

Application: Provides complete, independent pressure control to two or more clamping systems operated by a single power source.

Operation: Can be used to provide different pressures in various stages of a single system. Virtually zero leakage across valve means each system can be operated by a single continuous pressure source. Adjustable from 70 to 350 bar at outlet port "B" (secondary). Has 1/4" NPTF ports.

No. 9608 - Pressure reducing valve. Wt., 2,6 kg.

9720
9721

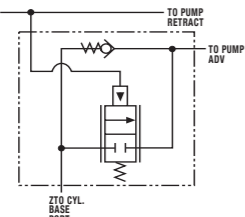

COUNTER BALANCE VALVE

Application: Double-acting cylinders. Provides positive holding and controlled, "chatter-free" lowering of a load.

Operation: Load is raised at flow rate of pump, and held when pump is shut off. When the pump is shifted to "retract", the counter balance valve will continue to hold the load until system pressure exceeds pressure caused by load. The load can then be lowered smoothly to the flow rate of the pump. The counter balance valve is designed to operate with pumps having a high pressure flow rate of

up to 1,9 l/min. and cylinder ratios of 3 to 1.

No. 9720 - Counter balance valve, including two male and two female half two hydraulic hoses, fittings and dust caps. Wt., 4,5 kg.

No. 9721 - Same as 9720, but does not include couplers, hoses, fittings and dust caps. Wt., 4,2 kg.

CAUTION: The 9720 patented counter balance valve has a pilot pressure as high as 210 bar. Because this pressure is applied to the rod end of the cylinder while it is already under load, the system should not be sized for loads greater than 80% of cylinder rated capacity.

CAUTION: To prevent sudden, uncontrolled descent of a load as it is being lowered, use a No. 9596 Load Lowering Valve or No. 9720 Counter Balance Valve in conjunction with the directional valve used in your application. See above, this page.

Shut-off valve

Application: This needle valve permits fine metering of hydraulic oil.

Operation: Can be used for controlling multiple single-acting cylinders.

No. 9575 - Shut off valve with 3/8" NPTF ports. Wt., 0,6 kg.



9575

Check valve

Application: Permits flow of hydraulic oil in one direction only.

Operation: Installs right in hydraulic line.

No. 9580 - Check valve with 3/8" NPTF male ends. Wt., 0,2 kg.



9580

Pilot operated check valve

Application: For use with open or tandem center valves. Permits free flow of fluid in one direction.

Operation: Flow is blocked in opposite direction until pilot oil pressure is applied. This prevents the loss of pressure if the valve is inadvertently shifted or the pump line is broken. Minimum cracking pressure is 4,1 bar. Required pilot pressure is approximately 16% of checked system pressure.

No. 9581 - Pilot operated check valve with 3/8" NPTF ports. Wt., 1,7 kg.

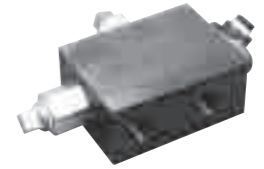

9581

"In-line" pressure relief valve

Application: Single- or double-acting cylinders. For remote locations in a hydraulic circuit where maximum pressure requirements are less than basic overload valve setting in pump.

Operation: Adjustable from 70 to 700 bar. Valve is spring-loaded and direct-acting.

No. 9623 - Pressure relief valve with 3/8" NPTF ports. Wt., 0,9 kg.



9623

Metering valve

Application: For systems using large cylinders or extended lengths of hydraulic hose.

Operation: Controls surges by restricting flow if it exceeds 26,5 l/min. When flow subsides, valve reopens automatically. Has 3/8" NPTF male end to thread into return port of system control valve, and a 3/8" NPTF female end, permitting return hose to be directly connected.

No. 9631 - Metering valve. Wt., 0,1 kg.



9631

"In-line" pressure regulator valve

Application: Single- or double-acting cylinders. Permits adjusting operating pressures at various values below relief valve setting of pump.

Operation: Regulator valve is easily adjusted to maintain pressures between 20 and 700 bar. Maintains a given pressure setting within 3% over repeated cycles. Flow range is 0,3 l/min to 23 l/min.

No. 9633 - In-line pressure regulator valve with two 3/8" NPTF inlet ports, one 1/8" NPTF tank port and 1 m drain line kit. Wt., 0,9 kg.

Simply turn the handle clockwise to increase the pressure setting, counter-clockwise to reduce pressure.

Note: 1 m Drain Line Kit is included.



9633

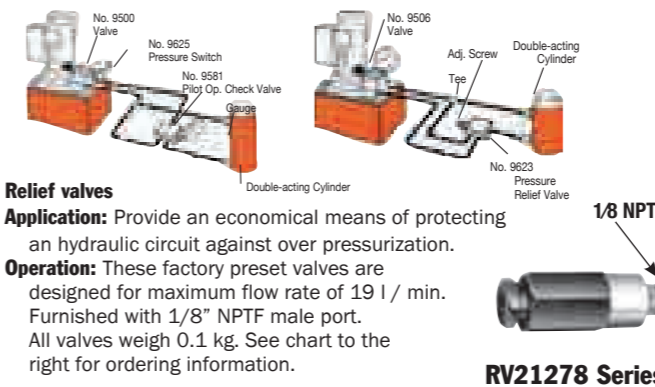

Relief valves

Application: Provide an economical means of protecting an hydraulic circuit against over pressurization.

Operation: These factory preset valves are designed for maximum flow rate of 19 l/min. Furnished with 1/8" NPTF male port. All valves weigh 0.1 kg. See chart to the right for ordering information.

RV21278 Series

Valve Order No.	Pressure Setting (bar)	Valve Order No.	Pressure Setting (bar)
RV21278	697/738	RV21278-52	366/407
RV21278-6	41/44	RV21278-55	386/428
RV21278-10	62/69	RV21278-57	400/442
RV21278-15	103/117	RV21278-60	421/462
RV21278-20	131/152	RV21278-65	455/497
RV21278-28	186/207	RV21278-70	490/531
RV21278-30	207/235	RV21278-75	524/566
RV21278-32	214/228	RV21278-80	559/600
RV21278-35	241/262	RV21278-83	580/621
RV21278-40	283/310	RV21278-86	600/642
RV21278-43	304/331	RV21278-88	614/662
RV21278-48	338/366	RV21278-90	628/669
RV21278-50	352/393		

Preset - Non-Serviceable

NOTE: Care should be exercised to protect workers from hot, pressurized hydraulic oil. Install these valves only in an enclosed or shielded area.

SHOP MAINTENANCE

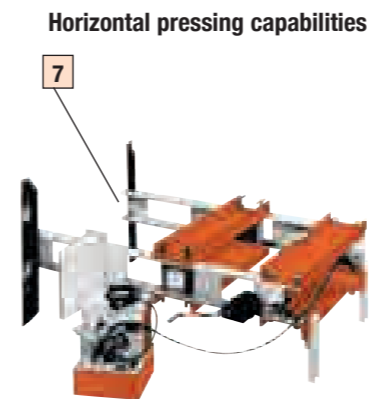
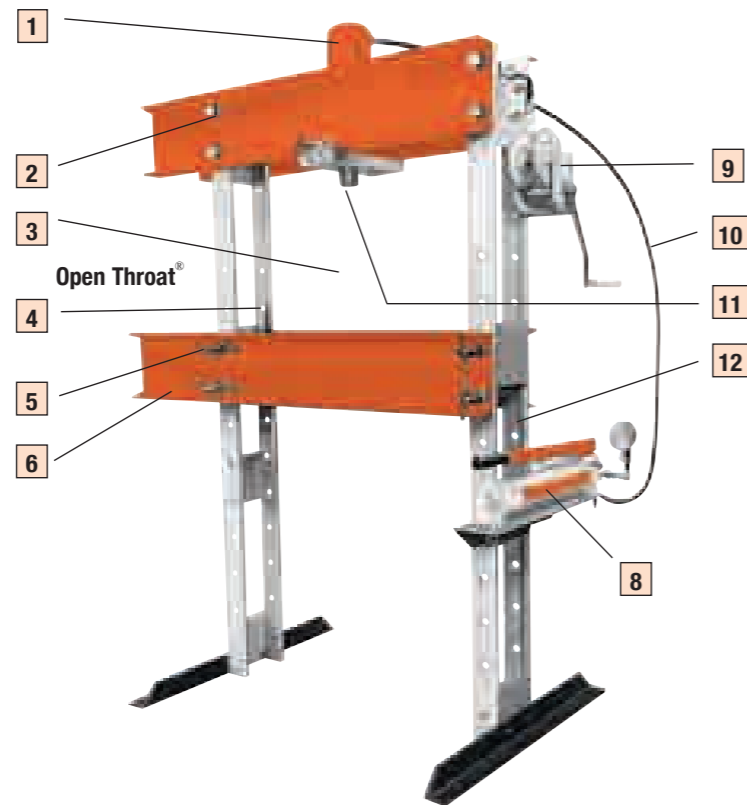

THE UNIQUE BENEFITS OF THE POWER TEAM PRESS

ALL SHOP PRESSES AVAILABLE IN €€

1 2 TO 1 SAFETY FACTOR on hydraulic cylinders and they meet ASME B30.1 standards. Cylinders are easily removed for other applications. Single- or double-acting cylinders are available; built-in relief valve on double-acting cylinders.

2 FULL RATED CAPACITY across width of upper frame, even with workhead moved to one side. (Heavy-duty presses only.)

3 LARGER WORK AREA than most competitors' models.

4 ALIGNMENT LEVER for simple pin replacement after raising or lowering the bed.

5 CLOSE MANUFACTURING TOLERANCE allows even load distribution over four alloy steel pins; not two, like some competitors. (Heavy-duty presses only.)

6 OPEN THROAT® FEATURE on 25 ton press provides

additional work area by mounting cylinder on outside for C-frame advantage.

7 FRAMES CAN BE USED HORIZONTALLY for pressing jobs on extra-long shafts (see photo on next page).

8 ELECTRIC, AIR OR HAND HYDRAULIC PUMPS are available. All are standard Power Team pumps. **CE approved electric pumps are standard on all presses. Externally adjustable relief valve** for precise operator

control of working pressure is standard on all electric pumps except PE10 and PE17 series.

9 ONE-MAN OPERATION for bed adjustment. Winch unit quickly raises or lowers bed to desired height. Self-locking winch mechanism prevents bed from dropping when handle is released.

10 9,5 MM I.D. HOSE on spring return cylinders on heavy-duty presses provides up to six times faster cylinder return than standard 6,4 mm I.D. hose.

11 FAST CYLINDER APPROACH to work provided by 2-speed hand, air or electric pumps.

12 RUGGED UPRIGHTS, 50 percent stronger than channel iron. Four post design means open side for easy loading of long material.

NOTE: Certain features do not apply to Power Team 10 ton, Roll-Bed, or economy presses.

NOTE: Certain press applications may require guarding. Because of the multitude of possible press uses, it is impossible to design a guard that will meet every customer need. The end user must provide their own guarding where the situations dictate.

IMPORTANT SAFETY INFORMATION:

Power Team has protective blankets available which may afford protection from injury to users and others should part breakage occur. Power Team recommends the use of these blankets for all pushing, pulling, pressing, and lifting applications. See page 217 for additional information.

Page
C FRAME... 136



Page
H FRAME... 137
25-55 TON



Page
H FRAME... 140
100-200 TON



Page
H FRAME ... 142
80-200 TON
ROLL BED



Page
ACCESSORIES... 144



Page
... 146
FLOOR CRANES



Page
... 147
LOADROTORS®



Shop Press C FRAME

25 Tons
Press



- Can be bench mounted or on optional pedestal base.
- Bench mount requires less than 1.4 sq. m. of space; on optional pedestal, only 4 sq.m. of floor space is needed.
- "Open Throat" design makes loading and unloading of work easy.
- Cylinder head adjusts to three convenient working positions, providing up to 514 mm of "daylight."
- Hydraulic cylinder delivers a 159 mm stroke, is driven by a P59 two-speed hand pump.
- **Pedestal Base No. 60846** - Provides a stable base for SPM256C. Includes a bracket for mounting the pump on the side of pedestal press. Wt., 34,5 kg.

SPM256C

60846

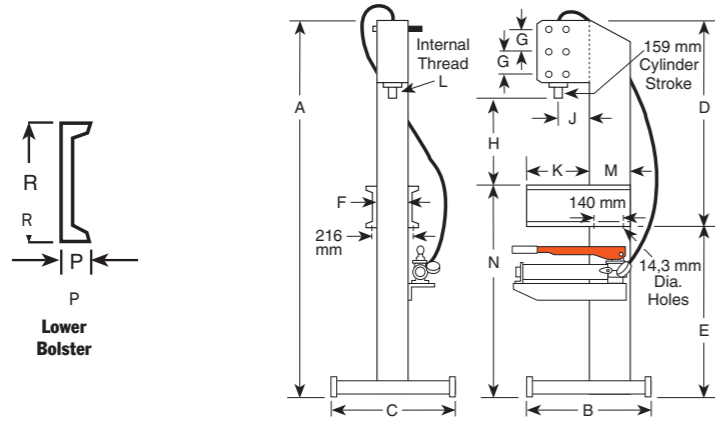

DIMENSIONS

Space	A	B	C	D	E	F	G	H (Cyl. Retracted)	J	K	L	M	N	P	R	Floor
	1.972	622	610	1.057	914	152	127	260, 387, 514	165	318	1 1/2 - 16	203	1.092	51	178	610 x 622

ORDERING INFORMATION

Capacity (tons)	Type Cyl. Used	Stroke (mm)	Cyl. Model	Order No.	Speed** Advance	Pressing	Type Pump	Pump Model	Prod.Wt. (kg)
25	Single-Acting	159	C256C	SPM256C*	3,3 mm/stroke	0,8 mm/stroke	Hand	P59	108

* SPM256C does not include No. 60846 pedestal base.
** Typical performance based on pump specifications. Actual speeds may vary with operating conditions.



Shop Press H FRAME

10 Tons
Bench/Floor Press



SP1010A

SPM1010

- Ideal for small pressing jobs; repairing small motors, armatures, removing and installing gears, bearings, other press-fit parts.
 - Bench press has 391 x 457 mm work area; floor press bed height is adjustable from 127 mm to 1.041 mm with horizontal "daylight" of 553 mm.
 - Choices of power sources: single-speed hand pump, electric/hydraulic or air/hydraulic.
 - Hydraulic gauges, hoses and fittings included.
- PUMP ELECTRICAL SPECIFICATIONS**
PE10 Series - 220 volt, 50 cycle, single phase.

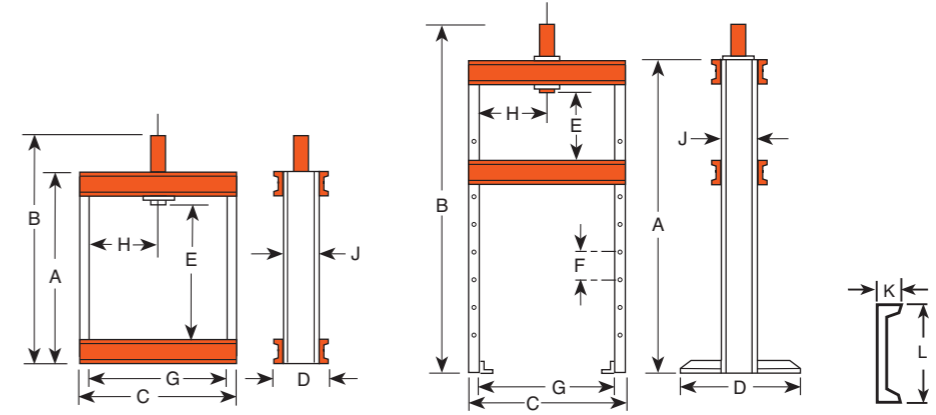

DIMENSIONS

Frame	A (mm)	B (mm)	C (mm)	D (mm)	E (mm)	F (mm)	G (mm)	H (mm)	J (mm)	K (mm)	L (mm)	Bench Space (mm)	Floor Space (mm)
Bench	622	841	641	182	391	--	559	279	102	40	102	182 x 641	--
Floor	1.499	1.718	641	711	127-1.041	152	559	63,5-470*	102	40	102	--	711 x 730

*Lateral head movement

ORDERING INFORMATION

Frame	Cap. (tons)	Type of Cyl. Used	Stroke	Cylinder Model	Order No.	Speed (mm./min.)†††	Advance	Pressing	Type Pump	Pump Model †	Prod. Wt. (kg)
222481 Bench	10	Single-Acting	257	C1010C	SPM1010	1,5 mm/stroke			Hand	P55	41,2
222480 Floor	10	Single-Acting	257	C1010C	SPH1010	1,5 mm/stroke			Hand	P55	77,5
222480 Floor	10	Single-Acting	257	C1010C	SPE1010	55,7	5,1		Elec. ††	PE172-E220	79,3
222480 Floor	10	Single-Acting	257	C1010C	SP1010A	93,7	7,6		Air	PA9H	78,1
222480 Floor	10	Double-Acting	254	RD1010	SPE1010D	55,7	5,1		Elec. ††	PE174-E220	87,0

† Optional air/hydraulic pumps available on request.
†† "Advance" position holds pressure with motor shut off. "Return" position advances cylinder with motor running and returns cylinder with motor shut off.
††† Typical performance based on 7 bar and 700 bar pump specifications. Actual speeds may vary with operating conditions.

PRESS ACCESSORIES

Page 144-145

Press H FRAME

Open Throat & Economy Press 25 Ton Presses

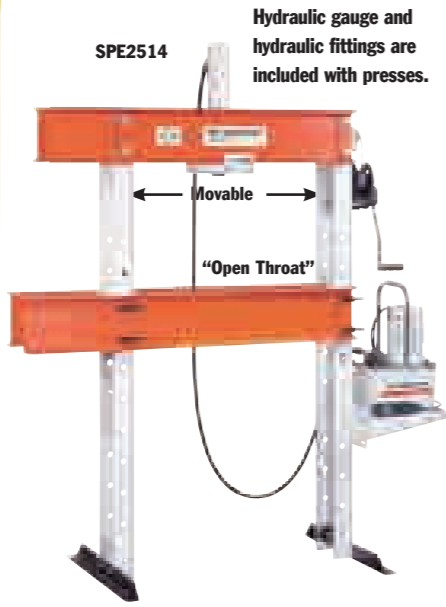

Hydraulic gauge and hydraulic fittings are included with presses.

SHOP EQUIPMENT

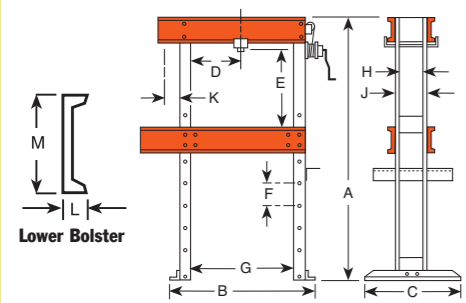

Open Throat feature enables cylinder to be mounted on outside of press frame for fast bearing removal and more.



OPEN THROAT PRESSES

- Design permits use as both "H" frame and "C" frame press; cylinder can be mounted on frame extension to handle jobs which won't fit between uprights.
- Open throat press models are also available with remote control to enable the operator to view work from all sides with fingertip control of cylinder piston travel.
- Off-center pressing loads of full capacity can be applied across entire width of frame.

ECONOMY PRESSES

- Rugged, yet reasonably priced. Handles many "big press" tasks, and perfect for many of the "in-between" jobs you see almost daily. (Note: stroke length limited to 159 mm on economy models.)

FEATURES OF BOTH OPEN THROAT AND ECONOMY PRESSES

- Press bed height easily adjustable with winch. Bed will not drop when handle is released.
- Choice of power sources for rapid cylinder advance: two-speed hydraulic hand pump, electric/hydraulic or air/hydraulic.

PUMP ELECTRICAL SPECIFICATIONS

PE17 Series – 0,37 KW, 220 volt, 50 cycle, single phase.

- Full off-center pressing at full rated capacity across width of upper frame without buckling or bending.
- Maximum "daylight" is 1067 x 914 mm, making positioning of even bulky work pieces easy.
- Height of press bed is easily adjusted with winch; friction brake prevents bed from dropping and handle from spinning upon release.
- Presses with single-acting cylinder offer choice of 2-speed hand operated, electric/hydraulic, or air/hydraulic pump. Models with double-acting cylinder have an electric/hydraulic pump.
- Press models equipped with remote control enable operator to view work from all sides with fingertip control of cylinder piston travel.
- Press can be used horizontally for special applications with user-supplied support legs.

PUMP ELECTRICAL SPECIFICATIONS

PE17 Series – 0,4 Kw, 220 volt, 50 cycle, single phase.



Press H FRAME

55 Ton Presses



Hydraulic gauge and hydraulic fittings are included with presses.

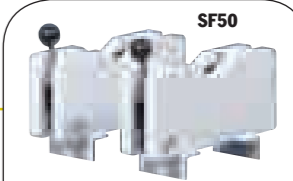

No. SF50 – Straightening fixtures for use with 55-ton shop or 80-ton Roll-Bed® presses (2 ea.). Wt., 47,2 kg. **Not part of press, order separately.**

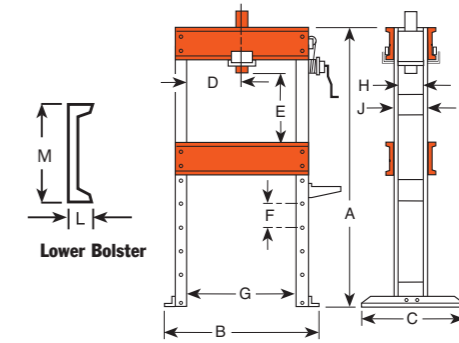

SHOP EQUIPMENT

DIMENSIONS

A (mm)	B (mm)	C (mm)	D* (mm)	E (mm)	F (mm)	G (mm)	H (mm)	J (mm)	K (mm)	L (mm)	M (mm)	Floor Space (mm)
1.727	1.092	711	76-737	175-1.102	114	813	140	165	178	64	203	1.092 x 711

*Lateral head movement

ORDERING INFORMATION

Cap. (tons)	Type of Cylinder Used	Stroke (mm)	Cylinder Model	Order No.	Speed (mm/min.)††	Type Pump	Valve Type	Pump‡ Model	Prod.Wt. (kg)
"Open Throat" presses									
25	Single-Acting	362	C2514C	SPA2514	249	Air	2-Way Foot	PA6	309
25	Single-Acting	362	C2514C	SPM2514	12,4 mm/stroke	Hand	Load - Release	P159	314
25	Single-Acting	362	C2514C	SPE2514	1.184	Elec.	2-Way††	PE172-E220	301
25	Single-Acting	362	C2514C	SPE2514S	1.321	Elec.	3-Way†	PE172S-E220	344
25	Double-Acting	362	RD2514	SPE2514DS	1.321	Elec.	4-Way†	PE174S-E220	357
"Economy" presses									
25	Single-Acting	159	C256C	SPA256	249	Air	2-Way Foot	PA6	197
25	Single-Acting	159	C256C	SPM256	3,0 mm/stroke	Hand	Load - Release	P59	205
25	Single-Acting	159	C256C	SPE256	1.184	Elec.	2-Way††	PE172-E220	210

† Solenoid valve with 12 volt remote control hand switch.

†† Holds pressure with motor shut off. Also has an automatic dump setting. Furnished with a 3.1m remote motor control.

††† Typical performance based on 7 bar and 700 bar pump specifications. Actual speeds may vary under operating conditions.

‡ Pump standard with press. Other Power Team pumps can be substituted.

dBA at idle and 700 bar: PE172-67/81 dBA; measured at 0,9 m distance, all sides.

DIMENSIONS

A (mm)	B (mm)	C (mm)	D* (mm)	E (mm)	F (mm)	G (mm)	H (mm)	J (mm)	L (mm)	M (mm)	Floor Space (mm)
1.829	1.232	914	83-832	152-1.067	152	914	171	203	76	305	1.232 x 914

*Lateral head movement

ORDERING INFORMATION

Cap. (tons)†	Type of Cylinder Used	Stroke (mm)	Cylinder Model	Order No.	Speed (mm/min.)††	Type Pump	Valve Type	Pump‡ Model	Prod.Wt. (kg)
55	Single-Acting	159	C556C	SPA556	114	Air	2-Way Foot	PA6	318
55	Single-Acting	159	C556C	SPM556	5,8 mm/stroke	Hand	Load - Release	P159	323
55	Single-Acting	337	C5513C	SPM5513	18,9 mm/stroke	Hand	2-Way	P460	435
55	Single-Acting	159	C556C	SPE556	551	Elec.	2-Way††	PE172-E220	333
55	Single-Acting	337	C5513C	SPE5513	551	Elec.	2-Way††	PE172-E220	444
55	Single-Acting	337	C5513C	SPE5513S	620	Elec.	3-Way†	PE172S-E220	478
55	Double-Acting	333	RD5513	SPE5513D	551	Elec.	4-Way	PE174-E220	450
55	Double-Acting	333	RD5513	SPE5513DS	1.679	Elec.	4-Way†	PE554S-E220	505

* Frame is shipped assembled.

† Solenoid valve with 24 volt remote control hand switch.

†† Holds pressure with motor shut off. Also has an automatic dump setting. Furnished with a 3,1 m remote motor control.

††† Typical performance based on 7 bar and 700 bar pump specifications. Actual speeds may vary with operating conditions.

‡ Pump standard with press. Other Power Team pumps can be substituted. dBA at idle and 700 bar: PE172-67/81; measured at 0,9 m distance, all sides.

PRESS ACCESSORIES

Page 144-145

H Frame Presses

100 Ton Presses

- Cylinder workhead glides across upper frame on rollers, locks in place for off-center pressing jobs. May be used horizontally for special pressing applications with user-supplied supports.
- Press bed is raised and lowered by winch which locks in place for insertion of bed retaining pins. Upper bolster can be lowered 203 mm for convenient positioning on repetitive jobs.
- Generous "daylight" of 1.067 x 1.270 mm accommodates bulky work pieces, uprights are placed for easy side entry of bars or shafts for straightening or bending.
- Choice of single- or double-acting cylinder. Hydraulic pump options include: 2-speed hand pump with large 7,6 l reservoir, PE172 electric/hydraulic pump or "PQ" series "Quiet" electric/hydraulic pump with low noise level.



SPE10013DS
Hydraulic gauge and hydraulic fittings are included with presses.

PUMP ELECTRICAL SPECIFICATIONS

- PE17 Series** – 0,4 KW, 220 volt, 50 cycle, single phase.
- PQ120 Series** – 2,2 kW, 380 V, 50 cycle, three phase.

SF150



No. SF150 – Straightening fixtures for use with 100-ton shop press and 100-, 150-, and 200-ton RollBed® presses (2 ea.). Wt., 89 kg. **Not part of press, order separately.**

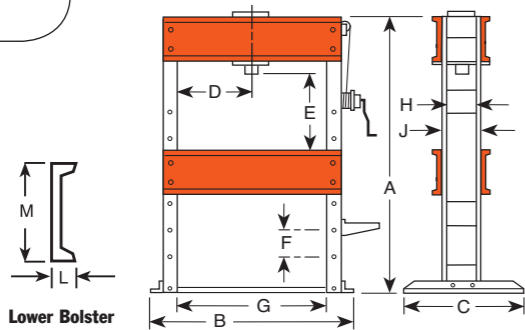

DIMENSIONS

A (mm)	B (mm)	C (mm)	D* (mm)	E (mm)	F (mm)	G (mm)	H (mm)	J (mm)	L (mm)	M (mm)	Floor Space (mm)
1.962	1.626	914	178-1.092	51-1.067	203	1.270	203	254	86	381	914 x 1.988

*Lateral head movement

ORDERING INFORMATION

Cap. (tons)†	Type of Cyl. Used	Stroke (mm)	Cylinder Model	Order No.	Speed (mm/min.)††	Advance	Pressing	Type Pump	Valve Type	Pump‡ Model	Prod. Wt. (kg)
100	Single-Acting	260	C10010C	SPM10010	9,0 mm/stroke	0,3 mm/stroke	Hand	3-way	3-way	P460	769
100	Single-Acting	260	C10010C	SPE10010	889	74	Elec.	3-way	3-way	PE552-E220	813
100	Single-Acting	260	C10010C	SPE10010R	292	20	Elec.	2-way	2-way	PE172-E220	766
100	Double-Acting	333	RD10013	SPE10013DS	889	147	Elec.	4-way*	4-way*	PQ1204S-E380	854

† Frame is shipped assembled. *Solenoid valve with 24 volt remote control hand switch.
 †† Typical performance based on 7 bar and 700 bar pump specifications. Actual speeds may vary under operating conditions.
 ‡ Pump standard with press. Other Power Team pumps can be substituted.
 dBA at idle and 700 bar: PE172—67/81; PQ120—73/78. Measured at 0,9 m distance, all sides.

H Frame Presses

150-200 Ton Presses

- Standing 2,3 m tall, these giants handle the really big jobs. May be used horizontally for special pressing applications with user-supplied supports.
- Workhead has wide horizontal travel; rugged press frame withstands load of rated capacity across full width of frame.
- Winch mechanism provides easy positioning of press bed, locks in place for insertion of retaining pins. Upper bolster can be lowered 279 mm for convenient positioning on repetitive jobs.
- Uprights are placed for easy side entry of bars or shafts for straightening or bending.
- Fast cylinder approach is provided by PQ1204S "Quiet" electric/hydraulic pump. Has remote control hand switch, enabling operator to view work from all sides with fingertip control of cylinder piston travel.



SPE20013DS
Hydraulic gauge and hydraulic fittings are included with presses.

PUMP ELECTRICAL SPECIFICATIONS

- PQ120 Series** – 2,24 KW, 380 volt, 50 cycle, three phase.

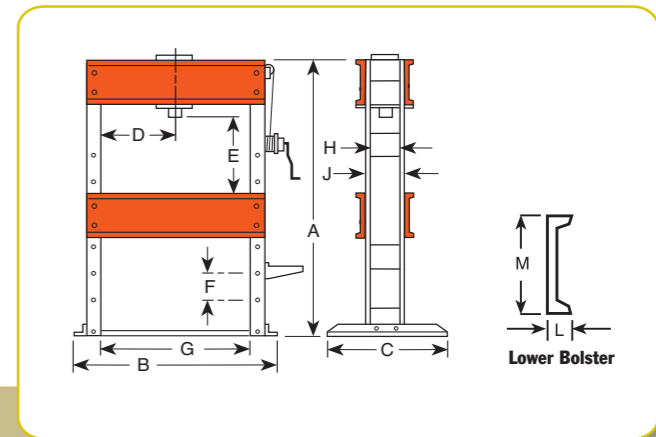

DIMENSIONS

A (mm)	B (mm)	C (mm)	D* (mm)	E (mm)	F (mm)	G (mm)	H (mm)	J (mm)	L (mm)	M (mm)	Floor Space (mm)
2.286	1.803	1.118	279-991	228-1.111	279	1.270	318	381	105	457	1.117 x 1.803

*Lateral head movement

ORDERING INFORMATION

Capacity (tons)†	Type of Cylinder Used	Stroke (mm)	Cylinder Model	Order No.	Speed (mm/min.)††	Advance	Pressing	Type Pump	Valve Type	Pump Model***	Prod. Wt. (kg)
150	Double-Acting	333	RD15013	SPE15013DS	610	99	Electric	4-way**	4-way**	PQ1204S-E380	1.366
200	Double-Acting	333	RD20013	SPE20013DS	457	74	Electric	4-way**	4-way**	PQ1204S-E380	1.484

† Frame is shipped assembled.
 †† Typical performance based on 7 bar and 700 bar pump specifications. Actual speeds may vary under operating conditions.
 ** Solenoid valve with 24 volt remote control hand switch.
 *** Pump standard with press. Other Power Team pumps can be substituted. dBA at idle and 700 bar: 73/78, measured at 0,9 m foot distance, all sides.

PRESS ACCESSORIES

Page 144-145

Roll-Bed® Press

80-200 Ton
H Frame



Heavy-Duty Straightening Fixtures

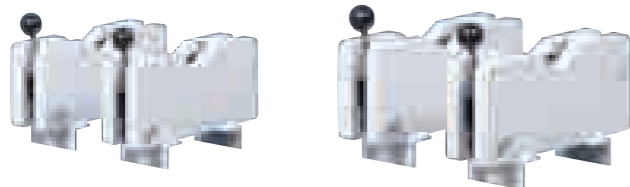

No. SF50 – Fixtures for use with 80-ton Roll-Bed® presses or 55-ton heavy-duty shop presses. (2 ea.). Wt. 47,2 kg. **Not part of press, order separately.**

No. SF150 – Fixtures for use with 100-, 150- and 200-ton Roll-Bed® presses and 100-ton shop presses only (1 pr.). Wt. 89 kg. **Not part of press, order separately.**

- The original, patented Roll-Bed® design. Bed rolls out for easy loading and unloading with a crane or other lifting device.
- Movable workhead glides easily side-to-side for full off-center load capacity across width of upper frame.
- “Daylight” is 1.283 x 1.524 mm for 80- and 100-ton models; 1.302 x 1.625 mm on 150- and 200-ton presses.
- Fast approach of double-acting, 334 mm stroke cylinder is provided by PQ1204S “Quiet” electric/ hydraulic pump with remote control hand switch. Operator can view work from all sides with fingertip control of cylinder piston travel.

PRESS FEATURES:

- **Roll-Bed® design** – Bed glides in or out on bearings to make loading and unloading fast and easy.
- Adjustable lower bed width – For secure balancing and centering of heavy jobs. Loosen adjusting bolts to adjust bed from 102 to more than 686 mm. See dimension “H.”
- **Movable workhead** – For off-center pressing jobs, workhead moves on bearings across upper bolster. Presses can be used at full capacity, regardless of where workhead is placed.
- **Lifting mechanism** – Simply turn crank handle to raise or lower upper bolster. Screw mechanism raises or lowers both sides evenly (a heavy-duty 1/2” drill motor can replace handle for automatic adjustment). Four locking pins hold bolster in place for pressing.

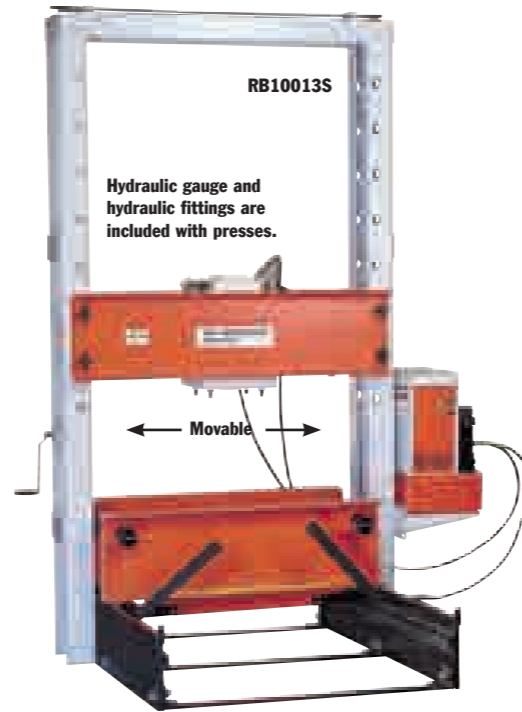

Hydraulic gauge and hydraulic fittings are included with presses.

Movable

- **Optional heavy-duty straightening fixtures** – Make straightening jobs easy and accurate to within 0.1 mm! Rollers are ball bearing mounted and handle raises or lowers for easy turning of the work.

PUMP ELECTRICAL SPECIFICATIONS

PQ120 Series – 2,24 KW, 380 volt, 50 cycle, three phase.

NOTE: Different voltage and valve options can be obtained by substituting certain PA, PE or PQ series pumps. Consult the factory.

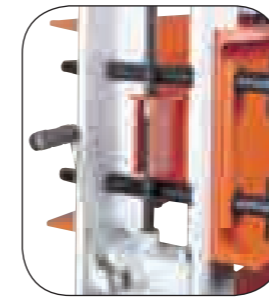

Lifting screw and locking pins make bolster raising a one-man job.



Bearings make bed positioning smooth and easy.



Lever lowers bed for pressing, raises it for rolling.



Cylinder is easily moved across width of upper bolster.

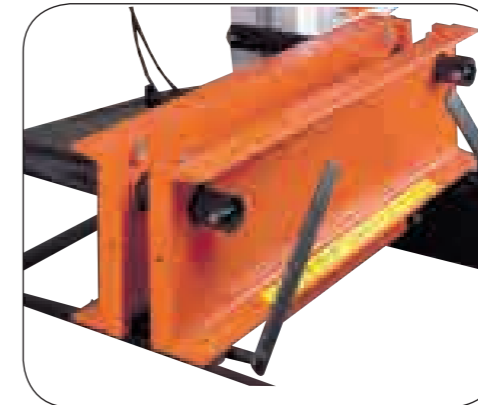

Width adjusts from 102 mm to over 686 mm; is secured with locking bolts.

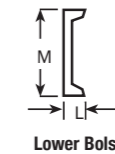

Lower Bolster

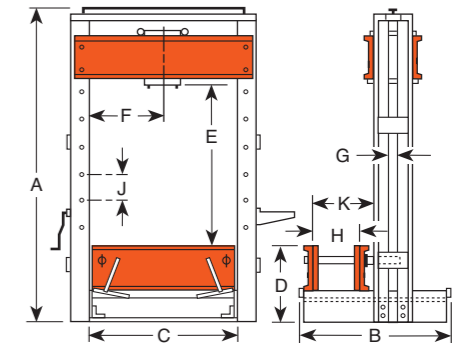

DIMENSIONS

Cap (Tons)	A (mm)	B (mm)	C (mm)	D (mm)	E (mm)	F (mm)	G (mm)	H (mm)	J (mm)	K (mm)	L (mm)	M (mm)	Floor Space (mm)
80	2.861	1.632	1.283	686	305-1.524	368-914	76,2	102-692	203	927	86	381	1.632-1.537
100	2.861	1.632	1.283	686	305-1.524	368-914	76,2	102-692	203	927	86	381	1.632-1.537
150	3.131	1.734	1.302	762	229-1.626	352-949	76,2	102-689	279	946	105	457	1.734-1.607
200	3.131	1.734	1.302	762	229-1.626	352-949	76,2	102-689	279	946	105	457	1.734-1.607

ORDERING INFORMATION

Capacity (tons)†	Type of Cylinder Used	Stroke (mm)	Cylinder Model	Order No.	Speed (mm/min.)††	Type Pump	Valve Type	Pump‡ Model	Prod. Wt. (kg)
80	Double Acting	333	RD8013	RB8013S	1.168	190	Elec.	4-way* PQ1204S-E380	1.307
100	Double Acting	333	RD10013	RB10013S	889	147	Elec.	4-way* PQ1204S-E380	1.334
150	Double Acting	333	RD15013	RB15013S	610	99	Elec.	4-way* PQ1204S-E380	2.019
200	Double Acting	333	RD20013	RB20013S	457	74	Elec.	4-way* PQ1204S-E380	2.059

* Solenoid valve with 24 volt remote control hand switch.

† Frame is shipped assembled.

‡ Pump standard with press. Other Power Team pumps can be substituted. dBA at idle and 700 bar: PQ120-73/78; measured at 0,9 m distance, all sides.

†† Typical performance based on 7 bar and 700 bar pump specifications. Actual speeds may vary with operating conditions.

PRESS ACCESSORIES

Page 144-145

Shop Press ACCESSORIES

Shop Press ACCESSORIES

Rubber Tire Removing/Installing set

Now an easy way to press solid rubber tires. The TPP200 uses plates instead of combination rings to press a rim from an old tire into a new one. Plates are stacked so none is more than 50,8 mm smaller than the one under it to keep the plates from bending. They can be used on any Power Team press with 55-ton capacity or more. NOTE: Many tires require 100 tons of force or more, depending on tire size and condition. These plates withstand max. force of 150 tons.

No. TPP200 – Tire press plate set. Includes 13 press plates, spacer pushing adapter and press bed plate. For use on solid rubber tires from 102 mm to 451 mm I.D.



Order No.	Set No. TPP200 Tire Size I.D. (mm)	Plate O.D. (mm)
TPP1	102	98,4
TPP2	127	123,8
TPP3	152,159	149,2
TPP4	165	161,9
TPP5	203	200
TPP6	254	250,8
TPP7	267	263,5
TPP8	286	282,6
TPP9	305,308	301,6
TPP10	356	352,4
TPP11	381	377,8
TPP12	406	403,2
TPP13	451	447,7
TPS6	Spacer/Pushing Adapter	82,6 x 152,4
TBP1622	Bed Plate	406 x 559 x 51

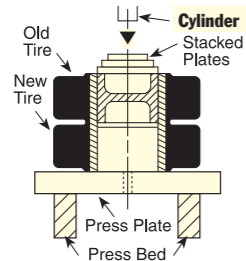

Pressing rim into new tire on Power Team Press.

Press Accessory Kit

Make your Power Team press even more versatile with one of these accessory sets. These sets will eliminate makeshift set-ups. Many of these items can be used with pullers you already have.



PRESS ACCESSORIES, "V" BLOCKS & THREADED ADAPTERS

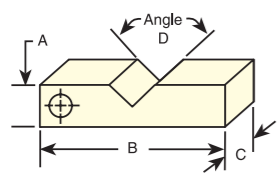

Order No.	Width A (mm)	Length B (mm)	Thick C (mm)	Angle D
1890	50,8	228,6	31,8	120°
1891	63,5	292,1	44,5	120°
1892	88,9	355,6	50,8	120°
1893	127	355,6	38,1	120°
207395	146,1	584,2	63,5	120°

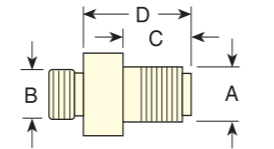

Adapter No.	A	B	C (mm)	D (mm)
38597	1-8	1-8	19,1	33,3
38953	1 1/4 - 7	1 1/2 - 16	69,9	111,1
37368	1 5/8 - 5 1/2	--	42,9	63,5
43562	2 1/4 - 12	--	57,2	76,2
38954	1 5/8 - 5 1/2	1 1/2 - 8	82,6	106,4
43563	2 1/4 - 12	2 3/4 - 12	57,2	81
46070	2 1/4 - 12	2 - 4 1/2	57,2	81

ORDERING INFORMATION

Use	With	A V-Throat Order	B Press	C Pushing ▲	D Pushing ▲	E Pushing	F Threaded Adapter V-Pushing Single-	G Double-
10 Ton	SPA10	1888	1890 (Pr.)	201923 12,7 mm dia. shank	201454 19 mm dia. shank	34806	Included in Set 38597 38597	—
25 Ton	SPA25	1889	1891 (Pr.)	34510 19 mm dia. shank	34511 25,4 mm dia. shank	34807	Included in Set 38953 38953	—
55 Ton	SPA55	—	1892 (Pr.)	34755 25,4 mm dia. shank	34756 31,8 mm dia. shank	34808	Not Included Order Separately 37368 38954	—
80/100 Ton	SPA100	—	1893 ** (Pr.)	—	—	36469 43562 43563	Not Included Order Separately 43562 43563 46070 *** 46070	21332
150/200 Ton	SPA200	—	207395 (Pr.)	—	44458 57,1 mm dia. shank	44457	None*	—

* Pushing adapters thread directly into RD15013 and RD20013 cylinders.

** V-blocks, No. 1893, are recommended for use with 80-ton Roll-Bed press. Not recommended for use with 100-ton Roll-Bed.

*** For 80-ton Roll-Bed press.

NOTE: Individual press accessories may be ordered separately.



CAUTION: Pushing adapters are designed for use with specific shaft sizes, and depending on the condition of the shaft ends, the adapter may not withstand the full press tonnage. Always use a protective blanket or other suitable guard when pressing.

Mobile Floor Cranes

1000- 2000 kg



U.S. Patent No. 3,367,512
Patented 1969 Canada

1000 kg and 2000 kg capacity with space-saving fold-away feature

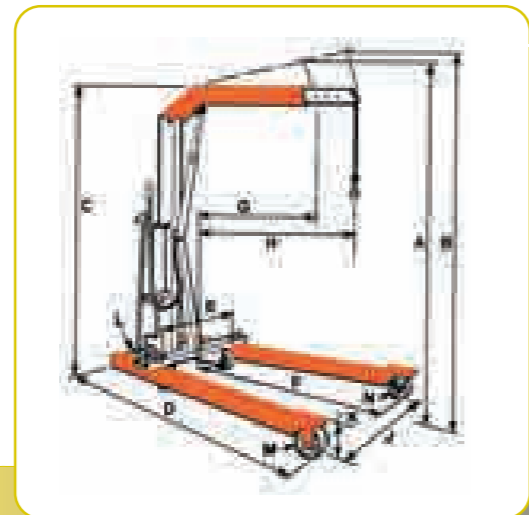

- Adjustable legs spread to clear obstacles, telescoping boom for extra reach. Rugged construction, reliable hydraulics.
- Boom collapses completely and legs fold for compact storage.
- 2-speed hydraulic hand pump provides fast boom travel and precise operator controlled descent.
- Roller bearing wheels and a steering dolly provide ease of mobility. Lifting chain is included.

No. FC4400 - 2000 kg cap. crane with fold-away feature, adj. leg spread, lifting chain and 2-speed hand pump. Wt. 293 kg.

DIMENSIONS

	FC2200*	FC4400*
Cap., boom ret. (kg)	1.000	2.000
Cap., boom ext. (kg)	750	1.500
A Max. boom hgt., ret (mm)	2.718	2.819
B Max. boom hgt., ext.(mm)	2.972	3.099
C Overall hgt., boom horiz.(mm)	2.032	2.083
D Overall length (mm)	2.108	2.261
E Min. throat width (mm)	610	635
F Inside leg length (mm)	1.372	1.461
G Eff. boom reach -ret.(mm)	838	902
H Eff. boom reach -ext. (mm)	1.219	1.238
J Inside leg width (mm)	610-914-1.219	660-1.016-1.333
(3 -position)	(3 -position)	
K Leg height (mm)	203	241
L Dolly wheel diameter(mm)	127	127
M Wheel diameter (mm)	152	203
N Caster diameter (mm)	152	152
space, folded (mm)	686 x 965	787 x 1.067
Height, folded (mm)	2.007	2.184

* Frame shipped unassembled.

Load-Rotors® TILTERS

908-2720 kg

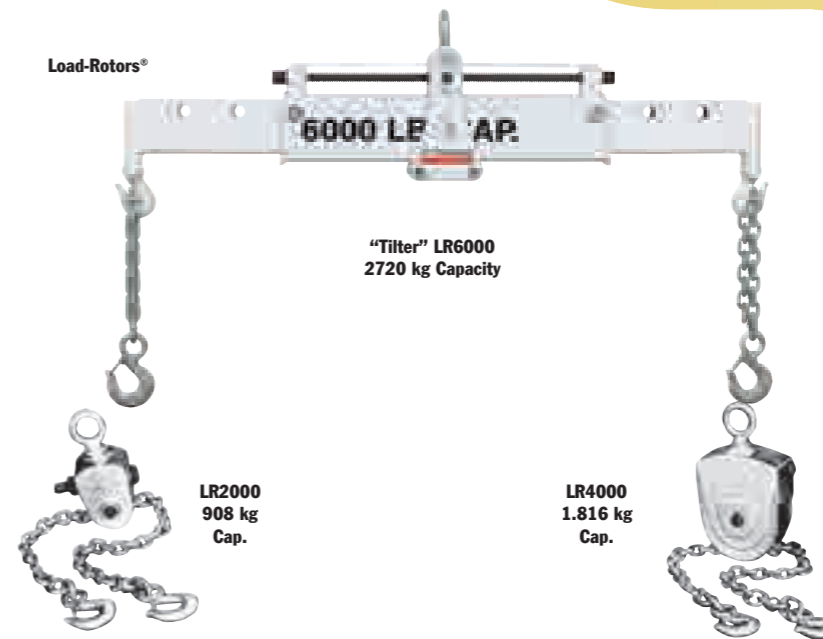

- For lifting or positioning components, Power Team's heavy duty lifting slings are just right.
- The heavy-duty Load-Rotors®, when used with a crane or hoist, greatly reduce time and effort.
- A self-locking worm and gear set in the Load-Rotor® head permits rapid angle adjustment of the component being handled.
- Whenever you have big, heavy components to move or position, nothing helps you get the job done easier and faster than the 2.720 kg "Tilter."

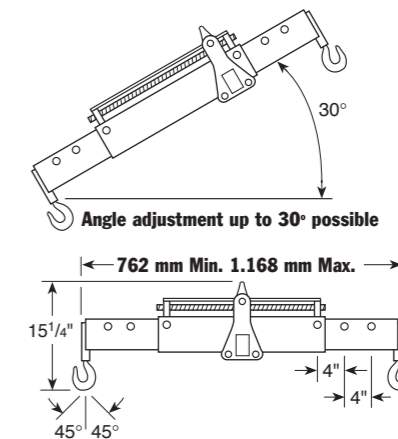

The working length is adjustable in three positions from 762 mm to 1.168 mm. Maximum chain angle is 45°.

ORDERING INFORMATION

Capacity kg	Order No.	Chain Size (mm)	Chain Lg. W/ Swivel Hooks (mm)	Lifting Eye Opening (mm)	Hex Drive End (in)	Gear Ratio	Product Wt. (kg)
908	LR2000	6,4	1.422	31,8	5/8	34:1	4,1
1.816	LR4000	7,9	1.650	44,5	5/8	82:1	10,4
2.720	LR6000	7,9	1.650	41,3	5/8	82:1	33,1

JACKS



Page
... **154**
TELESCOPING JACKS
BOTTLE JACKS
6-15 Ton



Page
... **155**
SIDEWINDER JACKS
5-20 Ton



Page
BOTTLE JACKS... 150
2-110 Ton



Page
... **156**
MAINTENANCE SETS



Page
... **151**
LOW PROFILE BOTTLE JACKS
12-30 Ton



Page
... **157**
POST TENSION JACKS
20-30 Ton



Page
... **152**
TOE JACKS
5 1/2 - 27 1/2 Ton



Page
... **158-159**
INFLATABLE JACKS
1-74 Ton



Page
ECONOMY TOE JACKS... 153
2-10 Ton



Page
... **160-163**
PORTABLE HIGH TONNAGE RAILROAD JACKS 55-150 Ton



Series Description	Pg	STROKE (MM)																																	
		1,1 Ton	2 Ton	3 Ton	3,6 Ton	5 Ton	5,5 Ton	6 Ton	7 Ton	8 Ton	10 Ton	11 Ton	12 Ton	13 Ton	15 Ton	20 Ton	22 Ton	23,8 Ton	27,5 Ton	30 Ton	33 Ton	34 Ton	46,3 Ton	50 Ton	55 Ton	60 Ton	74,6 Ton	100 Ton	110 Ton	150 Ton					
Bottle Jack Std	140		114	114		120				120				149		156				159	156					171									
Bottle Jack Low Profile	141													95						86													155		
Toe Jacks Std	142						210								235									233											
Toe Jacks Economy	143		124			124					149																								
Bottle Jacks Telescoping	144							305						262		254	181																		
Bottle Jacks Sidewinder	145					19/38					30									30															
SJ Post Tension/Stressing Jacks	147																			216/254															
IJ Inflatable Jacks	148	68			119					160			224											305											
PL High Tonnage Portable Jack RR	150																																	355	521
PM High Tonnage Portable Jack	152																																	355	333

Bottle Jacks

2-110 Ton
Portable
hydraulic power

Industrial lifting and pushing
applications.

JACKS



- Choose from this complete line of premium-quality, standard bottle jacks. Ideal for use in any number of industrial lifting and pushing applications.
- The 9110B, 9015B, 9022B and 9033B feature a beveled base which allows the jack to "follow" the load, reducing the chance of dangerous side-loading.
- Many jacks feature screw extensions and all can be used in the vertical, angled or horizontal positions.
- Serrated or contoured saddles help stabilize the load for a safer lift.
- All jacks meet ASME B30.1 standards and carry the Power Team Marathon Lifetime Warranty.
- 110-ton jack features dual pumps for time-saving two-speed operation.

ORDERING INFORMATION

Cap. Tons	Stroke (mm)	Order Number	Retracted Height (mm)	Length of Screw (mm)	Height w/Screw Ext. (mm)	No. Pump Strokes to Ext. Piston completely	Saddle Dia. (mm)	Base Size (mm)	Pump Handle Length (mm)	Handle Effort at Rated Cap. (kg)	Carry Handle	Metric tons at 700 (bar)	Product Weight (kg)
2	114	9002A	181	49	344	5	25	110x65	311	34	No	1,8	2,2
3	114	9003A	191	60	365	10	29	114x72	489	20,4	No	2,7	2,6
5	121	9005A	200	70	391	12	35	132x76	545	24,9	No	4,5	3,6
8	121	9008A	200	70	391	18	38	152x89	605	34	No	7,3	5,5
12	149	9112A	241	79	470	26	48	165x106	605	27,2	Yes	10,9	7,9
15	156	9015B	230	110	495	27	60	130x140†	700	40,8	No	13,6	8,3
20	159	9120A	270	40	429	22	51	183x129	800	31,7	Yes	18,1	12,9
22	156	9022B	240	110	505	36	60	165x160†	700	40,8	Yes	20,0	10,7
30	159	9030A	279	--	438	35	60	192x141	1.000	22,7	Yes	27,2	18,7
33	143	9033B	240	100	483	56	65	184x176†	700	39,9	No	29,9	14,5
50	171	9050A	305	--	476	35	76	237x187	1.000	38,6	Yes	45,4	35,4
110	156	9110B	300	--	456	40/160‡	111	339x291	700	35,8	Yes	99,8	70

† Comes with a Beveled Base

‡ 2 Speed: Rapid advance≈40 strokes; Lift mode≈160 strokes

Low Profile BOTTLE JACKS

12, 20 & 30 Ton

The right choice for those
lower clearance jobs.



- All the quality, features and lifting capacity of the standard jacks in short form. The 12-ton and 20-ton models feature screw extensions for added versatility.
- All jacks meet ASME B30.1 standards and carry the Power Team Marathon Lifetime Warranty.
- All jacks operate both vertically and horizontally for use in a variety of lifting, pushing and spreading applications.

ORDERING INFORMATION

Product Cap. Tons	Stroke (mm)	Order Number	Retracted Height (mm)	Length of Screw (mm)	Height w/Screw Ext. (mm)	No. Pump Strokes to Ext. Piston	Saddle Dia. (mm)	Base Size (mm)	Pump Handle Length (mm)	Handle Effort at Rated Cap. (kg)	Carry Handle	Metric tons at 700 (bar)	Weight (kg)
12	95	9012A	171	76	343	26	48	165x106	605	27	Yes	10,9	6,4
20	86	9020A	181	40	305	22	51	183x129	800	32	Yes	18,1	10,1
30	79	9130A	181	--	260	35	60	192x141	1.000	23	Yes	27,2	13,7

‡ 2 Speed: Rapid advance≈40 strokes; Lift mode≈160 stroke

JACKS

Toe Jacks

5.5, 11 & 27.5 Ton

Get under equipment with only 27 mm of ground clearance.



ASME B30.1

- With lifting points on the toe and on the top, these extremely rugged jacks are ideal for machine lifting, rigging, lift truck service and much more.
- Choose from 5.5-ton, 11-ton, and now, an amazing 27.5-ton lifting capacity.
- All jacks operate both vertically and horizontally.
- Base, toe and pumping assembly swivel independently, allowing the jack to work in confined areas.



The J Series Toe Jack is an extremely rugged jack used here for lift truck service.

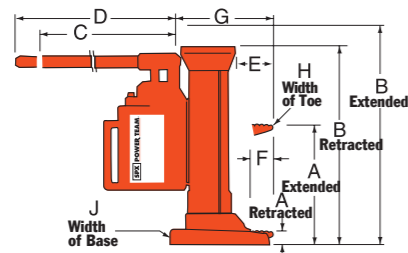

DIMENSIONS

Order Number	A		B		C	D	E	F	G	H	J
	Ret. (mm)	Ext. (mm)	Ret. (mm)	Ext. (mm)							
J58T	30	238	375	584	368	451	71	56	176	41	130
J109T	30	264	419	654	368	451	76	56	183	64	171
J259T	54	289	505	738	210	756	146	102	267	89	270

ORDERING INFORMATION

Cap. Tons	Max Lift Stroke (mm)	Order Number	Strokes to Extend Piston 25,4 mm	Handle Effort at Max Load (kg)	Carry Handle	Metric tons at 700 bar	Product Wt. (kg)
5½	210	J58T	8	38,1	Yes	5,0	19,5
11	235	J109T	13	40	Yes	10,0	29
27½	233	J259T	21	40	Yes	24,9	92,1

Economy TOE JACKS

2, 5 & 10 Ton

Just the power you need at a price you can afford.



ASME B30.1

- These bottle jack-style toe jacks are loaded with many of the same features as our standard bottle jacks, but the toe-lift feature and swiveling pump handle make them ideal for machinery lifting and positioning.
- An internal pressure relief provides added safety by limiting the jack's lifting capability to the capacity of the toe.
- Spring return is an added feature on the larger jacks.
- Swiveling pump handle assembly available on the 5- and 10-ton models. The swiveling jack assembly allows you to access and pump the unit from numerous positions.

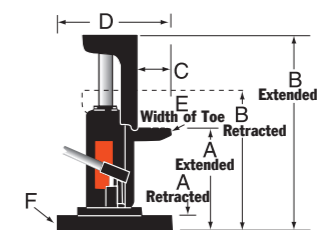

DIMENSIONS

Order Number	A		B		C	D	E	F
	Ret. (mm)	Ext. (mm)	Ret. (mm)	Ext. (mm)				
J24T	16	140	232	356	47,5	181	51	125
J55T	25	149	292	476	47,5	257	76,2	184,2
J106T	32	181	327	476	64	292	100	241

ORDERING INFORMATION

Cap. Tons	Max Lift Stroke (mm)	Order Number	Strokes to Extend Piston at Max Load 25 mm	Handle Effort at Max Load (kg)	Carry Handle	Metric tons at 700 bar	Product Wt. (kg)
2	121	J24T	14	19	Yes	1,8	8,3
5	121	J55T	22	27	Yes	4,5	24
10	146	J106T	31	33	Yes	9,1	38

Bottle Jacks

TELESCOPING

6-15 Ton

These jacks offer greater extended lifting capability.



9006X
Beveled
BASE



ASME B30.1

- Telescoping jacks offer all of the quality features and capabilities of the standard bottle jack line with a bonus. The super-long stroke of these jacks saves time and effort by eliminating the need to lift, crib, lift, etc. In most applications, the user can place the jack once and complete the lift.
- The 9015X offers very low clearance capability, making it the ideal choice for forklift maintenance or machine lifting.
- The taller 9006X, 9011X and 9013X all feature a unique beveled base that allows the jack to "follow" the load laterally as it is raised, greatly reducing side-loading of the piston.

ORDERING INFORMATION

Cap. Stroke Tons (mm)	Order Number	Order Number	Retracted Height Min. (mm)	Length of Screw Ext. (mm)	Height w/Screw Ext. (mm)	No. Pump Strokes to Ext. Piston 25,4 mm	Saddle Dia. (mm)	Base Size Beveled Base (mm)	Pump Handle Length (mm)	Handle Effort at Rated Cap. (kg)	Carry Handle	Metric tons at 700 bar	Product Weight (kg)
6	305	9006X	216	--	521	14	44	121 x 133	700	36	No	5,4	6,4
11	262	9011X	200	68	530	25	41	160 x 165	700	40	No	10,0	8,8
13	254	9013X	230	84	570	35	48	176 x 186	700	36	Yes	11,8	11,3
15	181	9015X	170	70	419	32	52	143 x 194	600	43	Yes	13,6	12

Sidewinder Jacks

MINI JACKS

5-20 Ton

Compact Sidewinder Mini Jack fits in your palm and delivers 5, 10 & 20 tons of lifting force.



9105A



ASME B30.1



- Retracted height of just 63,5 mm for the smallest jack and 130,2 mm for the 20 ton, allows you to slip this jack into the narrowest of crevices.
- Jacks operate either horizontally or vertically. Handles function in line with base for easier use in confined spaces.
- The perfect addition to any toolbox, this remarkable little jack has multiple uses that are limited only by your imagination. Use it as a jack or a spreader. Use it to turn your mechanical gear puller (puller capacity must match jack capacity) into a hydraulic puller. Use it vertically or horizontally in limited clearance.

ORDERING INFORMATION

Cap. Stroke Tons (mm)	Order Number	Order Number	Retracted Height Min. (mm)	Max Height (mm)	No. Pump Strokes to Ext. Piston 25 mm	Saddle Dia. (mm)	Base Size Dia. (mm)	Pump Handle Length (mm)	Handle Effort at Rated Cap. (kg)	Carry Handle	Metric tons at 700 bar	Product Weight (kg)
5	19	9105A	63,5	85,7	30	29	73,8	240	26	No	4,5	1,9
5	38	9205A	88,9	130,2	38	29	73,8	240	26	No	4,5	2,4
10	30	9210A	120,7	149,2	36	42,1	109,9	440	28	No	9,1	5,5
20	30	9220A	130,2	160,3	46	52,8	119,9	605	35	No	18,1	8,0

JACKS

JACKS

Maintenance Sets

Hydraulic system components



IM10E



IM10H

APPLICATION FLEXIBILITY

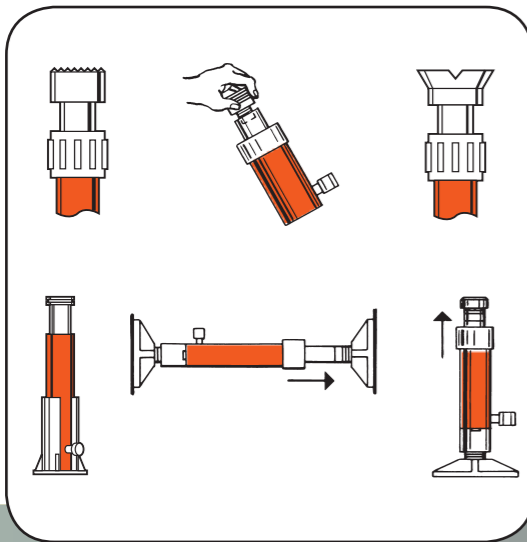

- Matched hydraulic system components, adapters and hydraulic spreader, contained in a rugged carrying and storage case.
- Portable sets are ideal for pushing, pulling, lifting, straightening, or clamping at remote job sites.
- Cylinders in set are rated at 10 tons at 700 bar. Set components are designed for full rated capacity of cylinders.
- Set IM10H includes hand operated pump. Set IM10E includes the Quarter Horse® electrically driven portable power unit.

ORDERING INFORMATION

Description	CONTENTS OF SET	NO. IM10E Order No.	Description	CONTENTS OF SET	NO. IM10H Order No.	NO. IM10L Order No.
Hydraulic spreader		HS2000	Hydraulic spreader		HS2000	HS2000
Hand pump (electric)	PE102	E220 or E110	Hand pump		P59	P59L
700 bar hyd. gauge		9041E	700 bar hyd. gauge		9041E	9041E
Tee adapter		9670	Tee adapter		9670	9670
Hose & coupler assembly		9754E	Hose & coupler assembly		9754E	9754E
90° V base		25395	90° V base		25395	25395
Threaded coupler		25664	Threaded coupler		25664	25664
Serrated saddle		31772	Serrated saddle		31772	31772
Flat base		32325	Flat base		32325	32325
Extension rod - 127mm length		350897	Extension rod - 127mm length		350897	350897
Extension rod - 254 mmlength		38909	Extension rod - 254mm length		38909	38909
Extension rod - 457 mm length		350898	Extension rod - 457mm length		350898	350898
Cyl. support base		420062	Cyl. support base		420062	420062
Cyl. ass'y, 10 ton, 257 mm stroke		C1010CBT	Cyl. ass'y, 10 ton, 156mm stroke		C106CBT	C106CBT
Cyl. ass'y, 10 ton, 156 mm stroke		C106CBT	Storage box		350722	350722
Storage box		350722			Prod. Weight	Prod. Weight
					40,4 kg.	36,8 kg.

Prod. Weight - 48,1 kg.

Post Tension & STRESSING JACKS

20 & 30 Ton

SJ2010 SJ3010



SJ2010DA SJ3010DA

- Power Team Monostrand Stressing Jacks are the most durable in the industry.
- Ideally suited for work on slab-on-grade where dirt, heat and high volume use take their toll.
- Available in single- or double-acting models.
- Standard single-acting units have a 254 mm stroke. Other stroke lengths are available on special order.
- Dead-end seaters for production work and field work available on special order.
- Service repair is simple; components are long lasting and easily replaced.
- 76,2 mm detachable seater nose assembly easily replaced with optional 152,4 mm nose assembly.
- The jack of choice for high-rise and elevated work, thanks to fast return time and light weight.
- All hydraulic fluid controls are interior designed; more efficient and safer operation during tensioning and retraction.
- Standard double-acting units have an 216 mm stroke; others available on special order.
- Specially designed Power Team Control Valves are available for post tensioning jacks. See pages 51.

ORDERING INFORMATION

Description	Cyl. Cap. Tons	Stroke (mm)	Order Number	Recommended Pumps for this Stressing Jack	Oil Capacity (l)	Strand Diameter (mm)	Seater Type	Metric Tons at 700 bar	Weight (kg)
Post tension jack with spring seater, 12,7 mm strand.	20	254	SJ2010	PE554T/PE604T	0,72	11,1-12,7	Spring	20,3	25
Post tension jack with power seater, 12,7 mm strand.	20	254	SJ2010P	PE604PT	0,72	11,1-12,7	Power	20,3	25
Double-acting post tension jack with power seater, 12,7 mm strand.	20	215	SJ2010DA	PE554PT/PE604PT	0,85	11,1-12,7	Power	23,9	19
Post tension jack with spring seater, 15,2 mm strand.	30	254	SJ3010	PE554T/PE604T	1	11,1-15,2	Spring	28,5	34,5
Post tension jack with power seater, 15,2 mm strand.	30	254	SJ3010P	PE604PT	1	11,1-15,2	Power	28,5	34,5
Double-acting post tension jack with power seater, 15,2 mm strand.	30	215	SJ3010DA	PE554PT/PE604PT	1,1	11,1-15,2	Power	36,0	23,5

STRESSING JACK ACCESSORIES AND HOSES—ORDERING INFORMATION

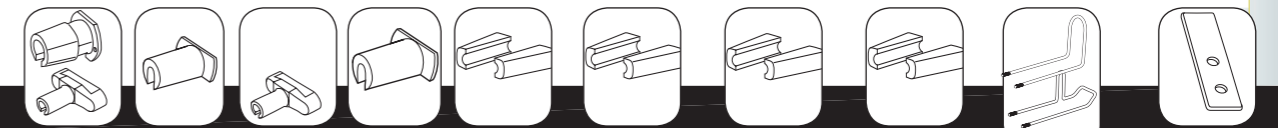

Used with Stressing Jack	76,2 mm Nose Piece	76,2 mm Wedge Seater	152,4 mm Nose Piece	152,4 mm Wedge Seater	9,5 mm Diameter Gripper Set	11,1 mm Diameter Gripper Set	12,7 mm Diameter Gripper Set	15,2 mm Diameter Gripper Set	Replacement Gripper Handle	Gripper Retainer Plate (2 used)
SJ2010	252564	252562	252759	252763	252568	252761	252567	NA	252570	252565
SJ2010P	252564	252562	252759	252763	252568	252761	252567	NA	252570	252565
SJ2010DA	252543	252542	252760	252764	252650	252762	252555	NA	252556	252544
SJ3010	252564	252562	252759	252763	252568	252761	252567	252569	252570	252565
SJ3010P	252564	252562	252759	252763	252568	252761	252567	252569	252570	252565
SJ3010DA	253363	253361	253364	253362	253390	NA	253391	253365	252556	252544

No. 9758E Hose - 3,1 m rubber, wire-braid (2-ply, 2.800 bar burst rating) 3/8" NPTF male hose ends

No. 9763E Hose - 3,1 m rubber, wire-braid (2-ply, 2.800 bar burst rating) 3/8" x 1/4" NPTF male hose ends

TECH DATA

Page 233

Inflatable Jacks

1-74 Ton

JACKS



BE SAFE!
 •INSPECT BEFORE AND AFTER EACH USE.
 •REPLACE IF ANY SIGNS OF DEGRADATION OR WEAR THAT MAY AFFECT SAFETY OR PERFORMANCE.
 •KEEP THE PRODUCT CLEAN.
 •STORE PROPERLY.

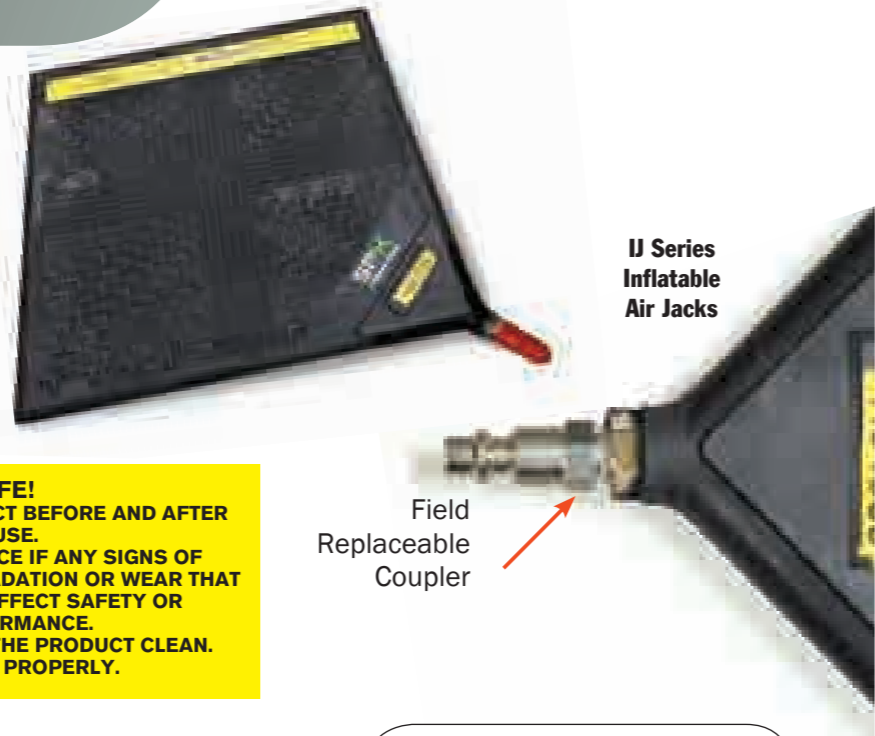

The non-skid space-age reinforced inflatable jack is perfect for many applications.

- Uninflated jacks are less than 25mm thick, making lifting tasks in small spaces seem routine.
- Constructed of non-conducting, high quality rubber material with multi-layer aramid fiber reinforcement.
- Samples of jacks are pressure tested to 20 bar and cycle tested (10,000 inflate/deflate cycles at 8 bar).
- The controller, shut-off and air hoses are all equipped with an industrial interchange style quick disconnect air coupler. Female half coupler bodies have a locking collar to help the operator avoid accidentally disconnecting the jack while under load.
- The top and bottom surface of the jack has a skid resistant, interlocking pattern to assist in alignment of two jacks being used together.
- Single jack controller with “dead man” control (part no. 350090) can be used individually or in multiples to regulate the number of jacks desired.
- Heavy attachment handles are provided on the two largest jacks for attachment of a rope or hook to help in positioning the jack.
- Inflation hose system is color-coded (red and yellow) for easy recognition when using more than one jack.
- The jacks can be used at ambient temperatures of -20°C to + 50°C

Field Replaceable Coupler

IJ Series Inflatable Air Jacks

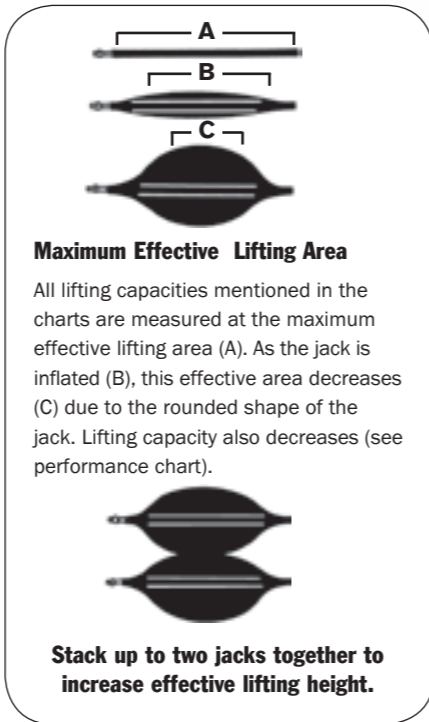

PERFORMANCE

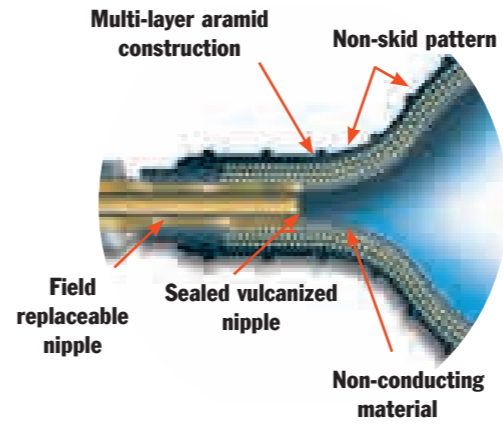
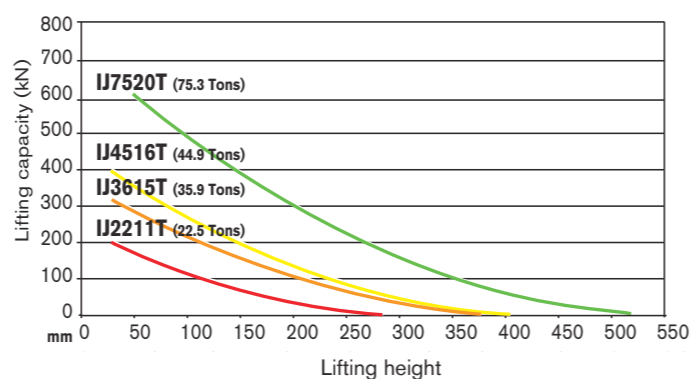
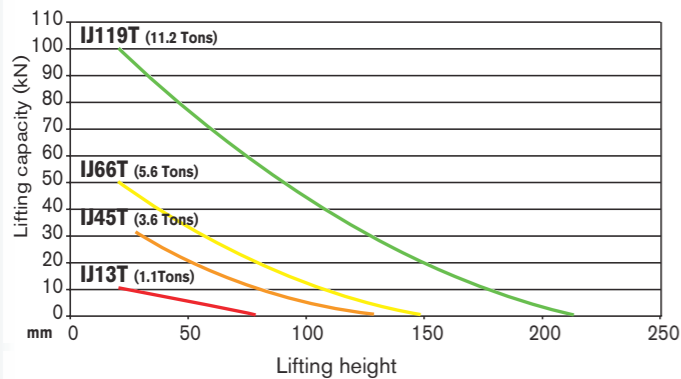

* NOTE: 350090 air controller may be used individually to control one jack (see single line system), or in multiples to control additional jacks (see dual line system).



- No. 307159** – Pressure reducing valve. Allows use of bottled gases to operate jacks (works on CGA-580 Nitrogen/Argon/Helium bottles). Contains standard bottle fitting on inlet and 1/4" industrial interchange (female) outlet. Wt., 1.8 kg
- No. 350090** – Air controller for single jack. Equipped with relief valve and pressure gauge. Wt., 0.9 kg
- No. 350207** – Shut-off hose with shut-off valve and pressure relief valve. Includes a female and male quick coupler. Wt., 0.3kg

- No. 350208** – Air hose. Red, 9m long. Includes No. 250341 female and No. 250342 male quick coupler. Wt., 2.7kg
- No. 350209** – Air hose. Same as 350208, except blue in color. Wt., 2.7kg
- No. 250343** – Female quick coupler. 1/4" industrial interchange x 1/8" NPT female. Wt., 0.05kg
- No. 250353** – Male quick coupler. 1/4" industrial interchange x 1/8" NPT male. Wt., 0.05kg

- No. 250682** – Female quick coupler. 1/4" industrial interchange x 1/4" NPT male. Wt., 0.05kg
- No. 15235** – Connector 1/8" NPT male x 1/4" NPT female. Wt., 0.05kg
- No. 250341** – Female quick coupler. 1/4" industrial x 3/8" I.D. hose. Wt., 0.23kg
- No. 250342** – Male Quick coupler. 3/8" I.D. Hose. Wt., 0.05kg

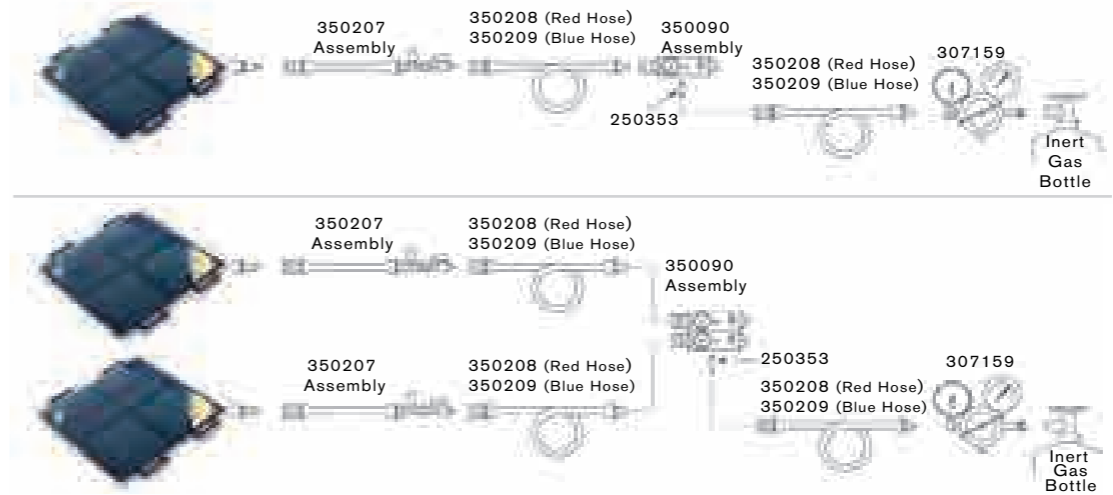

ORDERING INFORMATION*

Lifting Cap. (Metric Tons)	Lifting Height (mm)	Order Number	Air Volume (liter)	Water Volume (liter)	Length (mm)	Width (mm)	Thickness (mm)	Product Weight (kg)
1,0	80	IJ 13T	3.3	0.7	150	150	22	0.6
3,3	130	IJ 45T	16.2	1.8	228	228	22	1.5
5,1	150	IJ 66T	22.5	2.5	270	270	22	2
10,2	215	IJ 119T	76.5	8.5	380	380	25	4
20,4	290	IJ 2211T	189	21	508	508	25	7
32,7	380	IJ 3615T	450	50	658	658	25	13
40,8	405	IJ 4516T	558	62	708	708	25	15
68,4	520	IJ 7520T	1,206	134	908	908	25	24

*See current price list for shipping weights.

JACKS

Portable HIGH TONNAGE JACKS

60-100 Ton Railroad Edition

Portable & compact, ideal for locomotive and railcar maintenance.

JACKS

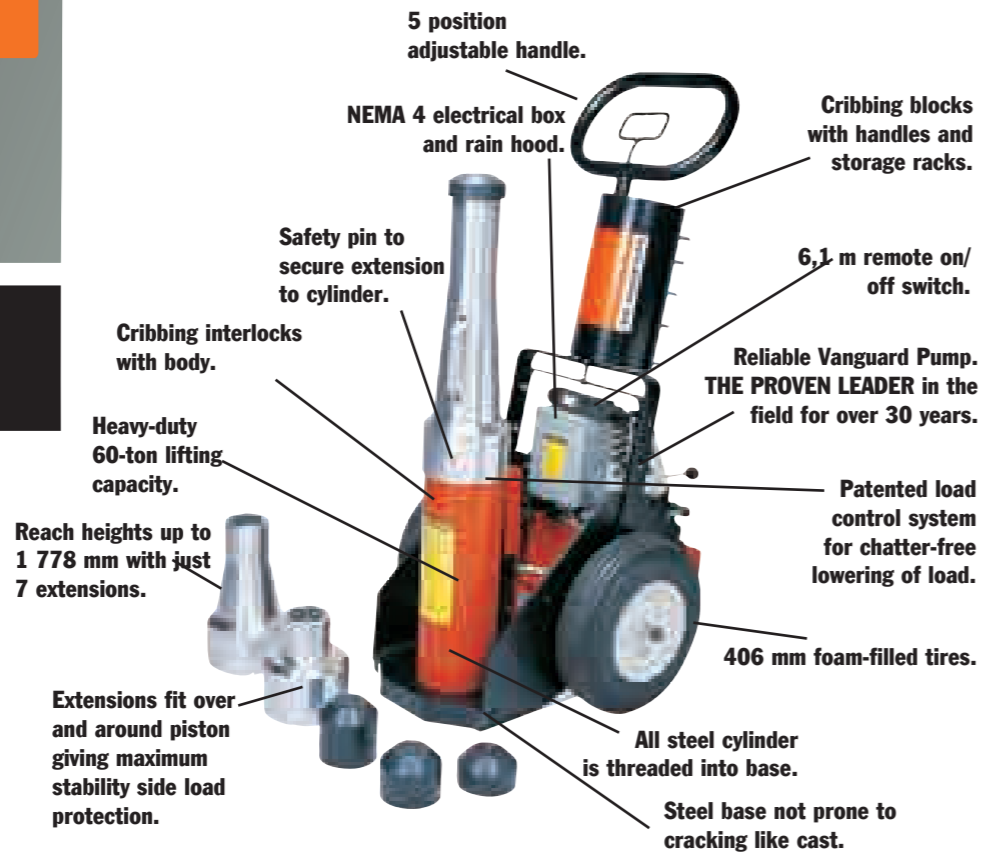

- Patented load lowering valve. Lowers load smoothly and safely. Eliminates dangerous chatter and bounce.
- Full range of rod extensions. Jack comes fully equipped with extensions to match lifting pad heights on most rolling stock. Max. lifting height to 1 778 mm .
- Low collapsed height, long stroke. 610 mm collapsed height for low-clearance lift pads. 360 mm stroke for maximum lift.
- Adjustable, ergonomic handle. Handle tilts to start the job and is easily locked/unlocked without moving from operating position.
- NEMA 4 electrical box and rain hood. Pump motor and controls protected from water. Quiet operation.
- Cribbing block set with handles and convenient storage rack. Provides solid mechanical load holding.
- High-profile, low rolling resistance, foam-filled tires. Jack can be moved and positioned with minimal effort. No chance of downtime due to punctured tires.
- Electric and air motor options. Quiet, powerful air and electric motor powered units available.

POWER UNIT SPECIFICATIONS

Order No.	Motor	Power Req.	Motor Control	Valve Function	Power Cord	dBa at 700 bar
PLE6014-220	0,84 kW, 220 VAC***, 50 Hz Single Phase	12 amps	6,1 m Remote Control	Lift Hold Lower Manual	Pigtail	80/95
PLA6014	Rotary Air Powered	1,4 cu.m at 6 bar	6,1 m Remote Air Control	Lift Hold Lower Manual	NA	82

*** For 110/115V-50/60 Hz order PLE6014



ORDER INFORMATION

Capacity (Tons)	Stroke (mm)	Order Number	Retracted Height (mm)	Extended Ht. w/Extensions (mm)	Product Wt. Less Cribbing & Ext. (kg)
60	356	*PLE6014K	610	1.778	237
60	356	*PLA6014K	610	1.778	237
60	356	*PLE6014K-220	610	1.778	237
100	356	Consult Factory	610	1.499	237

*Includes cribbing block set stored on jack handle rack, and 7 extensions (25,4; 50,8; 76,2; 101,6; 127; 254 and 308 mm)

- PLE6014 = Jack, Electric, includes: Cart, Pump & Cylinder**
- PLE6014-220 = Jack, Electric (220 V.)**
- PLA6014 = Jack, Air, includes: Cart, Pump & Cylinder**
- CBS60 = Cribbing Block Set (5 cribbing blocks)**
- PL60EXT = Extension Set (Consists of 7 extensions)**

CRIBBING BLOCKS (CBS60, INCLUDED)

Qty.	Height (mm)	Order Number
1	38,1	351954
4	76,2	351953

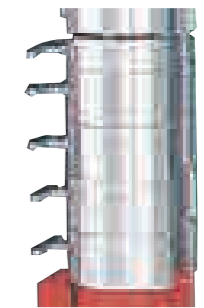

EXTENSIONS (PL60 EXT, INCLUDED)

Extension Length (mm)	Order Number	Extension Weight (kg)
25,4	351931	2,2
50,8	351927	4,0
76,2	351928	6,4
101,6	351929	8,7
127	66053	9,5
254	66054	13,8
508	66055	22,1

LIFTING RANGE

Lifting range (in 25,4 mm increments): 610 mm- 1.778 mm. Only 3 extensions are needed to provide this range. Do NOT exceed 1.778 mm lifting range on 60-ton unit or 1.499 mm on 100-ton unit.

JACKS

Portable HIGH TONNAGE

55, 100 & 150 Ton

Portable and compact, ideal for locomotive/railcar, mining and heavy equipment maintenance.

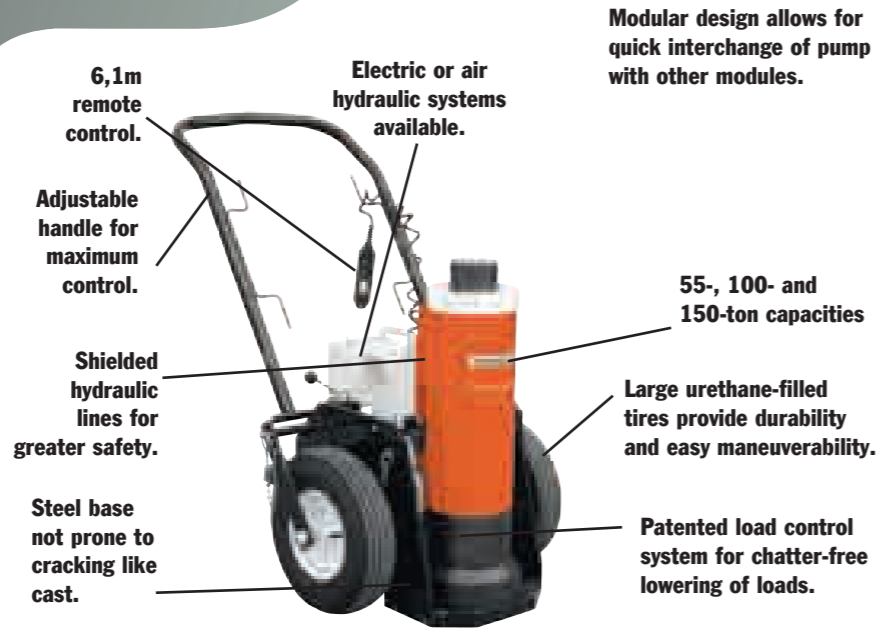

- Modular design - pump and cart separate from cylinder and base.
- Three tonnage capacity options - 55-ton, 100-ton and 150-ton.
- Three collapsed height options - 660, 838 and 1,143 mm.
- Two standard power options - air (PA55) and electric (PE55).
- Two control options - remote motor control and remote valve/motor control.
- Accessory options - 168 mm extension, load-holding rings.
- Select the collapsed height to fit your most frequent application - add jacking modules to suit your needs.
- Remote operation for maximum operator safety and control - choose "motor only" or "motor and valve" control in the hand.
- Easy to maneuver - large tires and small "footprint" make it easy to scoot into the tightest quarters, then locate the exact lifting position.
- Adjustable, heavy-duty handle - makes this jack easy to move, position under vehicles. Can also be used to transport jack on site with a forklift.
- Load-holding rings (optional) - provide full rated mechanical load-holding capability.
- Cylinder extension (optional) - adds more versatility by extending your jack's reach.
- Low-temperature oil (optional) - provides smooth, reliable operation in the coldest climate conditions.
- Modular design - allows you to change lifting modules to suit your tonnage or height requirements. Use the pump module as a portable power station for your other double-acting cylinders (700 bar).
- Exclusive load-control system - provides positive, chatter-free control when lowering the load.
- Shielded and sheltered hydraulic lines - for safer, longer, trouble-free service.

ORDER INFORMATION

CRIBBING BLOCK SETS - INCLUDES ONE JACK MODULE EXTENSION

Order No.‡	55 Ton CBS55		100 Ton CBS100		150 Ton CBS150		200 Ton CBS200		
	No. in Set	1	4	1	4	1	4	1	4
A		38,1	76,2	38,1	76,2	38,1	76,2	38,1	76,2
B		44,5	82,5	44,5	82,5	44,5	82,5	44,5	82,5
C		139,7	139,7	139,7	139,7	222,2	222,2	254	254
Jack Module Ext.		173		177,8		168,3		168,3	
Total Stack Ht.		515,9		520,7		512,2		512,2	
Product Wt. (kg.)		16,3		30,9		38,6		47,7	

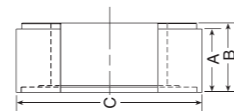

- Convert jack module into stable mechanical cribbing device.
- Increase retracted height up to 521 mm.

ORDER INFORMATION

JACK MODULE EXTENSIONS

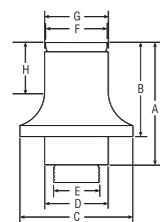

(Tons)	No.	A (mm)	B (mm)	C (mm)	D (mm)	E (in.)	F (mm)	G (mm)	H (mm)	Prod. Wt. (kg)
55	58945	223,8	173	127	66,8	1 ¹¹ / ₁₆ -8UN	63,5	66,8	92,2	9,5
100	58943	228,6	177,8	174,7	98,6	2 ³ / ₄ -12UN	95,3	98,6	95,3	18,2
150	58944	219,2	168,4	203,2	114,3	3 ¹ / ₄ -8UNC	111,3	114,3	88,9	22,7

• Increases jack's reach.



Pump & cart modules

Pump and cart modules contain hydraulic pump, cart, remote control and all hoses and fittings required to connect to a jack module. Contact factory on folding handle cart option.



Remote Control		
Pump	Motor Only	Motor & Valve
Air	PMA55	PMA55S
Electric	Consult Factory	PME55S

Jack modules

Jack modules easily separate from the pump and cart module.

Tonnage	Stroke	Collapsed Height (mm)		
		660,4	838,2	1.143
55	333	JM25	JM35	JM45
100	333	JM210	JM310	JM410
150	460	JM215†	JM315	JM415
200	333	JM220*	JM320	JM420

* collapsed height; 711 mm and stroke 333 mm.
† stroke 333 mm.

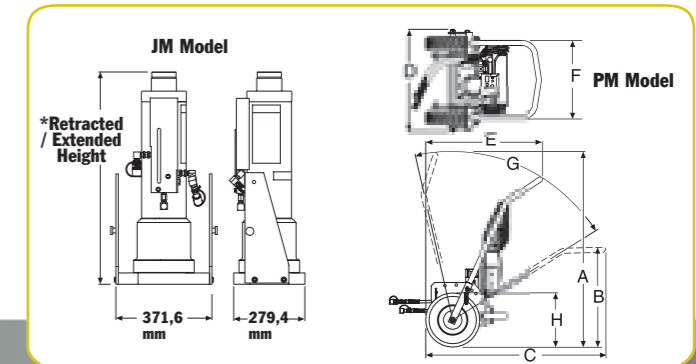

Dimensions

Model Series	A	B	C	D	E	F	G	H
PMA & PME	1.464	752	1.353	762	872	594	*70°	406 mm

* Total range with varying degree increments.

Tire Dia.

ORDER INFORMATION - Pump and Cart Modules with Assembled Jack Module

Capacity (tons)	Ret. Height (mm)	Ext. Height (mm)	Stroke (mm)	Pump Type	Power Required	Valve Type	Remote Control	Order No.
55	660,4	994	333	Electric	13/25 amps	Manual	M	JEM5526
100	838,2	1.172	333	Air	1,4 cu m /min at 6 bar	Manual	M	JAM10033
100	838,2	1.172	333	Air	1,4 cu m /min at 6 bar	Air Pilot	M & V	JAR10033
150	660,4	994	333	Electric	25 amps	Manual	M	JEM15026
150	838,2	1.172	333	Air	1,4 cu m /min at 6 bar	Manual	M	JAM15033

HYDRAULIC & MECHANICAL TOOLS



<p>Page MOTION CONTROL SYSTEM (MCS)...166 Power Team® Synchronized Lifting and Lowering System</p> 	<p>Page NUT SPLITTER...174 15 and 25 Ton</p> 	<p>Page ...182-183 HYDRAULIC PUNCHES</p> 
<p>Page ...168 TWHC SERIES High Cycle</p> 	<p>Page ...175 PIPE FLANGE SPREADER 5 and 10 Ton</p> 	<p>Page TESTERS...184 200, 300 and 750 l/min</p> 
<p>Page TWLC SERIES...169 Low Clearance</p> 	<p>Page ...176 SPREADER 1 and 1 1/2 Ton</p> 	<p>Page ...185-186 SERVICE ACCESSORIES</p> 
<p>Page PE 30TWP...171 Electric Torque Wrench Pump</p> 	<p>Page C CLAMPS...177</p> 	<p>Page ...187 RETAINING RING PLIERS</p> 
<p>Page PE 55TWP...172 Electric Torque Wrench Pump</p> 	<p>Page BEAD BREAKER...178 Tire Removing Tool</p> 	<p>Page ...188 SERVICE TOOLS</p> 
<p>Page RWP55...173 Pneumatic Torque Wrench Pump</p> 	<p>Page FLS...180 Hydraulic Flange Spreader</p> 	<p>Page ...189 WRENCHES & PRY BARS</p> 

Motion Control System (MCS)

Power Team® Synchronized Lifting and Lowering System



MCS-PE554-8 shown.

POWER TEAM® SYNCHRONIZED LIFTING AND LOWERING SYSTEM

The Power Team® Motion Control System provides position control of a load in motion with high precision through a combination of accurate measurements, digital processing and sophisticated hydraulics. The PLC-controlled system is a combination of digital actuation and digital control providing significant advantages such as time savings, repeatability and extremely low internal stress in the moving object. Synchronized lifting reduces the risk of bending, twisting or tilting due to uneven weight distribution or load-shifts between the lift points.



Typical 8-point system

THE SYSTEM CONSISTS OF:

1. PLC controller, pump, and oil reservoir.
2. Displacement sensors to monitor the position of the load.
3. Electrically controlled valves to control the distribution of oil into the hydraulic circuits.
4. Pressure sensors to monitor hydraulic pressures in each hydraulic circuit.

FEATURES:

- Load Capacity: only limited by the choice of cylinders (use with single or double acting cylinders).
- Intuitive graphic, touch screen control.
- Basic systems start at 8 jacking points, also available 16 or 24 points.
- Safety features include: full stop due to power failure, sensor failure, pressure overload, tolerance error, uncontrolled load movement, etc.
- Displayed information includes:
 - Startup diagnostics.
 - Position of lift points relative to starting position.
 - Pressure and load in kN at each lift point.
 - Status of each cylinder.
 - Status of alarms.
- Lifting / lowering accuracy of +/- 1 mm.
- Operating Pressure (up to) 700 bar.
- Standard system has a 151 liter tank.
- Standard system has a PE554 pump unit.
- Suitable for single acting and double acting cylinders.
- Suitable for standard cylinders and telescopic cylinders.

Ordering info: Please contact Power Team for technical support and optimal configuration of your system

Motion Control System (MCS)

Power Team® Synchronized Lifting and Lowering System

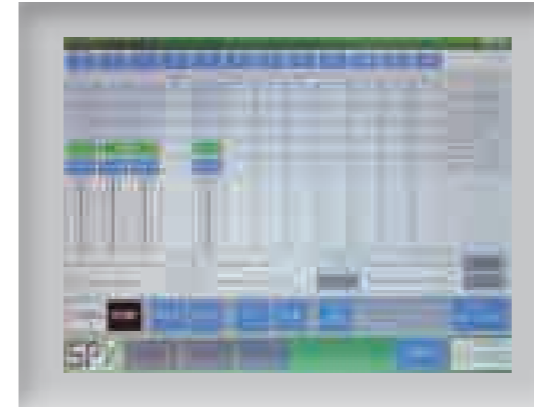

TYPICAL MOVING AND WEIGHING APPLICATIONS:

- Bridges
- Oil rig platforms
- Steel structures
- Vessels and heat exchangers
- Stadium roofs
- Ships
- Heavy vehicles
- Buildings

Torque Wrench

HIGH CYCLE

MAX TORQUE 71816 Nm
700 bar

Heavy duty simple-to-use. Accuracy and speed under load. Breaking nuts loose and torquing.

TWHC HIGH CYCLE TORQUE WRENCH

The TWHC Torque Wrenches are designed with the following:

- Designed for high cycle life: 2 to 3x more than existing technology
- Increased reliability: simple drive assembly means less downtime
- Corrosion resistant material used for use in harsh environments
- Compact nose radius allows the tool to fit in tighter, hard-to-reach spaces
- Low weight, high strength design
- Fast operation, long stroke and optimum flow
- Multi-direction high flow swivel manifold
- Push button square drive reversal and reaction arm positioning
- Push-button release of square drive & reaction arm for all models except TWHC50.
- Fully enclosed drive mechanism for operator safety
- Swivel manifold internal relief valve prevents retract side over pressurization
- Fine tooth pawl prevents tool "lockon"

LOW CLEARANCE TORQUE WRENCHES

The TWLC Wrench was designed for the most inaccessible bolting areas found in industry. Its long neck, short height and small radius have all added to its great success

- Low Weight, High Strength Design
- Superior Torsional Strength
- Fast Operation Cycle
- Fine Tooth Pawl
- Floating Piston Design
- Auto-Connect Drive Piston
- Compact Frame Size
- Rigid Steel Body Construction
- Internal SwivelManifold Relief
- Built-in Reaction Pad
- Small Nose Radius
- Tool Free Link Change
- Corrosion Resistant Finish
- Multi-Axis High Flow Swivel Manifold
- Simple Design
- Consistent Torque Output
- Marathon Lifetime Warranty

Torque Wrench

LOW CLEARANCE

MAX TORQUE 39024 Nm
700 bar

The lightweight, heavy-duty tool features a long neck, short height, and small radius for inaccessible bolting areas found in industry.



Air Pump TORQUE WRENCH PUMP

Air/Hydraulic
700 bar

Faster, quieter and lighter than typical 2-stage portable pumps – the Air/Hydraulic Pump is a constant horsepower pump that provides consistently high hydraulic flow and pressure for faster tool operation. A typical two stage pump flow curve transitions high to low flow around 48 bar. The Air Pump has much higher, smoother flow throughout the pressure curve and the hydraulic flow continually changes based on pressure - making maximum horsepower and flow at all pressures. The largest flow increase is between 69 & 414 bar, where torque wrenches normally operate - dramatically increasing productivity. As a result, tools operate up to twice as fast vs. two-stage pumps, getting tasks done in much less time.

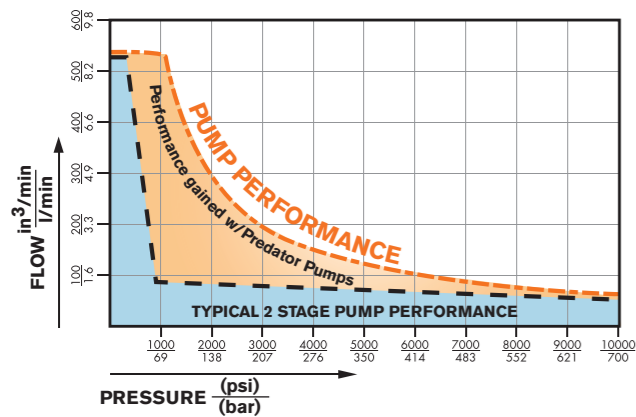

Constantly variable flow also allows continuous operation and eliminates the need for external heat exchangers and cool-off downtime.

The Air pump is designed to be rugged, but light weight for ease of transporting it to a job site. It is engineered for low sound levels to reduce operator fatigue and increase productivity. A roll cage option allows users to customize the Air Pump to suit their needs.

The Pump also comes in an electric/hydraulic model. For a complete high force hydraulic package, Power Team offers a full range of cylinders, tools, and torque wrenches to match the pump hydraulic power source.



Technical Data

REQUIRED AIR PRESSURE

2,3 m³/min à 5,5 bar
2,5 m³/min à 6 bar
2,8 m³/min à 7 bar

MAXIMUM HYDRAULIC PRESSURE OUTPUT

700 bar

SOUND LEVEL

75 dB A

HYDRAULIC OIL RESERVOIR CAPACITY

5,68 l useable min. on base tank

HYDRAULIC OIL DELIVERY

	7 bar	6 bar	5,5 bar
50 bar	9,4 l/min	9,3 l/min	8,9 l/min
172 bar	3,8 l/min	3,7 l/min	3,4 l/min
345 bar	1,9 l/min	1,8 l/min	1,7 l/min
700 bar	0,9 l/min	0,9 l/min	0,8 l/min

* Values shown are with filter/regulator/lubricator, values will increase without FRL

SIZE

HEIGHT = 51 cm | WIDTH = 46 cm | LENGTH = 30 cm

WEIGHT

36 kg with 4,7 L hydraulic oil

Features & Benefits

- Quiet operation
- Light weight for easy portability
- Cool operation without add-on heat exchanger
- Rugged construction for durability in tough environments
- Fewer parts for lower service costs
- CE
- ATEX II 2 GDc T4

Part Numbers

PA60APF5FP – standard with handle and guard

PA60APF5FPR – with roll cage

VANGUARD® ELECTRIC HYDRAULIC TORQUE WRENCH PUMPS

- Two-speed general duty pump
- External adjustable pressure regulator
- Retract side internal relief valve protects tool
- Hand remote
- Use for double or single acting tools



CAUTION: This system should not be used for lifting applications.

Electric Pump HYDRAULIC TORQUE WRENCH PUMP

PE30 Series
5 l/min Max Flow
700 bar

HYDRAULIC TOOLS

Pump Model	Oil Delivery	Oil Reservoir (l)	Usable Oil (l)	Overall Width (mm)	Overall Length (mm)	Overall Height (mm)	Pump Weight w/Oil (kg)
PE30TWP-E110*	5 l/min. at 7 bar	4,75	4,5	356	331	458	30,9
PE30TWP-E220*	0,5 l/min. at 700 bar	4,75	4,5	356	331	458	33

	Electric Motor	Electrical Data	Electrical Control
PE30TWP	4,000 rpm		24 Volt remote control with 3 m cord
PE30TWP-E110*	0,75 KW, 115V/50Hz, 13 A		
PE30TWP-E220*	0,75 KW/220V/50Hz, 7 A		

*CE Approved - designed for 50 Hz applications



Electric Pump
HYDRAULIC TORQUE WRENCH PUMP

PE55 Series
11,5 l/min MAX FLOW
700 bar



- VANGUARD® ELECTRIC HYDRAULIC TORQUE WRENCH PUMPS**
- Two-speed high performance pump
 - External adjustable pressure regulator
 - Retract side internal relief valve protects tool
 - Hand remote
 - Use for double or single acting tools
 - Four-tool manifold (-4 model only) allows use of up to four tools simultaneously

CAUTION: This system should not be used for lifting applications.

HYDRAULIC TOOLS

Pump Model	Oil Delivery (l/min)	Oil Reservoir (l)	Usable Oil (l)	Overall Width (mm)	Overall Length (mm)	Overall Height (mm)	Pump Weight w/Oil (kg)
PE55TWP							
PE55TWP-E110*	11,5 at 7 bar	9,5	8,4	435	241	460	34
PE55TWP-E220*	0,9 at 700 bar						
PE55TWP4							
PE55TWP4-E110*	11,5 at 7 bar	9,5	8,4	470	241	486	35,4
PE55TWP4-E220*	0,9 at 700 bar						

	Electrical Data	
	Electric Motor	Electrical Control
PE55TWP	0,84 KW, 12000 rpm	Remote control with 3m cord
PE55TWP-E110*	115V, 25 amps	
PE55TWP-E220*	110V/50Hz, 25 amps 220V/50Hz, 13 amps	

* CE Approved-designed for 50Hz. applications.

AIR HYDRAULIC TORQUE WRENCH PUMP

- Use where air is the preferred source of power
- Powerful 2,2 Kw motor starts under load
- External adjustable pressure regulator
- Retract side internal relief valve protects tool
- Use for double or single acting tools
- Usable in hazardous areas: per ATEX II, 2 GDc T5



CAUTION: This system should not be used for lifting applications.

HYDRAULIC TOOLS

Pump Model	Oil Delivery (l/min)	Oil Reservoir (l)	Usable Oil (l)	Overall Width (mm)	Overall Length (mm)	Overall Height (mm)	Pump Weight w/Oil (kg)
RWP55	7,6 l/min at 7 bar 0,9 l/min at 700 bar	9,5	8,4	450	280	483	44
RWP55-4 (4-tool manifold)	7,6 l/min at 7 bar 0,9 l/min at 700 bar	9,5	8,4	450	280	483	44

Motor Data		Air Control
Air Motor		
2,25 KW		Pneumatic remote control with 3,6 m cord
1,4 m³ / min @ 6 bar		



Nut Splitters

HYDRAULIC

15 & 25 Ton Capacity

HYDRAULIC NUT SPLITTERS – 15- & 25-TON CAPACITY

- “Dial-in” feature on HNS150 makes adjustment of splitter simple, without the worry of damaging the bolt
- Specially designed “tool steel” cutter blade penetrates the nut to the precise point where it cracks, stopping short of the bolt threads
- Nut splitter features a dramatically improved cutter blade with an 800% greater resistance to chipping and breaking over previous models

- All models feature a rugged one-piece cutting frame coupled to a heavy-duty hydraulic cylinder
- Compact size allows you to use it in confined areas where it will deliver enough force to split the toughest “fused” or rusted-on grade 2H nuts
- Simply split nut on one side, spin nut splitter 1/2 turn and make second cut on opposite side; nut separates into halves for easy removal

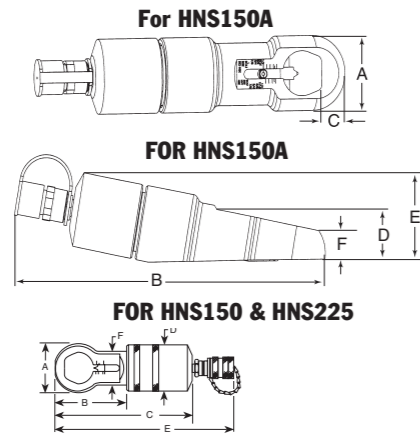

Align mark on cutter blade with scale.



Pipe Flange

HYDRAULIC SPREADERS

5 & 10 Ton

- You'll never again have to resort to “hammer and chisel” methods that waste time and effort. Flange spreaders should be used in pairs to provide even spreading force.
- Standard 60° wedge is suitable for most flanges; 30° “thin” and 60° “blunt” wedges are optional.
- The HFS3A is designed for applications where total thickness of flanges and max. spread gap is 76,2 mm or less and flange bolts are a min. of 17,5 mm dia.
- Use HFS6A if total thickness of flanges and max. spread gap is 152,4 mm or less, and flange bolts are a min. of 20,7 mm dia.

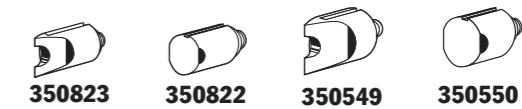

Tool Model	FOR HNS150 & HNS225						HEAD THICKNESS (mm)	REPLACEMENT BLADE	TOOL WEIGHT (kg)
	A	B	C	D	E	F			
HNS150	73	86	200	70	264	53	25,4	308840	3,7
HNS150A	77	361	27	54	94	30	25,4	351985	7,2
HNS225	108	153	366	99	C	82	38,1	308022	13,2

Tool Model	CAPACITIES			
	5 (2 or A)	Nut Grade 9 (5 or B)	10 (8 or C)	12 (2 or H)
HNS150	1/2 - 1-1/2" (12,7-38,1mm) hex	1/2 - 1-1/2" (12,7-38,1mm) hex	1/2 - 1-5/16" (12,7-33mm) hex	1/2 - 1-1/8" (12,7-29mm) hex
HNS150A	1/2 - 1-1/2" (12,7-36mm) hex	1/2 - 1-1/2" (12,7-36mm) hex	1/2 - 1-5/16" (12,7-33mm) hex	1/2 - 1-1/8" (12,7-29mm) hex
HNS225	1-1/8 - 2-1/4" (29-57mm) hex	1-1/8 - 2-1/4" (54-57mm) hex	1-1/8 - 2-1/8" (29-55 mm) hex	1-1/8 - 1-11/16" (29-43mm) hex

Capacity (tons)	Order Number	Standard Wedge Type	Optional Wedges		Min. Flange Opening (mm)			Max. Flange Opening (mm)			Combined Flange Opening (mm)	Max. Pin Dia. (mm)	Weight (kg)
			30° Thin	60° Blunt	60° Std.	60° Blunt	60° Std.	60° Blunt	30°				
5	HFS3A	60° Sharp	350823	350822	1,6	25,4	1,6	38,1	38,1	18,3	76,2	17,4	4,1
10	HFS6A	60° Sharp	350549	350550	1,6	38,1	1,6	50,8	50,8	24,6	152,4	20,6	8,2

TECH DATA

Page 231

Spreaders HYDRAULIC

1-1½ Ton

It's a hydraulic pry bar!

HS3000
(High Grade Ductile Iron)



Tested to conform to ASME B30.1 standard

- Use to lift machines or as a clamp; spread concrete forms or rebar or perform straightening jobs.
 - Conforms to ASME B30.1 standard.
 - High strength alloy steel forged upper and lower jaws on HS2000.
 - Jaws are spring-return; retract automatically when pressure is released.
- No. HS2000** - 1-ton capacity spreader. Full 908 kg capacity at 700 bar with 102mm spread. Can be "dead-ended" at 102mm spread under full load. Needs only 14,2mm clearance to engage jaws.
- No. HS3000** - 1½-ton capacity spreader. Full 1.362 kg capacity at 700 bar with 292 mm spread. Greater than competitive units. Needs only 30,2 mm clearance to engage jaws. Can be "dead-ended" at 292 mm spread at full load.

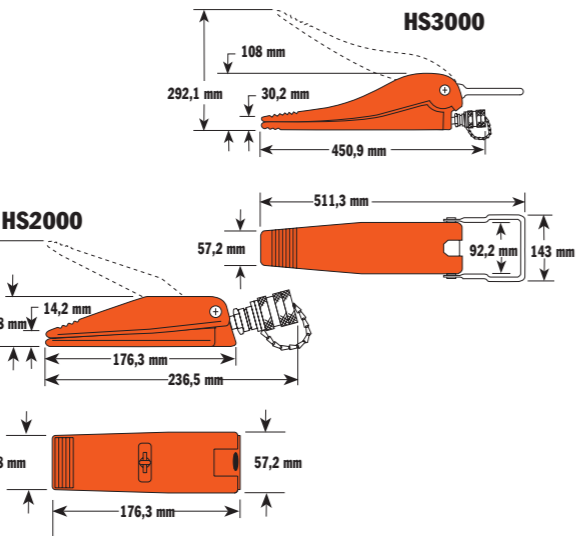

Capacity (tons)	Max. Spread (mm)	Order Number	A (mm)	B (mm)	C (mm)	D (mm)	E (mm)	F (mm)	G (mm)	H (mm)	I (mm)	Oil Capacity (cm³)	Min. Clearance Required (mm)	Weight (kg)
1	101,6	HS2000	101,6	50,4	14,3	252,52	236,5	50,8	176	57	-	4	14,2	2,2
1½	292	HS3000	292	108	30,2	-	451	57,2	511	143	92	20	30,2	10

HS2000 SPECIFICATIONS				HS3000 SPECIFICATIONS			
Maximum rated capacity1 ton at 700 bar	Maximum rated capacity 1½-ton at 700 bar				
Maximum spread 101,6 mm	Maximum spread 292 mm				
Minimum clearance required 14,2 mm	Minimum clearance required 30,2 mm				
Cm³ oil required 4	Cm³ oil required 20				



"C" CLAMPS

5, 10 & 25 TONS



- In 5, 10 and 25 ton capacities. For use with Power Team general purpose single-acting series cylinders of comparable capacity.
- For clamping, pressing and bending. Ideal for welding and metal fabrication for fit-up of sheet or plate steel.
- Clamps withstand full rated capacity of the cylinders for which they are intended.
- To minimize the effects of off-center loading, the CC5, CC10 and CC25 should be used with the optional 350144 and 350145 swivel caps.

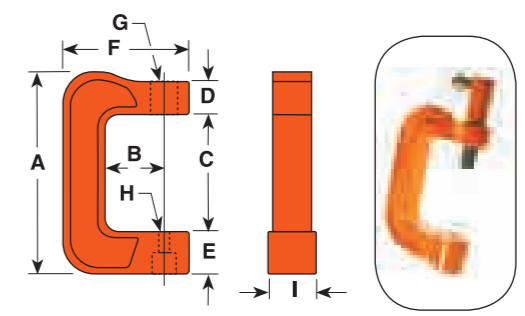

Items pictured at left are:
CC10
C104C
201923

Cap. (tons)	Order Number (C-Clamp only)	Use With Cyl. No.	A (mm)	B (mm)	C (mm)	D (mm)	E (mm)	F (mm)	G (in.)	H (mm)	I (mm)	Weight (kg)
5	CC5	C51C-C57C	314	95,3	186	50,8	63,5	197	1½"-16 UN	22,2	76,2	11,3
10	CC10	C101C-C1010C	403	152,4	240	50,8	85,8	273	2 ¼"-14 UNS	22,2	88,9	20,9
25	CC25	C251C-C2514C	533	152,4	319	76,2	114,3	313	3 ⅝"-12 UNS	36,5	117,5	41,3

OPTIONAL ACCESSORIES FOR USE WITH CC5, CC10 & CC25 HYDRAULIC CLAMPS

Swivel Caps		Threaded Adapters		Pushing Adapters			
10 ton 350144*	25 ton 350145	10 ton 38597	25 ton 38953	10 ton 28228**	25 ton 28229**		
A-35 mm B-19 mm	A-50,8 mm B-25,4 mm	A-1 - 8 B-1 - 8 C-19 mm D-50,8 mm	A-1½-7 B-1½-16 C-70 mm D-111 mm	A-60,3 mm B-1 - 8 C-38,1 mm	A-73 mm B-1½-7 C-44,5 mm		
Pushing Adapters		Pushing Adapters		V Pushing Adapters		Pushing Adapters	
10 ton 201923**	25 ton 34510**	10 ton 201454**	25 ton 34511**	10 ton 34806**	25 ton 34807**	5 ton 309874*	
A-79,4 mm B-57,2 mm C-136,5 mm D-12,7 mm E-1 - 8	A-82,6 mm B-66,7 mm C-149 mm D-19 mm E-1½-7	A-79,4 mm B-57,2 mm C-137 mm D-19 mm E-1 - 8	A-82,6 mm B-66,7 mm C-149 mm D-25,4 mm E-1½-7	A-66,7 mm B-1 - 8 C-38,1 mm D-25,4 mm	A-79,4 mm B-1½-7 C-44,5 mm D-31,8 mm	A-51,6 mm B-562,8 mm C-15,9 mm	

* May be used with CC5
** Must be used with a threaded adapter.

HYDRAULIC TOOLS

HYDRAULIC TOOLS

Tire Removing

BB SERIES TOOL

10 Ton Hydraulic

Unseat tire beads hydraulically on 25" to 49" diameter earth mover rims with pry bar pockets.

HYDRAULIC TOOLS

TIRE REMOVING TOOL

- Made to fit into the pry bar pocket
- Hydraulic pressure does all the unseating.
- Lightweight and portable.
- P55 hydraulic hand pump and 9764 hose recommended to be used with BB1600.



Tool Model	Tool Weight kg.	Rim Size	Cylinder Capacity	Stroke (mm)
BB-1600	10,25	25"-49"	10	101,6
BB1601	10,9	25"-49" Single, two, three piece rims	10	101,6
Contact Factory	13,65	25"-51"	12,3	107,9

POWER TEAM GIVES MUSEUM PROJECT A LIFT

CHALLENGE:

To lower the basement floor by 1.4 meters, removing the basement walls to open up space for the new facilities and street-level entrance and with control and maximum flexibility for a very restricted budget.

SOLUTION:

Using several Power Team hand pumps and sets of cylinders that would be spread out along each beam. Cylinders were selected that could fit in the very tight gaps available to accommodate the lifting equipment



FLS
HYDRAULIC FLANGE SPREADER



Basic FLS15 Unit With Serrated Shoes

HYDRAULIC SPREADER FLS15

This hydraulic spreader operates using the integrated wedge concept. It is ideal for creating space for flange surface cleaning and repair, and for gasket replacement. The spreader is single-acting, and requires a hydraulic pump with a three-way valve for actuation. Maximum operating pressure is 700 bar.



FLS
HYDRAULIC FLANGE SPREADER

FEATURES AND BENEFITS:

- 15 Metric Ton Wedge-Driven Spreader
- Jaws Fully Supported by Wedge for Excellent Durability
- Low Friction Provided by Heavy-Duty Extended-Life Lubricant
- Ideal for Flanges With Narrow Gaps - Only 5 mm Required for Entry
- Very High Strength due to Special Alloy Used
- Compact and Lightweight Design - Only 252 mm Long at a Weight of 3.2 kg
- Easy to use - Ergonomically Balanced Handle and Gripping Tape
- Suitable for the Offshore Environment due to Superior Corrosion Resistance
- Quick Adjustments for Various Tasks due to Interchangeable Shoes (Both Stepped and Serrated)
- Easy and Quick Maintenance - No Special Tools Required
- Includes female half coupler - mates to standard 9798 male half coupler.

Max. Spreading Force	Order no.	Tip Clearance	Max. Spread	Type	Oil Capacity	Weight	Operating Pressure
15 ton	FLS15 FLS15-ST	5 mm	10 mm pro Hub	Hydraulic	16 cm ³	3,2 kg	max. 700 bar

Wedge opened	Wedge closed	Wedge opened	Wedge closed
FLS15	FLS15	FLS15-ST	FLS15-ST



OFFSHORE FLANGE SPREADER KIT*		part number FLS15-FSK	part number FLS15-FSK-ST	part number FLS15-MSK	part number FLS15-MSK-ST
FLS15	SPREADER, HYDRAULIC SERRATED	2	-	1	-
FLS15-ST	SPREADER, HYDRAULIC STEPPED	-	2	-	1
SB15	ALUMINIUM HOLDING BLOCK	2	2	1	1
P19L	LIGHTWEIGHT HAND PUMP WITH GAUGE	1	1	-	-
3000827	MANIFOLD, 2 NEEDLE VALVE ASSEMBLY (incl. 2 gauges)	2	2	-	-
9765E (1x) and 9767E (2x)	HOSES	3	3	-	-
2008577	HEAVY DUTY CASE	1	1	-	-
3000832	HEAVY DUTY CASE	-	-	1	1

TOPSIDE FLANGE SPREADER KIT**		part number FLS15-FBK	part number FLS15-MBK	part number FLS15-FBK-ST	part number FLS15-MBK-ST
FLS15	SPREADER, HYDRAULIC SERRATED	2	1	-	-
FLS15-ST	SPREADER, HYDRAULIC STEPPED	-	-	2	1
SB15	ALUMINIUM HOLDING BLOCK	2	3	2	3
P19L	LIGHTWEIGHT HAND PUMP WITH GAUGE	1	1	1	1
MANIFOLD	MANIFOLD, 2 NEEDLE VALVE ASSEMBLY (incl. 2 gauges)	1	-	1	-
9765E (1x) or 9767E (2x)	HOSES	-	1	3	1
2008410	HANDLE FOR SPREADER	2	1	2	1
2008650	STANDARD CASE	1	1	1	1

SPREADING FORCE:

Maximum 15 metric tons per tool at 700 bar. It is recommended that the tools be used in pairs, providing a maximum combined force of 30 metric tons.

TYPICAL APPLICATIONS:

- Pipe and flange repair
- Removing elbows
- Couplers - gasket and metal seal Replacement
- Heavy equipment maintenance

"RECOMMENDED COMPONENTS FOR A COMPLETE HYDRAULIC CIRCUIT"



Optional handle
Part Number 2008410



Optional Stepped Shoe
Part Number 2008083*



Optional Stepped Block
Part Number SB15 (1 pc)

Note: Part number is for one shoe only. Two shoes required per spreader. Two stepped shoes shown.

WE RECOMMEND USE OF THE FOLLOWING POWER TEAM COMPONENTS:



Pump



Coupler



Hose



Gauge



Gauge Adapter

Description	Part Number
Two Speed, Single-Acting Hand Pump	P19L
Hydraulic Hose Assembly	9764E
Pressure Gauge	9040E
Gauge Adapter	9670
Coupler (male half coupler)	9798

Note: Torque wrench tools use smaller couplers. Do not attempt to use torque wrench hoses with this tool.

Hydraulic PUNCHES

20 & 35 Ton

- Punch smooth, precise holes in seconds; much faster than drilling.
- Fully portable for construction, maintenance and service applications, or can be mounted on a workbench for production jobs. Has carrying handle for precise locating.
- Rugged, forged steel "C" frame for great strength and durability.
- Dual action, spring loaded stripper holds material during punching operation, strips material from punch on return. Scribe lines on stripper aid in locating the punch (HP 35 only).
- Double Acting prevents binding and speeds retraction (HP20 only).
- The PE172 electric/hydraulic pump is an ideal power source.



No. HP35 – Punch only, includes metal case and die change tools. Wt., 19 kg.
No. HP35S – Punch with punches and dies. Includes HP35 punch, metal case and 250459 punch/die set. Wt., 20 kg.
No. HP35P – Punch set with pump. Same as HP35SP, but does not include punch/die set. Wt., 39 kg. NOTE: Available in 220 volt, 50 Hz. Order with suffix "-220".

No. HP35SP – Punch set with pump. Includes HP35 punch, PE172 electric/hydraulic pump, 9756 hose, 9798 hose half coupler, 250459 punch/die set, metal case. Wt., 40 kg. NOTE: 220 volt, 50 Hz. Order with suffix "-220".
No. 250459 – Punch/die set for round holes. Includes one each: PD437 11,1 mm punch/die, PD562 14,3 mm punch/die, PD688 17,5 mm punch/die, PD812 20,6 mm punch/die. Wt., 0,7 kg.

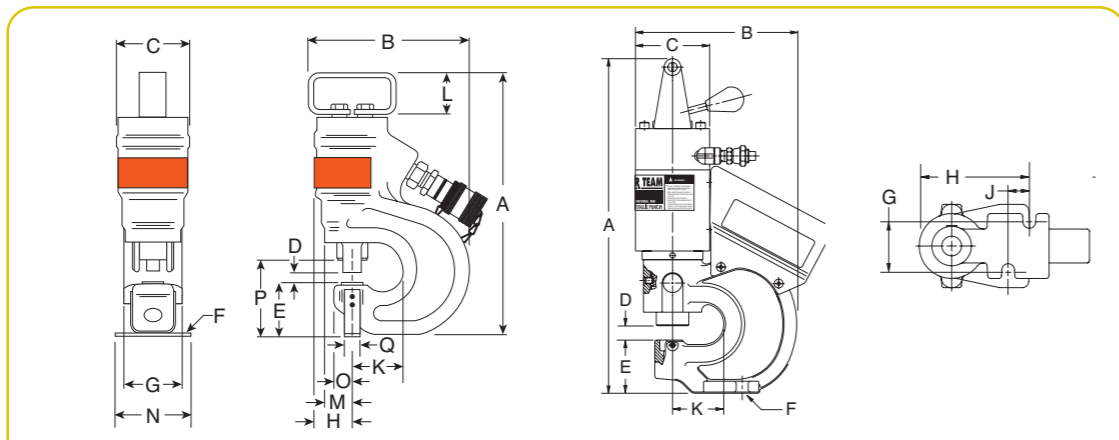

Order Cap.	Order Number	Max. Oper. Press. (bar)	Max. Oil Cap. (cm ³)	Max. Material thickness (mm)	Max. Throat Depth																
					A (mm)	B (mm)	C (mm)	D (mm)	E (mm)	Mtng. Holes (mm)		F (mm)	G (mm)	H (mm)	J (mm)	K (mm)	L (mm)	M (mm)	N (mm)	O (mm)	P (mm)
20	HP20	700	64	12,7	419	202	93	16	66	14	54	124	24	57	—	—	—	—	—	—	—
35	HP35	700	75	12,7	349	229	95	14	73	6	76	46	—	71	57	38	89	22	102	19	—



No. HP20 – Basic punch. Wt., 15 kg.
No. HP20S – Punch frame with cylinder, valve, handle, two coupling nuts, plus five punch and die sets in 6,4 7,9 ,9,5 ,11,1 and 13,5mm dia. Wt. 15,9 kg .
No. HP20SP* – Complete punch set with PE102AR pump (115/230V, 50/60 Hz), HP20HS hand switch, 9682 nipple, two 9792 female couplers and two 9793 male couplers. Also includes two 9758 3 m hoses, 9680 coupling, and same punch and die sets as in HP20S (above). Tool is completely assembled and pre-filled with oil. In storage box. Wt., 15,9 kg.

HP20

Punch Set HP20SP
 Includes the PE102AR pump, HP20HS hand switch, hoses, couplers, punch and die sets in sizes 6,4, 7,9 ,9,5 ,11,1 , and 13,5 mm diameter, with storage box Wt.15,9 kg.

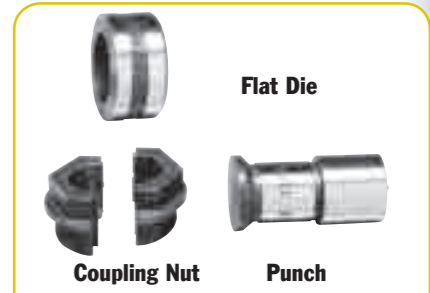

TYPICAL 20 TON STYLE TOOLING

PUNCH/DIE SETS FOR HP20 & HP35 HYDRAULIC PUNCHES										Punch Size (mm)	INCHES		MM	
For use with HP20 Hydraulic Punch					For use with HP35 Hyd. Punch						Hole Dia.	Bolt	Hole Dia.	Bolt
Punch Size (mm)	Punch Style	Punch No.	Flat Die	Bevel Die No.	Coupling Nut No.	Punch/w Flat Die Set	Punch/w Bevel Die Set							
6,4	Round	251970		--	252001	--	--	6,4	1/4	#10	6,3	—		
7,9		251971	251983	--	252001	PD313	--	8,0	5/16	1/4	7,9	—		
9,5		251972	251984	251996	252001	PD375	PD375B	9,5	3/8	5/16	9,5	M8		
11,1		251973	251985	251997	252001	PD437	PD437B	11,1	7/16	3/8	11,2	M10		
13,5		251974	251986	251998	252001	PD531	PD531B	13,5	17/32	7/16	13,5	M12		
14,3		251975	251987	251999	252001	PD562	PD562B	14,3	9/16	1/2	14,3	—		
17,5		251976	251988	--	252001	PD688	--	17,5	11/16	5/8	17,5	M16		
19,8		251977	251989	--	252002	PD781	--	19,8	25/32	—	19,8	M18		
20,6		251978	251990	--	252002	PD812	--	20,6	13/16	3/4	20,6	—		
12,7		Square	251979	251991	--	252002	--	--						
13,5	Obround	251980	251992	--	252002	--	--							
6,4 x 19		251981	251993	--	252002	--	--							
9,5 x 19		251982	251994	--	252002	--	--							
		251995												



ACCESSORIES FOR HP20 HYDRAULIC PUNCH

No. HP20FS – Optional foot switch mounted in foot switch guard. Supplied with 3 m cord and male remote connector. Wt., 0,9 kg.
No. HP20HS – Replacement handswitch. Supplied with 3 m cord and male remote connector. Wt., 0,9 kg.
No. 252000 – Optional coupling nut wrench. Makes punch/die changes easier without "rounding-off" coupling nuts. Wt., 0,3 kg.

TECH DATA

Testers HYDRAULIC

200, 300
and 750 l/min



HT50A



HT200

200 , 300 AND 750 L/MIN IN-LINE HYDRAULIC TESTERS

- Accurately measure oil flow, pressure and temperature on in-plant equipment, forklifts, machine tools and more.
- Temperature and flow readings are in Metric and English, accurate to within $\pm 2\%$ of full scale.
- Dual pressure gauges for high and low pressure readings; low pressure gauge is automatically shut off and protected as pressure rises beyond its maximum reading.
- Automatic pressure compensating feature lets you increase flow without

affecting pressure setting.

- Reverse flow through tester will not cause damage; replaceable safety disc ruptures if pressure exceeds upper limit.
- Solid state voltage regulator eliminates errors caused by voltage change during testing.
- Troubleshoots systems with capacities to 750 l/min at pressures less than 350 bar. Accurately measure oil flow to $\pm 5\%$, pressure to within 2% and temperature readings within 1%.
- Pressure gauge is liquid filled to dampen system pulsation.

For more precise low pressure readings, an optional dual pressure gauge kit is available (see page 183).

No. HT50A – Hydraulic circuit tester with single liquid filled pressure gauge, 0-5000 psi, 0-350 bar. Includes two adapter unions for 3/4" male NPTF fittings. Wt., 16,8 kg.

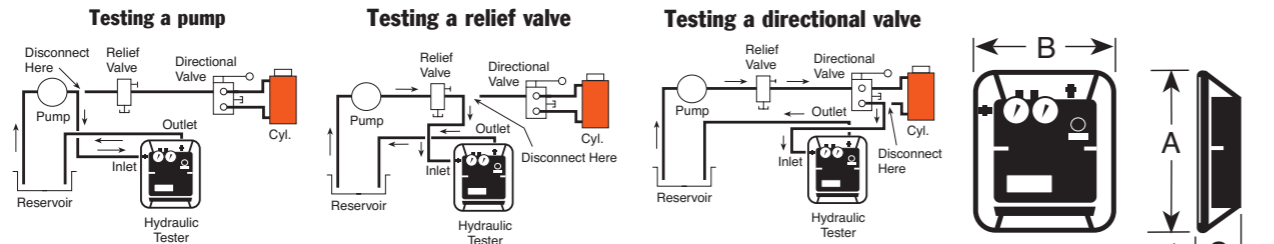

Order Number	Max Flow (l/min)	Flow Ranges (gpm) (l/min)	Max. Oper. Pressure		Temp. Scale Range		Port Sizes	Weight		A in. (mm)	B in. (mm)	C in. (mm)		
			psi	(bar)	°F	°C		lbs.	kg.					
HT50A	200	—	0-50	0-200	5,000	345	20-240	-6 to 114	1 1/16-12UN Female "O" Ring with Union Adapt. 3/4" Female NPTF	30.3	16.8	12 1/4 (311)	6 1/4 (159)	10 (255)
HT75	300	High Low	15-75 3-15	50-300 10-60	5,000	345	100-250	40-120	3/4" NPT Swivel	18.2	8.6	13 3/4 (349.25)	11 7/8 (301.62)	5 3/4 (146.05)
HT200	750	High Low	25-200 5-40	100-750 20-150	5,000	345	100-250	40-120	1 1/2"* SAE Split Flange	28.2	13.6	15 7/8 (403.47)	13 1/4 (336.55)	6 3/4 (171.45)

For a complete listing of accessories for the HT series of hydraulic system testers, see pages 193-194.
*Not included, must be ordered separately, see page 194.

Service Accessories HYDRAULIC TESTER

DUAL GAUGE CONVERSION KIT FOR 50 GPM TESTER.

Provides more precise low pressure readings. Remove pressure gauge block and gauge from tester and replace it with this block. Install high pressure gauge from tester (350 bar) onto this new block.

No. 307281 – Dual gauge conversion kit. Consists of gauge mounting block, pulsation dampener, thermal overload protector, low pressure gauge and gauge protector. Wt. 0,45 kg.



307281

307281 Low pressure gauge calibrated 0-600 psi 0-42 bar.

37045



Auxiliary power cord for use with 300 and 750 l/min testers

No. 37045 – Auxiliary power cord. For use with any 12 or 24 volt battery to remotely power tester. Wt. 0,5 Kg. CAUTION: For use on negative ground systems only.

9785
9786
8987
9788



Hoses

No. 9785 – Hose, 19,1 mm I.D. x 3/4" NPTF male both ends. 3 m length. 155 bar working pressure. (2 req'd on 200 and 300 l/min testers) Wt., 3kg. The following hose assemblies are all 4-ply spiral wound wire, 3 m long. For use with 750 l/min testers.
No. 9786 – Hose, 25,4 mm I.D. x 11/4" NPT male both ends. Recommended max. flow 340 l/min, with a working pressure of 280 bar. Wt., 6,3 kg.

No. 9787 – Hose, 31,8 mm I.D. x 11/4" NPT male both ends. Recommended max. flow 530 l/min, with a working pressure of 210 bar. Wt., 6,4 kg.
No. 9788 – Hose, 38,1 mm I.D. x 11/2" NPT male both ends. Recommended max. flow 750 l/min, with a working pressure of 175 bar. Wt., 11,4 kg.

203264

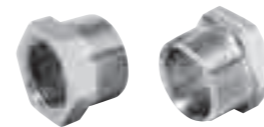

Hose reducer bushings

No. 203264 – Consists of two hose reducer bushings, 11/4" NPT female x 11/2" NPT male end. Needed to adapt No. 9786 25,4 mm I.D. hose and No. 9787 31,8 mm I.D. hose to tester. Wt., 1 kg.

Hydraulic Tester SERVICE ACCESSORIES

Fittings/adapters For the 750 l/min hydraulic tester

Attach to the HT200 hydraulic tester by the use of flanged-head adapters and split flanges, or by a set of female straight adapters.

FLANGED HEAD ADAPTER UNIONS AND SPLIT FLANGE KIT

- No. 203154** – Straight flange adapter. 38,1 mm flanged-head to 11/2" NPSM female swivel. Wt., 1 kg.
- No. 203155** – 45° flange adapter. 38,1 mm flanged-head by 11/2" NPSM female swivel. Wt., 1,5 kg.
- No. 203156** – 90° flange adapter. 38,1 mm flanged-head by 11/2" NPSM female swivel. Wt., 1,9 kg.
- No. 203017** – Split flange kit. Consists of four flange halves and attaching bolts to permit use of 38,1 mm I.D. flange adapters listed at left. Wt., 1,3 kg.

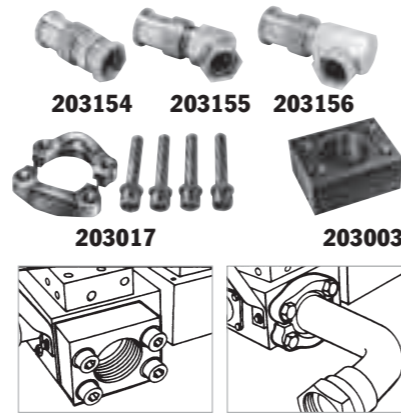

FEMALE STRAIGHT FLANGE ADAPTER

- No. 203003** – Consists of two female straight flange adapters with attaching bolts. When attached to inlet/outlet ports, allows connection of 11/2" NPT male hose ends to tester. Wt., 3,9 kg.

HYDRAULIC FITTINGS FOR USE WITH ALL TESTERS.

	No. 19954 – 90° swivel adapter, 3/4" NPTF male x 3/4" NPSM female. Wt., 0,4 kg.		No. 26073 – Swivel adapter, 3/4" NPTF female x 1/2" NPSM female. Wt., 0,1 kg.
	No. 22041 – Coupler, 3/4" NPTF male x 3/4"-16 female ORB. Wt., 0,2kg.		No. 26074 – 45° swivel adapter, 3/4" NPSM female x 3/4" NPTF male. Wt., 0,3kg.
	No. 22042 – Coupler, 3/4" –16 female ORB x 1 1/16" –12 female 37° JIC. Wt., 0,2kg.		No. 26075 – Swivel adapter, 3/4" NPSM female x 3/4" NPTF female. Wt., 0,2 kg.
	No. 22043 – Coupler, 3/4" –16 female ORB x 9/16" –18 female 37° JIC. Wt., 0,2kg.		No. 26076 – Swivel adapter, 3/4" NPTF male x 3/4" NPSM female. Wt., 0,2kg.
	No. 22044 – Coupler, 3/4" –16 female ORB x 1/2" –20 female 37° JIC. Wt., 0,2 kg.		No. 26077 – Cap, 3/4" NPTF. Wt., 0,3kg.
	No. 27737 – Swivel adapter, 3/4" –16 male x 3/4" NPSM female. For use with No. 9785 hose, which has 3/4" NPTF male thread. Wt., 0,1kg.		No. 26078 – Plug, 3/4" NPTF. Wt., 0,1 kg.
	No. 27287 – Coupler, 3/4" –16 UNF female ORB x 7/8" –14 UNF female 37° JIC. Wt., 0,2kg		No. 26079 – Adapter, 3/4" NPTF female x 1 1/16" –12 male ORB. Wt., 0,2 kg.
	No. 13449 – Cap, 1 1/16" –12 UNF female, 3/4" O.D. tube, 37° flare. Wt., 0,1kg.		No. 208402 – 45° union adapter, 7/8" –14 UNF male 37° JIC x 3/4" NPTF female. 210 bar working pressure. Wt., 0,3 kg.
	No. 26068 – 45° swivel adapter, 1" NPTF male x 3/4" NPSM female. Wt., 0,4 kg.		No. 208401 – 45° union adapter, 7/8" –14 UNF male 37° JIC x 3/4" NPTF female. Wt., 0,4kg.
	No. 26069 – Swivel adapter, 1" NPTF female x 3/4" NPSM female. Wt., 0,2 kg.		No. 206753 – Coupler, 1 1/16" –12 UNF female 37° JIC x 3/4" NPTF female. Wt., 0,5 kg.
	No. 26070 – Adapter, 1" NPTF male x 3/4" NPTF female. Wt., 0,1kg.		No. 26666 – Connector, 1 5/16" –12 UNF male 37° JIC x 3/4" NPTF male. Wt., 0,2 kg.
	No. 26071 – Service tee, 3/4" NPTF female (2) x 3/4" NPTF male. Wt., 0,4 kg.		No. 28984 – Straight adapter, 3/4" NPTF female x 1 3/16" –12 UN male 37° JIC. Wt., 0,3 kg.
	No. 26072 – Swivel adapter, 3/4" NPSM female x 1/2" NPTF male. Wt., 0,2kg.		No. 28985 – Straight adapter union, 1 3/16" –12 UN female 37° JIC x 3/4" NPTF female. Wt., 0,6 kg.

NOTE: The recommended maximum working pressure on the above fittings is 5,000 psi except the 208402.

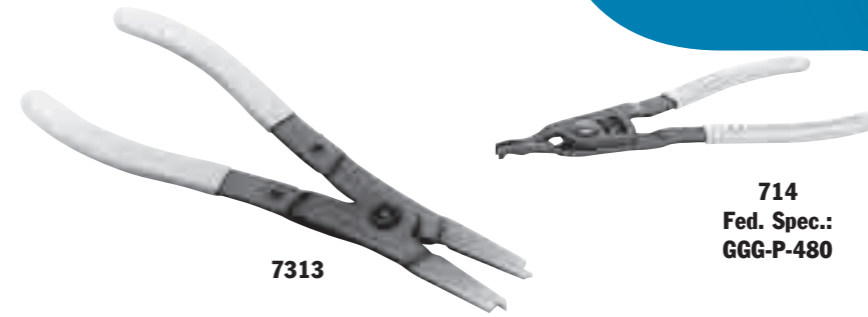

HORSESHOE LOCK RING PLIER

- For removing horseshoe lock rings used on hydraulic brakes, differentials, etc. Plier is 203mm long; max. spread: 23,8mm
- No. 714** – Horseshoe lock ring plier. Wt., 0,2 kg.
- No. 7313** – External snap ring plier easily removes snap rings used to retain bearings on shafts. Max. spread: 27mm.

RETAINING RING PLIER KITS

- Choose from four sets; internal ring, external ring and convertible pliers for either internal or external rings.
- No. 7053K** – Replaceable tip pliers kit. This versatile kit contains (1) internal and (1) external pliers with (8) tip sets. Two sets each: 0,9 mm dia. 90° bend, 1,2 mm dia. straight, 1,2 mm dia. 90° bend, 1,8mm dia. straight. Recommended for 6,4 –51 mm rings. Packaged in plastic storage case. Wt., 0,3 kg.

- No. 15702** – Replaceable tip kit (only for No. 7053K).

- No. 7123K** – Convertible pliers kit. Contains **No. 1120** (1mm dia./straight tip) and No. 1340 (1,8mm dia./straight tip). Each pliers "converts" to handle both internal and external rings. Packaged in a reusable plastic storage case. Wt., 0,4kg.

- No. 7125K** – Convertible pliers kit. Contains **No. 1125** (1 mm dia./45° bent tip) and No. 1345 (1,8 mm dia./45° bent tip). Each pliers "converts" to handle both internal and external rings. Packaged in a reusable plastic storage case. Wt., 0,4kg.

- No. 7406K** – Professional pliers kit. Contains (6) retaining convertible pliers to handle both internal and external rings from 6,4–51 mm. Includes straight and 90° off-set pliers with 1, 1,2, and 1,8 mm tip diameters. Includes Nos. 1120, 1131, 1320, 1329, 1340 and 1349. Packaged in an impact resistant storage case. Wt., 0,9 kg.

Retaining Ring PLIERS

Internal and External

REPLACEMENT TIPS FOR 7300 AND 7301 PLIERS

- No. 209201** – Replacement tips (pr.) for the 7300 and 7301 pliers. Wt., 0,1 kg.

7053K internal & external plier, 4 sizes of tips.



7123K



7406K

RETAINING RING PLIERS SELECTION GUIDE

Plier No	Tip Bend	Tip Size Dia. (mm)	For Int'l Rings* Bore Dia. (mm)	For External Rings* Shaft Dia. (mm)
0100	Str.	1	9,5 – 26	--
0200	Str.	1	--	6,4 – 22
0300	Str.	1,8	27 – 44,5	--
0400	Str.	1,8	--	24 – 36,5
0500	Str.	2,3	46 – 89	--
0600	Str.	2,9	--	38 – 89
7300	Str.	3	78 – 152	--
7301	Str.	3	--	38 – 165
Convertible Pliers				
1120	Str.	1	9,5 – 14	6,4 – 17
1125	45°	1	9,5 – 14	6,4 – 17
1131	90°	1	9,5 – 14	6,4 – 17
1320	Str.	1,2	16 – 26	17 – 22
1329	90°	1,2	16 – 26	17 – 22
1340	Str.	1,8	27 – 44,5	24 – 36,5
1345	45°	1,8	27 – 44,5	24 – 36,5
1349	90°	1,8	27 – 44,5	24 – 36,5

Always wear safety goggles when using pliers

*Capacities are shown for basic style rings.

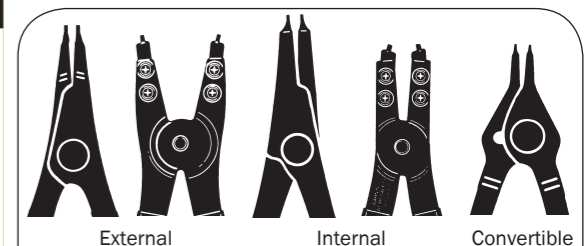

External	Internal	Convertible
No. 0200	No. 0100	No. 1120
No. 0400	No. 0300	No. 1320
No. 0600	No. 0500	No. 1340
		No. 1125*
		No. 1345*
		No. 1131**
		No. 1329**
		No. 1349**

Fed. Spec.: GGG-P-480-E

* 45° Angled Tips ** 90° Angled Tips



3344A

PHOTO TACHOMETER

- Infrared light source, micro-processor controlled crystal display.
- Strong magnetic base is included.

Machine speed: It is critical for proper machining operations. Speeds too fast or too slow can shorten tool life and cause expensive, unnecessary machine downtime. This digital photo tach can take readings from revolving shafts on drill presses, grinders, lathes and other machines. It can also be used to check engine operation on in-plant vehicles like forklifts. The 3344A is

accurate to within ± 1 rpm. The 10mm high liquid crystal display is easily visible even in high ambient light areas.

No. 3344A – Digital Photo Tachometer. With memory, photo probe assembly, magnetic base, 2,75 m of reflective tape and plastic case. Wt., 2 kg.

No. 39811 – Replacement magnetic base assembly. Wt. 0,1kg.

No. 45329 – Replacement photo probe assembly. Wt., 0,2 kg.

No. 204666 – Replacement retro-reflective indicator tape, 2,75 m long x 12,7mm wide. Wt., 0,1 kg.

SPECIFICATIONS

Readout: Liquid crystal display: 4 (10mm high) digits, low battery indicator, memory mode indicator, high and low RPM memory mode indicator.

Range: 200 to 9999 rpm. Accuracy: $\pm .25\%$, ± 1 rpm. Update time: 3/4 second.

Power switch: Membrane switch (automatic shut-off after one minute of no signal input).

Power source: 9 volt alkaline battery. Light source: Infrared with 4,6m plug-in cable.

Light holder assembly: 13,6 kg rated magnet; 50,8 mm dia. x 6,4 mm high (102 mm high overall with post).

Size: 86 w, 152 h x 38 mm d.

Carrying case: 343 w, 254 h x 102 mm d.

HTS50 HEAVY-DUTY PIPE SEALANT WITH TEFLON®

- Seals new or damaged threads; resists water, chemicals and oils.
- Replaces conventional tape methods; forms a clog-free seal. Effective at 700 bar.

When “plumbing” a hydraulic system, there’s now a better answer than tapes which can tear or shred, possibly plugging filters, valves or gauges. This compound combines the lubri-

cating qualities of Teflon® with a fast curing anaerobic sealant. Seals all metal fittings, plugs and threaded joints quickly and easily. Cures to form a permanent seal which is inert to hydrocarbons, most acids, chemicals, solvents and steam. Allows adjustment up to 16 hours after assembly; cannot loosen under vibration. Prevents galling of mating parts upon disassembly. Withstands temperatures from -54° to + 190° C.

No. HTS50 – Sealant, 50 ml. tube. Wt., 0,2 kg.

(Teflon® is a registered trademark of duPont Co.)

HTS50



“O” RING SEAL PICKS

Even the seemingly simple job of removing and installing “O” ring seals can be difficult without the aid of the proper tool. The 7312 all metal “O” ring seal pick does the job with ease. Two special picks in set No. 7103 get right to the trouble areas.

No. 7312 – “O” ring seal pick. Wt., 0,1 kg.

No. 7103 – Set of two “O” ring seal picks. Wt., 0,1 kg.

7312

7103

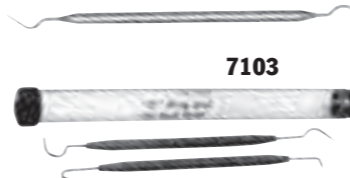

UNIVERSAL OUTSIDE THREAD CHASER

Restore damaged threads on shafts, housings, cages, etc., for re-assembly of matching parts. Eliminates need for thread-cutting equipment. Will not harm threads. V-pads and dies can be replaced. Cap. 32 to 127 mm O.D.

No. 7402 – Thread chaser, complete (with 6 dies: threads per inch – 4, 5, 6, 7, 7½, 8, 9, 10, 11, 11½, 12, 14, 16, 18, 20 and 24). Wt., 0,2 kg.

No. 202817 – Metric die set (3 dies: mm per thread: 1, 1¼, 1½, 1¾, 2, 2½, 3, 3½, and 4). Wt., 0,1 kg.

7402



MAGNETIC PICK-UP TOOL

Has permanent magnetic head for retrieving parts from otherwise inaccessible places.

No. 7395 – Pick-up tool with pocket clip. 152 mm lg. Wt., 0,1 kg.

7395



RATCHETING CHAIN WRENCHES

Special head design allows you to turn wrench in either direction. Ratcheting action makes it possible to re-grip without removal. For parts of most any size and shape.

No. 7400 – Chain wrench, cap. 12,7 to 121 mm O.D. (Capacity= 450 Nm) Wt., 0,9kg

No. 7401 – Chain wrench, cap. 76 to 171 mm O.D. (Capacity= 900 Nm) Wt., 2,3 kg.

No. 209199 – Replacement chain with pin for No. 7400 chain wrench (406 mm long).

No. 209200 – Replacement chain with pin for No. 7401 chain wrench (610 mm long).

ADJUSTABLE HOOK SPANNER WRENCH

Needed wherever turret adjusting nuts or packing gland nuts are used. Cap.: 38 to 102 mm. Handle overall length: 483 mm.

No. 885 – Adjustable hook spanner wrench. Wt., 1,4 kg.

ADJUSTABLE HOOK SPANNER WRENCHES

Replace many fixed-size wrenches... cover range of capacities needed to service industrial tractors and other equipment. Drop-forged jaws adjust to eleven positions for a capacity of 121 to 324 mm O.D. Handle overall length: 610 mm; diameter: 25,4 mm.

No. 7307 – Spanner wrench with one 9,5 mm thick jaw. Wt., 3,3 kg.

No. 7308 – Spanner wrench with two interchangeable jaws: one 9,5 mm thick, one 19 mm thick. Wt., 5 kg

HEAVY-DUTY ADJUSTABLE SPANNER

Extra heavy construction. Has one 19 mm thick, eleven-position hook-jaw for a capacity of 131 to 324 mm O.D. Drop-forged. Handle length: 654 mm; handle dia.: 33,3 mm

No. 7309 – Heavy duty adjustable hook spanner wrench. Wt., 5 kg.

ADJUSTABLE GLAND NUT WRENCH

Designed to handle 51 to 152 mm dia. hydraulic cylinder gland nuts on many construction vehicles. Fits 6,4 and 7,9 mm dia. pin holes; features a 3/4” sq. drive.

No. 1266 – Adjustable gland nut wrench. Wt., 1,4 kg.

No. 204928 – Replacement pin for No. 1266

PRY BARS

Our rolling head pry bars are an extremely popular and useful tool. Head may be used for almost any prying job since a great deal of leverage can be obtained. Long tapered body may be used as a lining-up drift.

No. 7162 – Pry bar; 9,5 mm round, 152 mm long. Wt., 0,1 kg.

No. 7163 – Pry bar; 11,1 mm round, 305 mm long. Wt., 0,3 kg.

No. 7164 – Pry bar; 14,3 mm round, 406 mm long. Wt., 0,5 kg.

No. 7165 – Pry bar; 19 mm round, 457 mm long. Wt., 1 kg.

JIMMY BARS

Ideal for general lifting or prying. Heat treated chrome alloy steel to resist bending or breaking.

No. 7166 – Jimmy bar; 15,9 mm round, 457 mm long. Wt., 0,6 kg.

No. 7167 – Jimmy bar; 19 mm round, 610mm long. Wt., 1,1 kg.

No. 7168 – Jimmy bar; 22,2 mm round, 762 mm long. Wt., 1 kg.

“MAJOR PERSUADER” JIMMY BARS

Two big jimmy bars for big jobs. Forged from chrome alloy steel.

No. 7420 – Jimmy bar; 22,2 mm round, 1.168 mm long. Wt., 3,4 kg.

No. 7421 – Jimmy bar; 25,4 mm round, 1.372 mm long. Wt., 1,9 kg.



PULLERS



Page
...**192**
PULLER BASICS



Page
...**213**
**PROTECTIVE
BLANKETS**



Page
...**196**
POSI-LOCK PULLERS



Page
...**214**
**2/3 JAW PULLERS
GRIP-O-MATIC**



Page
...**200**
**MECHANICAL
JAW PULLERS**



Page
...**215**
**PULLER
ACCESSORIES
GRIP-O-MATIC**



Page
...**202**
**MECHANICAL
PUSH PULLERS**



Page
...**216**
**PULLERS
HYDRAULIC**



Page
...**204**
**PULLING
ATTACHMENTS**



Page
...**220**
**HYDRAULIC
PULLER SETS**



Page
...**206**
**PULLING
SLIDE HAMMER**



Page
...**225**
BEARING PUSHER



Page
PULLER SETS...208



Page
...**226**
UNIVERSAL PULLER



Page
ADAPTERS...210



Page
...**228**
**ROLLER BEARING
PULLER/INSTALLER**



Page
...**212**
**MANUAL
PULLER SETS**



Page
...**230**
**BEARING, BUSHING,
SEAL DRIVERS**



Basics

Puller selection 3 Basic Puller Problems

CONSIDERATIONS:

Determine the type of puller or puller combination. Which puller type is best suited for gripping the part?

Is a combination of puller types required?

Determine the reach needed for your particular pulling problem. The puller you select must have a reach equal or greater than the corresponding sizes of the part to be pulled.

Determine the spread need. The spread

is determined by the width of the part being pulled. The puller's spread should be greater than the width of the part to be pulled.

Estimate the force needed to solve your pulling problem. A puller with the proper reach and spread will usually have enough capacity to remove the corresponding part. When in doubt, always use a puller with a larger capacity than what may be needed. Rusted parts or parts with a large area of resistance may need more pulling force.

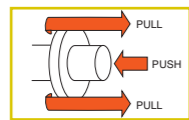

1

PULLING A GEAR, BEARING, WHEEL, PULLEY, ETC., FROM A SHAFT

In order to perform a proper pull, be certain that you firmly grip the gear, bearing, wheel, pulley, etc., and apply force to the shaft. Use a 3-jaw puller, instead of a 2-jaw, whenever possible for better gripping power and a more uniform displacement of pulling force.

RECOMMENDED TOOLS:

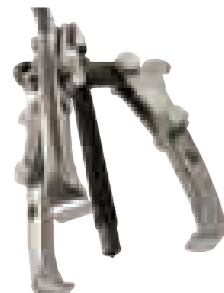

Jaw-type pullers: Either manual or hydraulic. For extra force and convenience, use a hydraulic puller. Both are available in 2 or 3 jaw configurations and are used to grip the outer circumference of a part or can be used with a pulling attachment, such as a bearing/pulley attachment. (pages 196-197, 210-211, 212-213, 222-223)

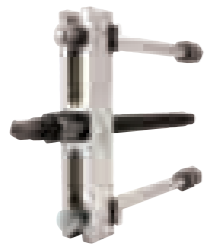

Push-Pullers can thread directly into a threaded part for easy and secure removal. Push-Pullers can be used in conjunction with bearing/pulley attachments which grip the part from behind. A wide assortment of male and female threaded adapters are available as well as metric adapters. (pages 198-199, 214-215)



Slide hammers are best suited for light-duty tasks. Slide hammers can be used for multiple-with pulling problems when combined pulling attachments. (pages 202-204)



Bearing/pulley attachments provide a "knife-like" edge to get behind parts for added versatility and secure removal of parts. Great for parts that don't offer adequate grip with jaw-type pullers. (page 201)



Adapters Whether you need an adapter compatible with any number of threaded hole sizes, protection of part to be pulled or for assisting the installation of a component; Power Team offers a variety of adapters to assist in the removal or installation of parts. (pages 206-207)

2

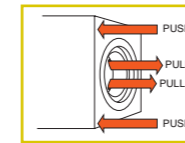

PULLING INTERNAL BEARING RACES, RETAINER, SEALS, ETC.

By extending the narrow jaws of an internal pulling attachment through the center of the part to be pulled, a straight pull is insured, and damage to the housing is avoided. While parts within a "blind hole" in a housing do present a problem, Power Team has the internal pulling attachment or a combination of an internal pulling attachment and puller to handle the situation.

RECOMMENDED TOOLS:



Internal pulling attachments have narrow jaws which extend through the center of the part to be pulled. They provide a straight pull and avoid damaging housings. Internal attachments feature adjustable jaws to fit various diameter parts. (page 204)

Slide hammer with internal attachment is ideal for removing parts from blind holes, especially where there is no housing to brace puller legs against. (pages 206-207)



Push-puller with internal attachment. Push-puller is available in both manual and hydraulic versions. (pages 202-203)



3

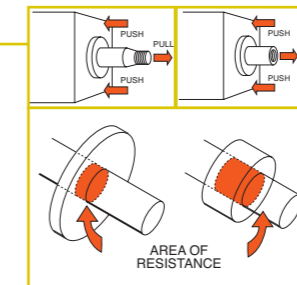

PULLING A PRESS-FITTED SHAFT FROM A HOUSING

Note: Manual pullers require that the shaft being pulled is no more than twice the diameter of the puller's forcing screw. To determine the recommended tonnage for hydraulic pullers, multiply the diameter of the shaft to be pulled by ten. Example: For a 1" shaft, we recommend 10 tons of pulling force.

A shaft with a threaded end can be removed without damage by using one of our slide hammer, manual Push-puller or hydraulic Push-pullers, in conjunction with the proper threaded adapter. Removal is easy! If the shaft to be removed has external threads, simply choose one of our female threaded adapters of proper size/thread. If the shaft has internal threads, simply choose the correct size male

RECOMMENDED TOOLS:



Slide hammer puller matched with a set of threaded adapters is a perfect tool for light duty pulling needs. (pages 206-207, 208-209)

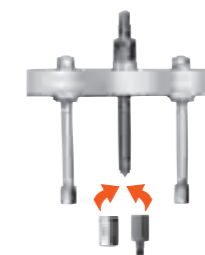

Push-pullers matched with a set of threaded adapters make for an extra versatile pulling tool. (pages 202-203, 210-211, 218-219)

Basics

Puller selection Choosing the Right Puller

WHY OUR ROLLED PULLER THREADS ARE SUPERIOR:

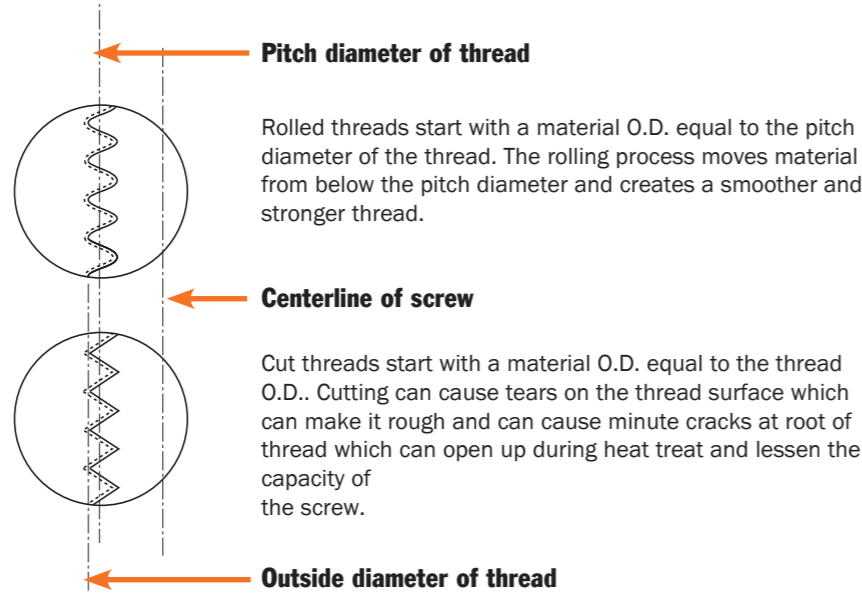

Puller with a bearing pulling attachment was used to take a bearing off a utilities well pump motor.

Features

Benefits

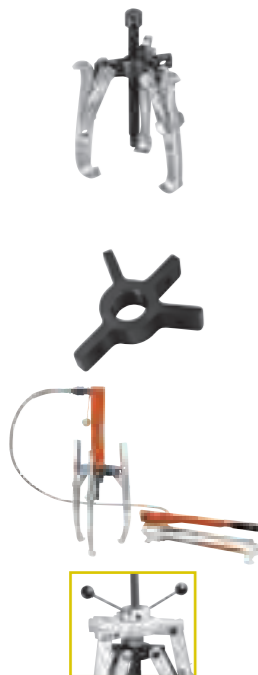

- Grip-O-Matic® feature on jaw type pullers
- 2-way, 3-way and 2/3-way combination pullers
- 1 to 37 ton mechanical pullers
- 5 to 50 ton hydraulic pullers
- 2¹/₈" (54 mm) to 27⁵/₈" (702 mm) reach
- 3¹/₄" (83 mm) to 44" (1,118 mm) of spread
- Forged alloy steel jaws
- Machined puller jaw toes
- Alloy steel heads (forged or flame cut)
- Rolled "V" threads
- Special coating on threads
- Heat treated alloy steel cross bolts
- Standard hydraulic cylinders on Grip-O-Matic® series
- Adjusting nut on Super Grip-O-Matic® series

- The harder the pulling force, the tighter the jaws grip
- A wide variety of pullers; select a specific puller for a specific application or select one or more pullers for general applications
- Strongest possible part; the grain of the material follows the contour of the part.
- Larger and stronger pulling toe than most competitors
- Heat treated and designed for maximum strength
- Stronger and smoother than cut threads
- Resists corrosion, traps lubrication better than black oxide
- Designed for max. shear strength
- Cylinder can be removed from puller and used in other hydraulic applications
- Allows for controlled jaw spread adjustment

NOTE: The puller application photos shown in this catalog are shown without protective blankets for clarity of photos. Power Team strongly recommends you always make your pull with a protective device in place.

Operator safety comes first!

Tons of force are being exerted with your Pulling System. You must respect this force, and observe safety precautions at all times

CAUTION

It is impossible to predict the exact force required for every pulling job: setup requirements and the size, shape and condition of the parts being pulled vary a great deal. In addition, the Power Team Pulling System is so versatile, it is possible that components in a pulling setup may have different tonnage ratings.

The lowest "capacity" component, then, determines the capacity of the setup. For example: When an accessory with a 1 ton capacity is used with a 10 ton capacity puller, the setup can be used only at a force of one ton.

These tools should be used only by trained personnel familiar with them.

Always wear eye protection during a job since work parts, or the pulling tool itself, may break and parts may fly. It is recommended to cover the work with a Power Team Protective Blanket or use a shield while force is being applied. If you are at all unsure which tool or attachment to select, contact the Power Team factory.

A few easy tips to remember:

- 1. Wear safety glasses at all times!** You have only one pair of eyes, so protect them from possible flying parts.
- 2. Keep your pulling tools in shape!** Clean and lubricate the puller's forcing screw frequently, from threads to tip, to assure long service life and proper operation.
- 3. Cover work with a protective blanket!** With high forces being exerted on the part being pulled, breakage may sometimes result. By covering the work with a protective blanket, the mechanic reduces the danger of flying parts.
- 4. Apply force gradually!** The component should give a little at a time. Do not try speed removal by using an impact wrench on the puller screw.
- 5. Use the right size puller!** If you have applied maximum force and the part has not moved, go to a larger capacity puller. Resist sledging.
- 6. Align puller legs and jaws!** Be sure the setup is rigid and that the puller is square with the work.
- 7. Mount puller so grip is tight!** Tighten the adjusting strap-bolts when using a jaw type puller. Always use a 3-jaw puller whenever possible. A 3-jaw puller gives a more secure grip, more even pulling power. Apply force gradually. — Never use an extension on a wrench. — Never use an impact wrench. — Never strike the end of the forcing screw. Always cover work with a protective blanket.
- 8. Do not couple puller legs!** The tonnage capacity of a Push-Puller® is reduced when longer than standard legs are used, or when legs are in compression. The chance of breaking, bending or misaligning legs increases. Keep reach to a minimum. Use shortest legs possible to reach workpiece. Thread legs into workpiece, pulling attachment or adapters evenly. Uneven legs will cause greater pull or push on one side, creating a bending action which could cause damage to work piece or cause a leg to break. The sliding plates must always be on the opposite side of the cross block from the forcing screw nut or hydraulic cylinder. Always cover work with a protective blanket.

Bearing pulling attachments:

These attachments may not withstand the full tonnage of the pullers with which they are used. The shape and condition of the part being pulled affects the tonnage at which the puller blocks and/or studs may bend or break. Always select the largest attachment which will fit the part to be pulled. Always cover work with a protective blanket

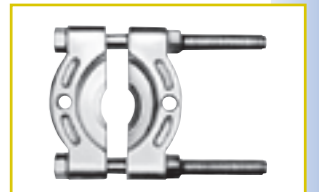
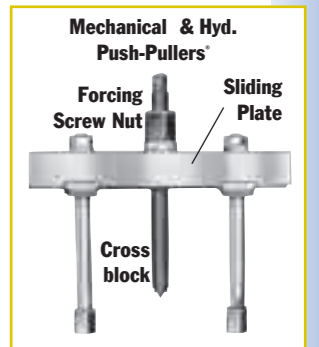



FEATURES & BENEFITS

- Pullers are used whenever there are tough maintenance challenges: Railroads, Steel & Paper Mills, Mines, Oil Fields, Wind Farms, Factories, Power Plants, Shipyards, etc.
- Used to pull a variety of press fit parts from gears to wheels, pulleys to bearings, with minimum effort and without damaging the components or machinery.
- Conventional pullers use manual floppy jaws often require two operators to use and can be time-consuming and slow. Traditional jaws slip off work surfaces or snap back making the pulling operation frustrating and difficult.
- With Power Team - Posi Lock, pulling bearings is a one-man operation. The T-handle and "Safety Cage®" control the jaws at all times. This means that the opening, closing, locking and aligning of the jaws is all done automatically by simply turning the T-handle.
- Hydraulic pullers come with a lift plate for ease of transport and lifting. In addition, ram points of different sizes are available for a variety of applications
- Using a hydraulic puller system adds efficiency and eliminates unsafe practices such as hammering, heating, or prying components to be removed. The cylinder replaces the center bolt function of a manual puller.

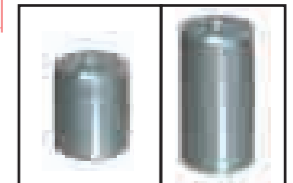
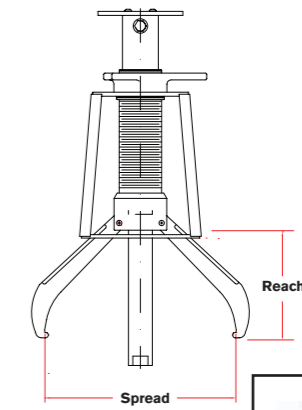

ORDERING INFO

MECHANICAL PULLERS

SPX Part #	Cap (Ton)	# of Jaws	Puller Weight kg	Reach mm	Spread mm	Accessories				
						Long Jaws			Tip Protector	Bolt Extender
						SPX Part #	Reach mm	Spread mm		
PT202	1	2	0.3	57	82.6					
PT204	2	2	1.4	102	127				PTP4	PTX4
PT206	6	2	3.2	152	178				PTP6	PTX6
PT208	12	2	5	203	305	PT11054 / PT11054L	249/406	401/559	PTP10	PTX10
PT210	14	2	6.4	246	381	PT11054L	406	559	PTP10	PTX10
PT213	25	2	13.6	305	457	PT11354L	508	762	PTP13 / PTP16	
PT216	35	2	22.7	356	635	PT11654L	2660	965	PTP13 / PTP16	
PT102	1	3	0.3	57	82.6					
PT103	2	3	0.6	76.2	114.3					
PT104	5	3	1.8	102	127				PTP4	PTX4
PT106	10	3	3.6	152	178				PTP6	PTX6
PT108	17	3	5.9	203	305	PT11054 / PT11054L	249/406	401/559	PTP10	PTX10
PT110	20	3	8.2	246	381	PT11054L	406	559	PTP10	PTX10
PT113	30	3	18.2	305	457	PT11354L	508	762	PTP13 / PTP16	
PT116	40	3	29.5	356	635	PT11654L	660	965	PTP13 / PTP16	

HYDRAULIC PULLERS

SPX Part #	Cap (Ton)	# of Jaws	Puller Weight kg	Reach mm	Spread mm	Accessories					
						Long Jaws			Leveling Arm Bracket Set	Hydraulic Lift Cart	Storage Transport Cart
						SPX Part #	Reach mm	Spread mm			
PTPHA-206	5	2	5.8	152.4	203.2						
PTPHA-208	10	2	6.4	203	305	PT11054 / PT11054L	249/406	401/559			
PTPHA-210	15	2	10	254	381	PTPH-11054L	406	559	PTPH-1210*		
PTPHA-213	25	2	21.3	305	457	PT11354L	508	62	PTPH-1213	PTPT-3050 PTPT-2550	
PTPHA-216	50	2	40.9	356	635	PTPH-21654L	660	965	PTPH-1216	PTPT-3050 PTPT-2550	
PTPHA-106	5	3	6.5	152.4	203.2						
PTPHA-108	10	3	7.3	203	305	PT11054 / PT11054L	249/406	401/559			
PTPHA-110	15	3	11.4	254	381	PTPH-11054L	406	559	PTPH-1110*		
PTPHA-113	25	3	25	305	457	PT11354L	508	762	PTPH-1113	PTPT-3050 PTPT-2550	
PTPHA-116	50	3	45	356	635	PTPH-11654L	660	965	PTPH-1116	PTPT-3050 PTPT-2550	

* Brackets Only

Leveling Arm Bracket



MECHANICAL

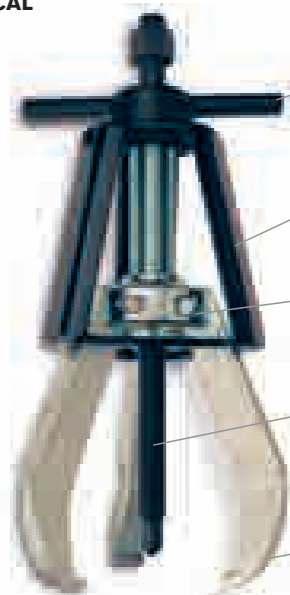

- T-handle facilitates the opening, closing, locking and aligning of the jaws.
- Steel frame guides jaws for fast setup, solid contact, and superior safety
- Leverage up front for vise-like power and no slippage
- Center bolt threads designed for less effort to apply high torque
- Slim tapered jaws allow for easier gripping and better access to tight spots

HYDRAULIC



Posi Lock® is a registered trademark of Posi Lock Puller, Inc.

PTPHB-110



PTPHC-110E



PTPHD-110-E220

Also available in E110



PTPH-100TDA



Features and Benefits:

- 700 bar electric 2 stage pump
- Remote jog switch with 3m cord
- 100 ton cylinder 700 bar with spring return (260.4 mm stroke)
- Hydraulic-actuated lift cart extends puller from ground to a height of 1.5m.
- Jaws are hydraulically controlled with cylinders
- Multiple pushing adapters:
(1) 89mm diameter X 228.6mm
(1) 89mm diameter X 482.6mm
(1) 89mm diameter X 736.6mm
- Removable transport cart
- Puller can be used in horizontal and/or suspended vertical positions
- Adjustable jaw tips
- Adjustable jaw guides

HYDRAULIC BUNDLES †

SPX Part #	Cap (Ton)	# of Jaws	Cylinder Part #	Pump Part #	Gauge Part #	Hose Part #	T Adapter Part #	Coupler	Dust Cap	SPX Part #	Cap (Ton)	# of Jaws	Cylinder Part #	Pump Part #	Gauge Part #	Hose Part #	T Adapter Part #	Coupler	Dust Cap	
PTPHB-206	5	2	C55C							PTPHB-106	5	3	C55C							
PTPHC-206E	5	2	C55C	P19L	9040E	9767E	9670	9798	9800	PTPHC-106E	5	3	C55C	P19L	9040E	9767E	9670	9798	9800	
PTPHD-206-E220	5	2	C55C	PE172-E220	9040E	9769E	9670	9798	9800	PTPHD-106-E220	5	3	C55C	PE172-E220	9040E	9769E	9670	9798	9800	
PTPHD-206-E110	5	2	C55C	PE172-E110	9040E	9769E	9670	9798	9800	PTPHD-106-E110	5	3	C55C	PE172-E110	9040E	9769E	9670	9798	9800	
PTPHB-208	10	2	C106C							PTPHB-108	10	3	C106C							
PTPHC-208E	10	2	C106C	P19L	9040E	9767E	9670	9798	9800	PTPHC-108E	10	3	C106C	P19L	9040E	9767E	9670	9798	9800	
PTPHD-208-E220	10	2	C106C	PE172-E220	9040E	9769E	9670	9798	9800	PTPHD-108-E220	10	3	C106C	PE172-E220	9040E	9769E	9670	9798	9800	
PTPHD-208-E110	10	2	C106C	PE172-E110	9040E	9769E	9670	9798	9800	PTPHD-108-E110	10	3	C106C	PE172-E110	9040E	9769E	9670	9798	9800	
PTPHB-210	15	2	C1510C							PTPHB-110	15	3	C1510C							
PTPHC-210E	15	2	C1510C	P59L	9040E	9767E	9670	9798	9800	PTPHC-110E	15	3	C1510C	P59L	9040E	9767E	9670	9798	9800	
PTPHD-210-E220	15	2	C1510C	PE172-E220	9040E	9769E	9670	9798	9800	PTPHD-110-E220	15	3	C1510C	PE172-E220	9040E	9769E	9670	9798	9800	
PTPHD-210-E110	15	2	C1510C	PE172-E110	9040E	9769E	9670	9798	9800	PTPHD-110-E110	15	3	C1510C	PE172-E110	9040E	9769E	9670	9798	9800	
PTPHB-213	25	2	C2514C							PTPHB-113	25	3	C2514C							
PTPHC-213E	25	2	C2514C	P159	9040E	9767E	9670	9798	9800	PTPHC-113E	25	3	C2514C	P159	9040E	9767E	9670	9798	9800	
PTPHD-213-E220	25	2	C2514C	PE172-E220	9040E	9769E	9670	9798	9800	PTPHD-113-E220	25	3	C2514C	PE172-E220	9040E	9769E	9670	9798	9800	
PTPHD-213-E110	25	2	C2514C	PE172-E110	9040E	9769E	9670	9798	9800	PTPHD-113-E110	25	3	C2514C	PE172-E110	9040E	9769E	9670	9798	9800	
PTPHB-216	50	2	C5513C							PTPHB-116	50	3	C5513C							
PTPHC-216E	50	2	C5513C	P460	9040E	9767E	9670	9798	9800	PTPHC-116E	50	3	C5513C	P460	9040E	9767E	9670	9798	9800	
PTPHD-216-E220	50	2	C5513C	PE172-E220	9040E	9769E	9670	9798	9800	PTPHD-116-E220	50	3	C5513C	PE172-E220	9040E	9769E	9670	9798	9800	
PTPHD-216-E110	50	2	C5513C	PE172-E110	9040E	9769E	9670	9798	9800	PTPHD-116-E110	50	3	C5513C	PE172-E110	9040E	9769E	9670	9798	9800	

† C & D Bundles will include 25599 fitting.

HIGH TONNAGE HYDRAULIC PULLERS

SPX Part #	Cap (Ton)	# of Jaws	Puller Weight (kg)	Reach mm	Spread mm	Jaw Tip Width mm	Tip Clearance mm	Tip Depth	Cylinder Part #	Pump Part #	Gauge Part #	Hose Part #
Single Acting												
PTPH-102T-E220	100	2	772	1270	1778	32	89	89	C10010C	PE552-E220	9040E	9769E
PTPH-102T-E110	100	2	772	1270	1778	32	89	89	C10010C	PE552-E110	9040E	9769E
PTPH-100T-E220	100	3	885	1270	1778	32	89	89	C10010C	PE552-E220	9040E	9769E
PTPH-100T-E110	100	3	885	1270	1778	32	89	89	C10010C	PE552-E110	9040E	9769E
PTPH-123T-E220	100	2/3	908	1270	1778	32	89	89	C10010C	PE552-E220	9040E	9769E
PTPH-123T-E110	100	2/3	908	1270	1778	32	89	89	C10010C	PE552-E110	9040E	9769E
PTPH-102TV-E220*	100	2	817	1270	1778	32	89	89	C10010C	PE552-E220	9040E	9769E
PTPH-102TV-E110*	100	2	817	1270	1778	32	89	89	C10010C	PE552-E110	9040E	9769E
Double Acting												
PTPH-102TDA-E220	100	2	817	1270	1778	32	89	89	RD10013	PE554-E220	9040E	9769E
PTPH-102TDA-E110	100	2	817	1270	1778	32	89	89	RD10013	PE554-E110	9040E	9769E
PTPH-100TDA-E220	100	3	931	1270	1778	32	89	89	RD10013	PE554-E220	9040E	9769E
PTPH-100TDA-E110	100	3	931	1270	1778	32	89	89	RD10013	PE554-E110	9040E	9769E
PTPH-123TDA-E220	100	2/3	953	1270	1778	32	89	89	RD10013	PE554-E220	9040E	9769E
PTPH-123TDA-E110	100	2/3	953	1270	1778	32	89	89	RD10013	PE554-E110	9040E	9769E
PTPH-102DATV-E220*	100	2	817	1270	1778	32	89	89	RD10013	PE554-E220	9040E	9769E
PTPH-102DATV-E110*	100	2	817	1270	1778	32	89	89	RD10013	PE554-E110	9040E	9769E
PTPH-200T-E220**	200	4	1884	1219	1778	32	89	89	CONTACT FACTORY			
PTPH-200T-E110**	200	4	1884	1219	1778	32	89	89	CONTACT FACTORY			
PTPH-200T-E380**	200	4	1884	1219	1778	32	89	89	CONTACT FACTORY			

* Vertical Puller.
** Contact Factory for 200T Hydraulic Puller.

Jaw Pullers

MECHANICAL

2 & 3 Jaw Pullers

Choosing the right size

puller: Compare the "reach" and "spread" of the pulling job with that of the pullers listed. The puller selected must have dimensions greater than those of the job.

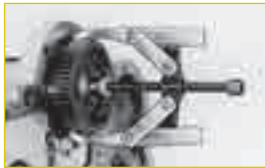
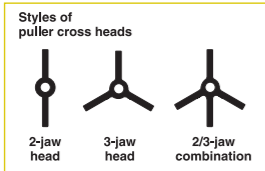

Pulling attachment







Shaft protector

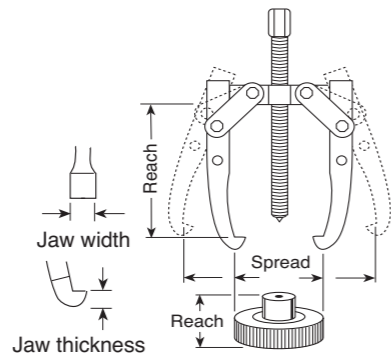

Step plate









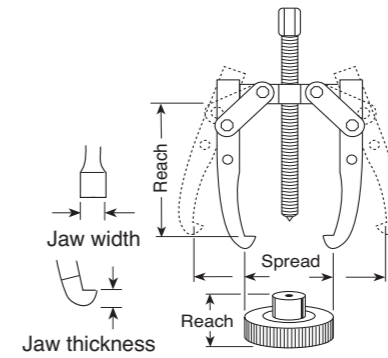



- Lock-Jaw™ feature on all pullers. The harder the pull, the tighter the grip for removing gears, bearings and countless other press fitted parts.
- 2-way, 3-way and 2/3 way combination pullers make it easy to select a specific puller for a specific application.
- Forged from high quality steel, heat treated and subjected to rigorous tests which exceed rated puller capacity.
- Meets Fed. Spec.: GGG-P-00781-D



Order No.	Max. Reach (mm)	Max. Spread (mm)	Screw Size (in.)	Jaw		Capacity, Style and Weight
				Thickness (mm)	Width (mm)	
1020  1021 	54	82,6	5/16-24 x 98,4 mm	3,5	6,4	1-Ton, 2-Jaw; 0,14 kg
1021						1-Ton, 3-Jaw; 0,23 kg
1022  1023 	85,7	101,6	3/8-24 x 124 mm	Upper 4,8 Lower 3,2	Upper 6,4 Lower 12,7	2-ton, 2-Jaw; 0,4 kg (Reversible Jaws)
1023						2-ton, 2/3-Jaw; 0,6 kg (Reversible Jaws)
1024  1026 	83	152	9/16-20 x 176 mm	Upper 7,9 Lower 6,4	Upper 9,5 Lower 19,1	5-Ton, 2-Jaw; 0,8 kg (Reversible Jaws)
1026						5-Ton, 2/3-Jaw; 1,3 kg (Reversible Jaws)

- Alloy steel heads are forged for maximum strength.
- Forcing screw threads are rolled, not cut. This process creates a smoother and stronger thread.
- Heat treated alloy steel cross bolts for maximum shear strength.
- Machined puller jaw toes produce larger and stronger pulling toes.



Order No.	Max. Reach (mm)	Max. Spread (mm)	Screw Size (in.)	Jaw		Capacity, Style and Weight
				Thickness (mm)	Width (mm)	
1025  1027 	140	152	9/16-20 x 176 mm	Upper 7,9 Lower 6,4	Upper 9,5 Lower 19,1	5-Ton, Long 2-Jaw; (Reversible Jaws), 0,9 kg
1027						5-Ton, Long 2/3-Jaw; (Reversible Jaws), 1,5 kg
1035  1037 	127	229	1 1/16-18 x 229 mm	Upper 7,9 Lower 8,7	Upper 25,4 Lower 25,4	7-Ton, 2-Jaw; (Reversible Jaws), 2 kg
1037						7-Ton, 2/3-Jaw (Reversible Jaws), 2,8 kg
1036  1038 	222	241	1 1/16-18 x 229 mm	8,7	25,4	7-Ton, Long 2-Jaw, 2,3 kg
1038						7-Ton, Long 2/3-Jaw, 3,3 kg
1039/1040  1041/1042 	279	318	1 3/16-16 x 305 mm	14,3	25,4	13-Ton, 2-Jaw, 4,8 kg
1040						13-Ton, Long 2-Jaw, 5,9 kg
1041						13-Ton, 2/3-Jaw, 6,7 kg
1042						13-Ton, Long 2/3-Jaw, 8,3 kg
1043/1044  1045/1046 	368	356	1-14 x 343 mm	20,6	32,5	17,5-Ton, lang; 2-Jaw, 8,3 kg
1044						17,5-Ton, Long 2-Jaw, 11,8 kg
1045						17,5-Ton, 3-Jaw, 15 kg
1046						17,5-Ton, Long 3-Jaw, 16,8 kg
1048  1050 	565	508	1 1/4-12 x 422 mm	27	38,1	25-Ton, Long 2-Jaw, 19,4 kg
1050						25-Ton, Long 3-Jaw, 27,2 kg

For puller piece part identification, order Power Team parts catalog PC97

Mechanical PUSH PULLERS

10, 17½, &
30 Ton Cap.

For removing and installing gears, bearings, pulleys and other press-fitted parts.

Fed. Spec.: GGG-P-00781-D

- Can apply a pushing or pulling force, depending on how the puller is set up.
- Optional leg kits adapt your Push-Puller® to extra long or extra short reach.
- A wide variety of threaded adapters, bearing pulling attachments and internal pulling attachments can be used in combination with our Push-Pullers.®

Selection and capacity rating – Each Push-Puller's specified tonnage "capacity" is determined using its standard legs in tension. Using longer legs, or a setup in which the legs are in compression, will reduce the "capacity". Always select the largest "capacity" puller and the shortest legs that will fit the job.

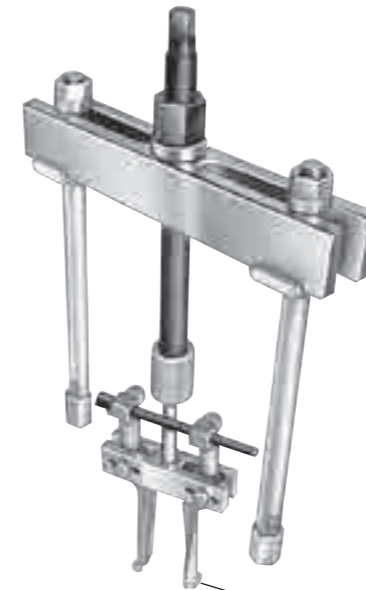
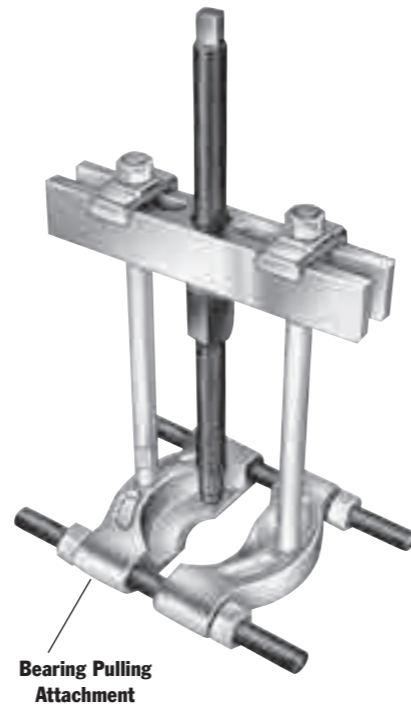

No. 927 – 10-Ton Capacity can be used with No. 1123 bearing pulling attachment or No. 679 pulley pulling attachment. May also be used with Nos. 1150, 1151, 1152, or 1153 internal pulling attachments.

No. 938 – 17½-Ton Capacity can be used with Nos. 1124 and 1130 bearing pulling attachments or Nos. 679 and 680 pulley pulling attachments. May also be used with Nos. 1150, 1151, 1153, 1165, or 1166 internal pulling attachments.

No. 939 – 30-Ton Capacity can

be used with Nos. 1126 and 1127 bearing pulling attachments or No. 680 pulley pulling attachment (two 8012 adapters are required to connect 680 to puller). Can be used with No. 1165 internal pulling attachment.

ASSEMBLING THE TOOL TO APPLY PUSHING OR PULLING FORCE:

1. Determine if you want the tool's forcing screw to push or pull.
2. To exert pushing force, the forcing nut is installed beneath the cross block, as shown on left.
3. To cause the forcing screw to pull, the forcing nut is placed on top of the cross block.
4. The sliding plates must always be placed on the opposite side of the cross block from the forcing nut.

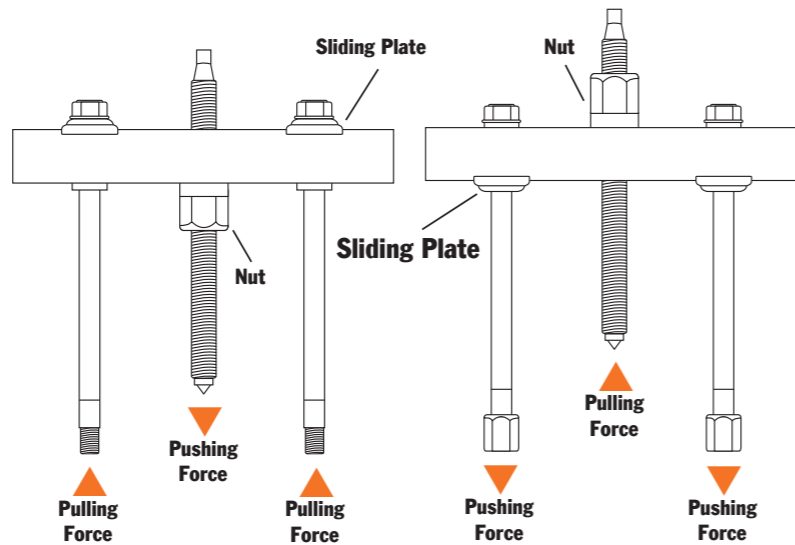

Available Adapters (page 214-215)

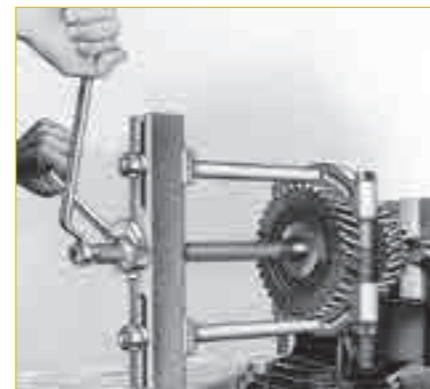
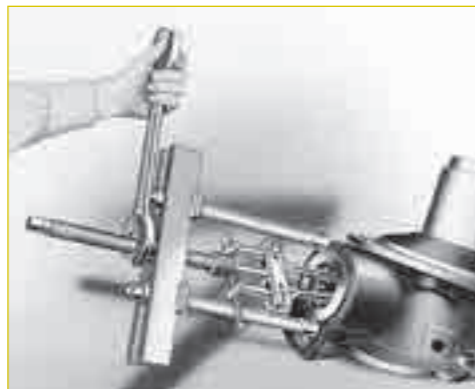

927

Max. Reach	Max. Spread	Screw	Size	Notes / Weight
210 mm	54 - 184 mm	¾" - 16 x 305 mm		1/2" of forcing screw tip end is threaded 5/8" - 18. No. 1100 legs and No. 24827 leg ends included. Wt., 3,2 kg.
Order No.	Leg Length & Wt.		Order No.	Leg Length & Wt.
1103	121 mm, 0,45 kg		1102	298 mm, 1 kg
1100	171 mm, 0,7 kg		1101	400 mm, 1,5 kg
Extra Legs (pair) for No. 927 Push-Puller (Reach equals leg length plus 50,8 mm with leg end caps.)				

938

Max. Reach	Max. Spread	Screw	Size	Notes / Weight
282 mm	79 - 298 mm	1" - 14 x 336 mm		Leg ends threaded 5/8" - 18. No. 1106 legs and No. 24827 leg ends included. Wt., 9,4 kg
Order No.	Leg Length & Wt.		Order No.	Leg Length & Wt.
1107	114 mm, 1,1 kg		1105	572 mm, 4,1 kg
1106	241 mm, 2 kg		1108	762 mm, 5,2 kg
1104	419 mm, 3 kg			
Extra Legs (pair) for No. 938 Push-Puller (Reach equals leg length plus 50,8 mm with leg end caps.)				

939

Max. Reach	Max. Spread	Screw	Size	Notes / Weight
267 mm	178 - 413 mm	1½" - 12 x 438 mm		Leg ends threaded 1" - 14. No. 1109 legs and No. 28390 leg ends included. Wt., 20 kg
Order No.	Leg Length & Wt.		Order No.	Leg Length & Wt.
1109	203 mm, 3,6 kg		1111	711 mm, 10 kg
1110	457 mm, 6,8 kg			
Extra Legs (pair) for No. 939 Push-Puller (Reach equals leg length plus 66,7 mm with leg end caps.)				

Pulling ATTACHMENTS

38,1 - 228 mm Jaw Spreads

Recommended for the removal of bearings, bearing cups, bushings and oil seals.

- Handles internal pulling jobs, such as, bearing/bearing cup removal, bushing removal, oil seals, etc.
 - Remove hard to get at parts easily and without damage!
 - Use with corresponding Power Team Slide Hammer or Push-Puller.®
 - Adjustable jaws fit various diameters
- Fed. Spec.: GGG-P-00781-D**

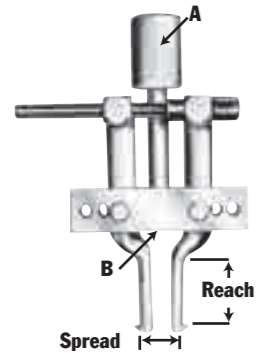

CAUTION – These attachments may not withstand the full tonnage of the pullers they are used with. The shape and condition of the part being pulled affects the tonnage at which the jaws may slip off. Always select the largest attachment which will fit behind the part being pulled. Refer to page 195.

Order No.	Jaw Spread (mm)	Reach (mm)	A (in. - thd.)	B (in. - thd.)	Wt. (kg)	Application
1153	38,1-127	54	1-14	5/8-18	1,9	Use with Nos. 927 and 938 Push-Pullers,
1150	38,1-152	102	1-14	5/8-18	2	
1151	38,1-178	133	1-14	5/8-18	2	
1152	38,1-152	102	-	5/8-18	1,6	Use with Nos. 927 and 938 Push-Pullers, 1155 and 1156 slide hammer pullers, or 24832 and 24833 puller screw.
1154	38,1-152	102	1-8	5/8-18	2	Use with No. PPH17.
1165	76,7-229	149	1 1/2-12	1-14	6,1	Use with No. 939 Push-Puller.
1166	76,2-229	149	1 1/4-7	1-14	6,1	Use with No. PPH30.
Puller Screws						
24832	349 mm long		5/8-18	0,5		Use with Nos. 1150, 1151, 1152, and 1153. Acts as a regular forcing screw when threaded directly into block of pulling attachment.
24833	140 mm long		5/8-18	0,2		Use with Nos. 1150, 1152, and 1153. Acts as a regular forcing screw when threaded directly into block of pulling attachment.

Pulling ATTACHMENTS

Bearing & Pulley

Used where space does not permit hooking puller jaws directly on part to be pulled.



- “Knife-like” edges fit behind bearings and other hard-to-grip parts for easy removal, even where clearance is limited.
 - Usable with both Grip-O-Matic® jaw type pullers and Push-Pullers®.
 - All puller blocks are made from forged alloy steel
- Fed. Spec.: GGG-P-00781-D**

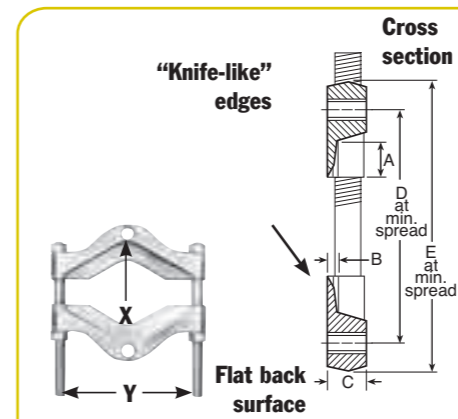

Attachment clamps down into V-groove to distribute load. Use with Grip-O-Matic® pullers or Push-Pullers.

X = Thread of tapped hole in adapter.
Y = Distance between adjusting screws.

Order No.	Max. Spread (mm)	X (in.)	Y (mm)	A (mm)	B (mm)	C (mm)	D (mm)	E (mm)	Wt. (kg)	Application - (Use with Puller Nos.)
1121	6,4-22,2	5/8-18	43	11,1	3,2	12,7	34,9	50,8	0,3	1020, 1022, and 1023.
1122	3,2-51	3/4-16	62	11,1	4,0	15,9	50,8	69,9	0,6	1024, 1025, 1026, 1027, 7392 and 7393.
1123	9,5-117	3/4-18	111	22,2	9,5	25,4	88,9	114,3	2,3	1035, 1036, 1037, 1038, and 927.
1124	12,7-133	3/4-18	152	34,9	11,1	31,8	127	158,8	5,4	1039, 1040, 1041, 1042, PH172, PPH17, and 938.
1126	16-203	1-14	181	34,9	17,5	34,9	146,1	190,5	9	1047, 1043, and 939.
1127	19-340	1-14	260	44,5	17,5	44,5	158,8	215,9	18,8	1047, 1073, and 939.
1128	127-327	1 1/4-12	330	44,5	19,1	57,2	327	406	45,4	PH553C and PPH50. (When using 1128 with PPH50, two 8024 adapters are required to connect PPH50 to the puller tees.)
1130	12,7-219	3/4-18	152	34,9	11,1	31,8	127	158,8	5,4	1039, 1040, 1041, 1042, PH172, PPH17, and 938.
V-belt pulley pulling attachments										
679	45-149	3/4-18	152						2	1035, 1036, 1037, 1038, and 927.
680	42,3-254	3/4-18	257						10,1	1039, 1040, 1041, 1042, 1047, PH172, PPH30* and 938. (When using 680 with PPH30, two 8012 adapters are required.)

Pulling attachment accessory – “Knife-like” edges of attachment fit behind bearings or other parts for easy removal with “Enforcer 55”, even if space does not permit hooking puller jaws directly to part being pulled.
No. 1128 – Spread: 127 to 327 mm. Wt., 45,5 kg.

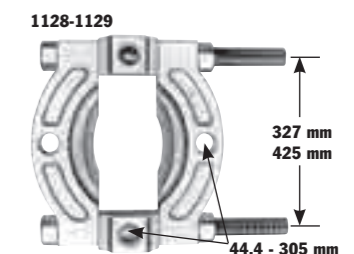

CAUTION: Please refer to page 195.

Pullers

SLIDE HAMMER

Blind hole puller set – Removal of bearings, bushings, sleeves and other friction-fitted parts from blind holes can now be accomplished with ease. Set provides selection of expanding collets 8 to 44,5 mm I.D. Collet is placed through bore of part to be removed, then expanded with actuator pin so that lips of collet secure a positive grip for pulling. Pulling force is exerted by means of a forcing screw and bridge assembly or with a slide hammer.

No. 981 – Blind-hole puller set with slide hammer, forcing screw, bridge, actuator pins, collets, and storage box. Wt., 9,5 kg.



Set No. 981

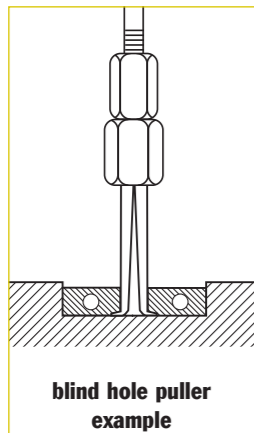

blind hole puller example

Order No.	Description	Order No.	Description
24835	Forcing Screw	28253	Actuator Pin (5 mm dia.)
24836	Forcing Screw Nut	28256	Actuator Pin (12,7 mm dia.)
22185	Hammer 1,1 kg.	41331	Bridge
208627	Shank & Tee Bar Assembly	28323GY8	Metal Box
28250	Actuator Pin (3,2 mm dia.)	10419	Metal Box

Order No.	Inch Range	MM Range	Order No.	Inc Range	MM Range
33856*	5/16" to 3/8"	8 to 9.5	33861**	3/4" to 7/8"	19.1 to 22.2
33857*	3/8" to 7/16"	9.5 to 11.1	33862**	7/8" to 1"	22.2 to 25.4
33858**	7/16" to 1/2"	11.1 to 12.7	33863***	1" to 1 1/4"	25.4 to 31.7
33859**	1/2" to 5/8"	12.7 to 15.9	33864**	1 1/4" to 1 1/2"	31.7 to 38.1
33860**	5/8" to 3/4"	15.9 to 19.1	33865***	1 1/2" to 1 3/4"	38.1 to 44.4

*Use with 3 mm actuator pin. **Use with 4,8 mm actuator pin. ***Use with 12,7 mm actuator pin

Slide hammer puller set – This very handy set is ideal for those close-quarter, inside pulling jobs. Very practical for pulling motor, generator, and magneto bearings. Also good for removing small-bore bushings, bearings, and oil seals.

No. SS2 – Slide hammer puller set. Wt., 2,6 kg.

Jaw Set	Inside Spread	Min. (mm)		Max. (mm)	
		Min.	Max.	Min.	Max.
1172		12,7	50,8		
1174		12,7	34,9		

Slide hammer puller set – This useful set contains a reversible-jaw slide hammer puller with a 1,1 kg sliding hammer plus an assortment of special jaws (3 of each size) and adapters. In this set, you get all the versatility you demand of a slide hammer puller.

No. 1178 – Slide hammer puller set with 1,1 kg. sliding hammer. Wt., 6,3 kg.

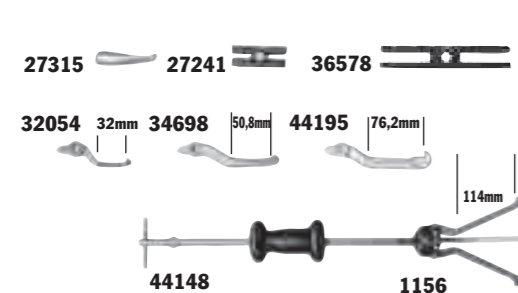

Jaw	2-Jaw Spread				3-Jaw Spread			
	Inside		Outside		Inside		Outside	
	Min. (mm)	Max. (mm)	Min. (mm)	Max. (mm)	Min. (mm)	Max. (mm)	Min. (mm)	Max. (mm)
44195	38,1	114,3	19,1	127	38,1	120,7	25,4	114
32054	19,1	60,3	–	–	25,4	69,9	–	–
44148	69,9	139,7	19,1	191	82,6	158,8	25,4	159
34698	31,8	88,9	25,4	114	38,1	108	38,1	114

Sliding hammers only -

No. 22185 – 1,1 kg sliding hammer.

No. 34331 – 2,3 kg sliding hammer.



Bearing cup remover – The 7136 is perfect for pulling internal bearing cups, seals, bushings, etc. Jaw spread – 23,8 to 82,6 mm, reach to 88,9 mm. Use with any slide hammer having 5/8"-18 thread (Power Team 1155, 1156 or 927 Push-Puller®).

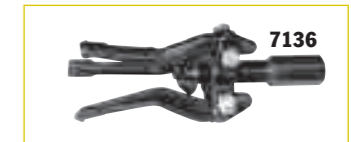

No. 7136 – Universal bearing cup remover. Wt., 0,7 kg.

Pilot bearing pullers – These very versatile pullers are built especially for inside pulling jobs, and particularly for removing flywheel pilot bearings on machines and construction vehicles. Also very practical for pulling motor, generator and magneto bearings.

Special slide hammer puller – Ideal for pulling jobs in very close quarters, as in removal of small-bore bushings,

bearings, oil seals, etc. Internal pulling attachment has jaw spread of 12,7 to 35

mm. Handle end has a 1/2"-20 thread.

No. 1173 – Slide hammer puller. Wt., 1,6 kg.

No. 1174 – Puller head, less slide hammer.

Basic slide hammer units – Compatible with internal pulling attachment (see page 198). Compatible with threaded adapters (see page 204-205). 610 mm length, 5/8"-18 threaded end.

No. 1155 – Basic slide hammer unit with 2,3 kg hammer. Wt., 3,3 kg.

No. 1156 – Basic slide hammer unit with 1,1 kg hammer. Wt., 2,2 kg.

Reversible-jaw slide hammer pullers – Ideal for pulling gears, bearings, outer races, grease retainers, oil seals, etc. Two or three jaws may be used and positioned for "inside" or "outside" pulling jobs. Both have 5/8"-18 threaded end so attachments and adapters may be used.

No. 1176 – Slide hammer puller with 1,1 kg hammer, 27241 two-way head and 34698 jaws. Wt., 3,3 kg

No. 1177 – Same as 1176 but with 2,2 kg hammer. Wt., 4,8 kg

Order No.	Reach	Min.	I.D. Spread		Wt.
			Min.	Max.	
1170	19,1	12,7	38,1	2,2	
1171	25,4	22,2	54	2,2	
1172	44,5	12,7	50,8	2,2	

Order No.	Jaw Set	Inside Spread		Prod. Wt. (kg)	Overall Length (mm)
		Min. (mm)	Max. (mm)		
1176		12,7	50,8	3,3	686
1177		12,7	34,9	4,8	686

Order No.	Min. (mm)	2 Jaw Spread		3 Jaw Spread		Prod. Wt. (kg)	Overall Length (mm)				
		Inside	Outside	Inside	Outside						
1176	31,8	88,9	25,4	114	38,1	108	38,1	114	3,6	686	
1177	31,8	88,9	25,4	114	38,1	108	38,1	114	4,8	686	

Slide hammer pullers with cup pulling attachments – These combine a basic slide hammer with No. 1152 internal pulling attachment for removing oil seals, outer races, and bearing cups from blind holes.

No. 1157 – Slide hammer puller consisting of 1156 slide hammer and 1152 internal pulling attachment.

No. 1158 – Same as 1157 but with 1155 slide hammer.

Order No.	Reach (mm)	Spread (mm)	Spread (mm)	Prod. Wt. (kg)	Overall Length (mm)
1157	102	38,1	152	4,5	711
1158	102	38,1	152	5,6	711



Puller Sets

Convenient, portable puller sets that go where you do.



10 ton capacity Push-Puller® set – Contains three popular Power Team bar-type pullers in one versatile set, packed in a handy plastic storage case. Tools included permit damage-free pulling of gears, bearings, harmonic balancers, and other parts having tapped holes. Ideal for servicing off-road construction equipment and machinery.

Multi-purpose puller set – This new assortment of pulling tools gives you a wide range of job versatility. You get a 2,2 kg slide hammer puller, hub puller, two sizes of Power Team Grip-O-Matic® jaw-type pullers, a bearing pulling attachment plus a cross-bar gear and pulley puller, all contained in a handy plastic storage case.

Lock-on, jaw-type puller set – Components can be assembled to create several versatile puller versions. The puller head is turned to securely lock the jaws onto the part being removed. Both a 2-way and 3-way puller head are included, plus three long-reach and three short-reach puller jaws in a plastic storage box. Easily removes gears, bearings and other press-fitted parts.

Puller Sets STRONG BOX

10 Ton Cap Push-Pullers®, 2/3 Jaw Pullers & Specialty Pullers

Have the puller you need on hand, when you need it, protected from unauthorized users.

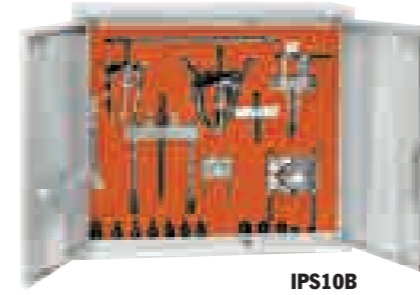

10 ton capacity Strong Box puller set – Here's a set of pullers that gives you almost unheard of versatility. This rugged, lockable metal storage cabinet contains pullers, attachments and extra puller jaws good for a variety of applications. Cabinet may be mounted on a wall, stand, or workbench.



IPS10B



10 ton capacity hydraulic/manual puller set in Strong Box – This lockable metal Strong Box contains both hydraulic and manual pullers, plus attachments. The rugged storage cabinet keeps the tools organized and secure from unauthorized borrowers!

IPS10HB

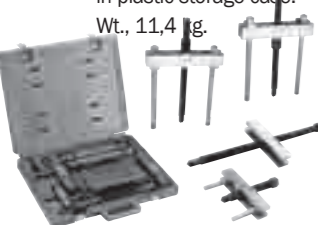
- Have the puller you need on hand, when you need it, protected from unauthorized or casual borrowers.
- Almost unheard of versatility
- Rugged, lockable storage cabinet.
- Wall, stand or workbench mountable.

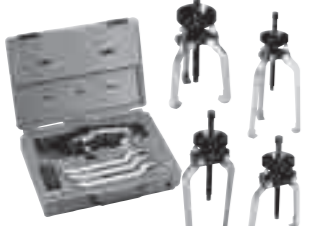
Order No.	Set Contents	Description																			
1180 	927	10 Ton Push-Puller®; 213 mm reach, 54 to 184 mm spread. Comes with 171 mm puller legs, other leg sizes are available separately (See page 197).																			
	522	Gear and pulley puller; spread range when used with 12,7 mm cap screws: 50,8 to 197 mm. Cap screws not included.																			
	7393	Gear and pulley puller with standard 140 mm forcing screw, plus special 330 mm forcing screw. Includes two hex head cap screws, 3/8"-16 x 76,2 mm long. Spread range: 38 to 180 mm.																			
1181 	1177	Slide hammer puller with 2,2 kg hammer, 2-way and 3-way heads. Reversible: either two or three jaws may be used to handle both "inside" and "outside" pulling jobs.																			
	7208	Hub puller. Includes a spare locknut which permits use with No. 1177 slide hammer.																			
	1023	2 ton combination 2- or 3-jaw Grip-O-Matic® puller. Has 86 mm max. reach, 121 mm max.																			
	1027	5 ton combination 2- or 3-jaw Grip-O-Matic® puller. Has 140 mm max. reach, 178 mm max. spread.																			
	7393	Bar-type gear and pulley puller with 140 mm long screw. Includes two hex head cap screws, 3/8"-16 x 76 mm long. Spread range: 38 to 108 mm.																			
	1122	Bearing pulling attachment for use with No. 1027 and No. 7393 pullers. Has 50,8 mm max. spread, 3 mm min. spread.																			
1182 	<table border="1"> <thead> <tr> <th rowspan="2">Puller Jaws Order</th> <th colspan="2">2-Jaw</th> <th colspan="2">3-Jaw Spread</th> </tr> <tr> <th>Inside* Min. (mm)</th> <th>Max. (mm)</th> <th>Inside* Min. (mm)</th> <th>Outside Max. (mm)</th> </tr> </thead> <tbody> <tr> <td>44195</td> <td>38</td> <td>114</td> <td>19</td> <td>127</td> </tr> <tr> <td>44148</td> <td>70</td> <td>140</td> <td>19</td> <td>191</td> </tr> </tbody> </table>		Puller Jaws Order	2-Jaw		3-Jaw Spread		Inside* Min. (mm)	Max. (mm)	Inside* Min. (mm)	Outside Max. (mm)	44195	38	114	19	127	44148	70	140	19	191
	Puller Jaws Order	2-Jaw		3-Jaw Spread																	
		Inside* Min. (mm)	Max. (mm)	Inside* Min. (mm)	Outside Max. (mm)																
	44195	38	114	19	127																
	44148	70	140	19	191																

* Can be used for internal pulling tasks when used with a slide hammer.

Order No.	Set Contents	Description
IPS10B Cabinet (654 x 749 x 254 mm) with tool board, adapter board, and tool set. Wt., 44,5 kg.	927	10 ton capacity Push-Puller® with 172 mm legs
	1027	5 ton combination 2/3-jaw puller
	1037	7 ton combination 2/3-jaw puller
	1101	400 mm puller legs (pair)
	1122	Bearing pulling attachment
	1123	Bearing pulling attachment
	1152	Internal pulling attachment
	7393	Gear and pulley puller
	8005, 8006, 8007, 8010	Male/female threaded
	8013, 8015, 8019	Adapters (2 ea.)
	8035, 8037, 8038, 8039, 8040	Female threaded adapters
	8050 thru 8053	Shaft protectors
	8057 thru 8062	Step plate adapters
	43892	Long jaws for 1037 (3)
212867	Cabinet, tool board and adapter board	
IPS10HB Cabinet (654 x 749 x 254 mm) with tool board, pullers, and hydraulics. Wt., 44,5 kg.	*PH103C	10 ton combination 2/3-jaw hydraulic puller
	1027	5 ton combination 2/3-jaw puller
	1042	13 ton combination 2/3-jaw puller
	1177	Slide hammer puller
	44148	3 jaws for slide hammer puller (114 mm)
	44195	3 jaws for slide hammer puller (76 mm)
	36578	Slotted cross head for slide hammer puller
	27315	Seal hook for slide hammer puller
	1152	Internal pulling attachment (38 to 152 mm spread)
	24832	Forcing screw for 1152
215315	Cabinet and tool board	

* See page 212.

Adapters

Specialty Pullers & Metric

Gear and pulley pullers – Ideal for pulling many small parts having tapped holes. The Nos. 7392 and 7393 may be used with the No. 1122 pulling attachment to remove bearings, etc. Pullers include two hex head cap screws, 3/8" – 16 NC x 76 mm long. Spread: 38 – 108 mm. Width of puller block is 124 mm. Cap screws are not included with the No. 522, but any cap screws up to 12,7 mm diameter may be used. No. 522 spread, when used with 12,7 mm dia. cap screws, is 51–197 mm. Width of the No. 522 puller block is 209 mm.

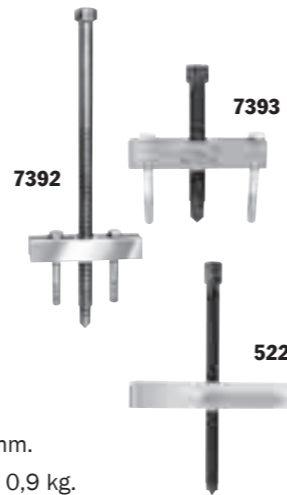

- No. 7392** – Puller with 5/8"-18 x 330 mm long screw. Wt., 0,9 kg.
- No. 7393** – Puller with 5/8"-18 x 140 mm long screw. Wt., 0,7 kg
- No. 522** – Puller with 3/4"-16 x 295 mm long screw. Wt., 2 kg

4-in-1 puller set – You can quickly assemble a 2- or 3-jaw puller with standard or long reach jaws.

No. PA7 – Four-In-One puller set, 7 ton capacity. Standard jaw max. reach is 127 mm. Maximum spread is 267 mm. Long jaw maximum reach is 222 mm. Maximum spread is 279 mm., 4,9 kg

Flange type puller – Slotted holes in puller body permit cap screws to be positioned to handle bolt-circle diameters from 38 –117 mm.

No. 518 – Flange type puller. Includes 3 cap screws, 3/8" – 24 NF x 76 mm long and 3 cap screws 3/8" – 16 NC x 76 mm long. Forcing screw is 5/8"-18 x 127 mm long Wt., 1,5 kg.

Metric adapters – Add metric capability to your Push-Puller® legs or forcing screws! Four separate metric kits available with a variety of sizes for your Push-Puller® legs or forcing screws! Each packaged in a convenient plastic organizer case.

PULLERS



Order No.	Kit Contents	Female End	Male End	Length (mm)	Order No.	Kit Contents	Female End	Male End	Length (mm)
No. 8110 Male Metric Wt., 1,4 kg	8111	5/8"-18	M6 x 1.0	57,2	No. 8120 Male Metric Wt., 1,3 kg	8121	5/8"-18	M14 x 1.5	57
	8112	5/8"-18	M8 x 1.0	57,2		8122	5/8"-18	M14 x 2.0	57
	8113	5/8"-18	M8 x 1.25	57,2		8123	5/8"-18	M16 x 1.5	70
	8114	5/8"-18	M10 x 1.25	57,2		8124	5/8"-18	M16 x 2.0	70
	8115	5/8"-18	M10 x 1.50	57,2		8125	5/8"-18	M20 x 1.5	70
	8116	5/8"-18	M12 x 1.25	57,2		8126	5/8"-18	M20 x 2.5	70
	8117	5/8"-18	M12 x 1.75	57,2					

Note: The adapters in each of these sets are also available separately.

Female threaded adapters - Use these adapters on the ends of Push-Puller® forcing screws, legs, or slide hammers in the removal and installation of shafts, axles, and housings.

Set No. 8044 – consists of a set of 6 adapters (Nos. 8037-8042)

Order No.	Female End "A"	Female End "B"	Order No.	Female End "A"	Female End "B"
8035*	1/2"-20	5/8"-18	8040	5/8"-18	1"-14
8036*	1"-14	1"-14	8041	5/8"-18	1 1/8"-12
8037	5/8"-18	5/8"-18	8042	5/8"-18	1 1/4"-12
8038	5/8"-18	3/4"-16	8043*	5/8"-18	1 1/2"-12
8039	5/8"-18	7/8"-14			

Note: All adapters available separately.

*Not included in set No. 8044. Order separately.

Male-female threaded adapters – These adapters are used on ends of Push-Puller® legs, with forcing screws or slide hammers to assist in pulling shafts, bearing caps, pinions, and many other parts.

Order No.	Female End	Male End	Length (mm)	Order No.	Female End	Male End	Length (mm)
8000	5/8"-18	1/4"-20	57,2	8015	5/8"-18	3/4"-10	57,2
8001	5/8"-18	5/16"-18	57,2	8016	1"-14	3/4"-10	63,5
8002	5/8"-18	7/16"-14	57,2	8017	5/8"-18	7/8"-14	57,2
8003	5/8"-18	7/16"-20	57,2	8018	5/8"-18	7/8"-9	57,2
8004	5/8"-18	3/8"-24	57,2	8019	5/8"-18	1"-14	57,2
8005	5/8"-18	3/8"-16	57,2	8020	1"-8	5/8"-18	76,2
8006	5/8"-18	1/2"-20	57,2	8021	1"-8	1"-14	76,2
8007	5/8"-18	1/2"-13	57,2	8022	5/8"-18	1/8" pipe	57,2
8008	5/8"-18	9/16"-18	57,2	8023	1 1/4"-12	1"-14	114,3
8009	5/8"-18	9/16"-12	57,2	8024	1 1/4"-12	1 3/4"-12	114,3
8010	5/8"-18	5/8"-11	57,2	8025	1 1/4"-7	5/8"-18	101,6
8011	1"-14	5/16"-11	63,5	8027	1 1/4"-7	1"-14	101,6
8012	1"-14	5/8"-18	81	8028	1 5/8"-5 1/2	1"-8	101,6
8013	5/8"-18	3/4"-16	57,2	8029	1 5/8"-5 1/2	1"-14	101,6
8014	1"-14	3/4"-16	63,5				

Note: Nos. 8000–8029 – each sold individually.

Step plate adapter sets – Power Team step plate adapters are necessary for pulling and installing bearings, gears, or other parts on hollow shafts or housings. Puller screw forces against step plate adapter, as shown at right. May be used with Power Team jaw-type pullers, Push-Pullers® and shop presses.

Set No. 8075 – set of 11 adapters (Nos. 8057-8067).

Set No. 8076 – set of 6 adapters (Nos. 8068-8073).

Order No.	Set No. 8075		Order No.	Set No. 8075		Order No.	Set No. 8076	
	Dia. "A" (mm)	Dia. "B" (mm)		Dia. "A" (mm)	Dia. "B" (mm)		Dia. "A" (mm)	Dia. "B" (mm)
8057	25,4	19,1	8063	47,5	38,1	8068	66,5	53,8
8058	28,4	22,1	8064	50,8	41,1	8069	69,9	57,2
8059	31,8	25,4	8065	53,8	44,5	8070	72,9	60,3
8060	34,8	28,4	8066	60,2	47,5	8071	76,2	63,5
8061	41,1	31,8	8067	63,5	50,8	8072	82,6	69,9
8062	44,5	34,8				8073	88,9	76,2

Shaft protector set -- Power Team shaft protectors are designed to protect shaft centers from distortion when extreme pressures are applied with jaw-type pullers or Push-Pullers®. Shaft protectors are inserted between the end of the puller screw and the shaft.

Set No. 8056 – Set of 6 shaft protectors (Nos. 8050 thru 8055).

Order No.	"A" (mm)	"B" (mm)	"C" (60°) (mm)	"D" (60°) (mm)	Order No.	"A" (mm)	"B" (mm)	"C" (60°) (mm)	"D" (60°) (mm)
8050	38,1	19,1	9,4	11,1	8053	19,1	19,1	6,4	6,4
8051	31,8	19,1	9,4	9,4	8054	15,7	15,7	6,4	6,4
8052	25,4	19,1	9,4	7,9	8055	15,7	15,7	4,8	4,8

CAUTION: All the items shown may not withstand the full tonnage of the pullers they may be used with. Refer to page 195.

PULLERS

Puller Sets

MANUAL

10 & 17½ Ton

10 ton manual puller set – This puller set is just what you need for removing gears, bearings, etc. Includes pullers, attachments, and many accessories.



IPS10M

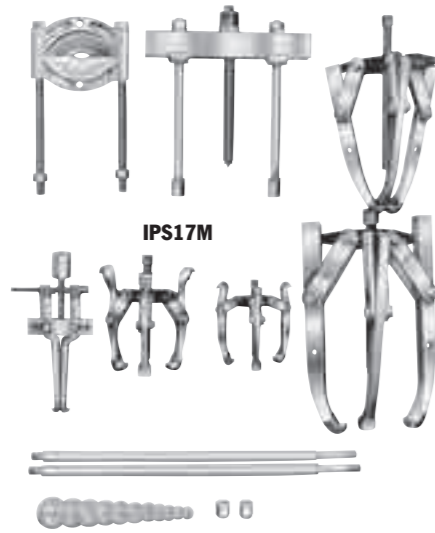

IPS17M

17½ ton manual puller set – The pullers and accessories in this set can be used for hundreds of applications including quick and easy maintenance involving removal and replacement of press-fit parts.

Manual Puller Set No. Order No.	Set Contents		Set Accessories	
	Contents	Pullers	Contents	Accessories
IPS10M 10 ton capacity Wt., 24 kg.	927	10 ton capacity Push-Puller® with 171 mm legs	8075	Step plate adapter set
	1023	2 ton combination 2/3-jaw puller	8044	Female threaded adapter set
	1026	5 ton combination 2/3-jaw puller	8035	Female threaded adapter: ½"–20 x ⅝"–18
	1027	5 ton combination 2/3-jaw puller	1151	Bearing cup pulling attachment
	1037	7 ton combination 2/3-jaw puller	1121	Bearing pulling attachment
	1178	Slide hammer set	1122	Bearing pulling attachment
IPS17M 17½ ton capacity Wt., 52,7 kg.	938	17½ ton capacity Push-Puller® with 241 mm legs	8075	Step plate adapter set
	1027	5 ton combo 2/3-jaw puller, with long jaws	1105	572 mm legs for 938
	1037	7 ton combination 2/3-jaw puller	1130	Bearing pulling attachment
	1041	13 ton combination 2/3 jaw puller	1151	Bearing cup pulling attachment
	1045	17½ ton 3-jaw puller	8038	Female adapter: ⅝"–18 F. x ¾"–16 F. (2)

Protective Blankets and Security Chests

Power Team protective blanket – Our blankets are designed to contain broken or flying parts from the most extreme forces, thus resulting in a much safer work environment.



PB1230C

Testing results – In our lab, this style of blanket held the parts of a necked-down grade 8 bolt, which shattered in a 100 ton center-hole hydraulic cylinder. The blanket sustained no visible damage when shot with a force and impact that shattered safety glasses!

- Effectively contain broken or flying parts from the most extreme pulling, pressing, pushing or stressing forces.
- Ideal for use with pullers and forcing presses.
- Made of see-through, high-tensile, tear resistant material.
- Unlike rigid, fixed guards, these blankets can be wrapped and strapped around a job.
- The clear protective blankets allow you to visually monitor the job from start to finish.
- Protective blankets come in a carrying/storage pouch to reduce aging caused by prolonged exposure to light.

Protect yourself and your equipment.



Order No.	Size (mm)	Number of Straps	Wt. (kg)
PB1230C	305 x 762	2	1,3
PB2036C	508 x 914	2	1,9
PB2860	711 x 1.524	3	4,2
PB3372C	838 x 1.829	3	5,3
PB44120C	1.118 x 3.048	4	10,9
PB51156C	1.295 x 3.962	4	15,5



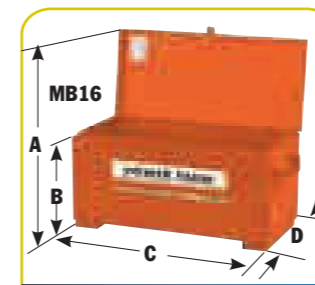

Note: Custom sizes are available on a special order basis. Please consult factory.

Job-site and maintenance security chests – Protect your valuable tools and equipment from theft and weather. When the day's work is finished, you want to rest assured that your tools and equipment will be present the next day. In these times, security is a real concern. These rugged, lockable chests are the answer that many of our customers have been asking for.



- Rugged, 1,6 mm steel construction with fully arc welded seams for extra strength and weather protection.
- Full length piano hinges, mating cover to body, protect against weather and theft.
- Single or double latch security tabs for padlocks.
- Mechanical cover supports, two 57 mm high skirts.
- Fold-down 19 mm pipe handles on each end of chest.
- Pre-drilled for optional casters, which enhance mobility.
- Durable baked enamel finish.

Order No.	Dimensions				Storage		Optional Caster Wheels
	A (mm)	B (mm)	C (mm)	D (mm)	Cap. (cu. m)	Wt. (kg)	
MB5	883	356	813	483	0,14	30	No. 251646 – Set of four 102 mm casters (two swivel and two rigid). Furnished with mounting screws. Wt., 5,7 kg. 
MB8	1.010	483	1.670	483	0,25	40,9	
MB16	1264	610	1.219	610	0,45	57,2	No. 251647 – Set of four 152 mm casters (two swivel and two rigid). Furnished with mounting screws. Wt., 7 kg. 

Hydra Grip-O-Matic® USE WITH 2/3 JAW PULLERS

6, 8, 11 & 30 Ton

A self contained pulling system in a compact package

PULLERS

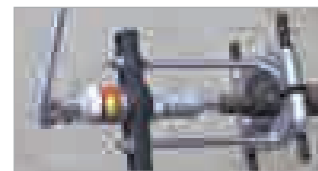

- You get the world's most copied puller design; the harder the pulling force, the tighter the jaws grip for secure holding force.
- Power Team pullers are tested for top performance and reliability at maximum capacity and jaw spread.
- Removing a wide variety of gears, bearings, bushings, pulleys and other press-fitted parts becomes a routine task.
- Easily metered release valve control knob.
- Spring loaded live centering cone.
- Bladder type oil reservoir.
- Rapid adjustment.
- Use with 2 or 3 jaws.
- Supplied with a sturdy storage/carrying case.
- Features Power Team's exclusive Marathon Limited Lifetime Warranty

Hydra Grip-O-Matic® pulling system - These pullers are ideal for pulling a wide variety of press-fitted parts including bushings, bearings, wheels, gears and pulleys. Applications can be found in a wide variety of industries as well. Grip-O-Matic® pullers have been rigorously tested for top performance and reliability. PH82K is a complete pulling system which includes a hydraulic power module, 2-way puller head, jaws, legs and bearing splitter attachment; all contained in a convenient carrying case.

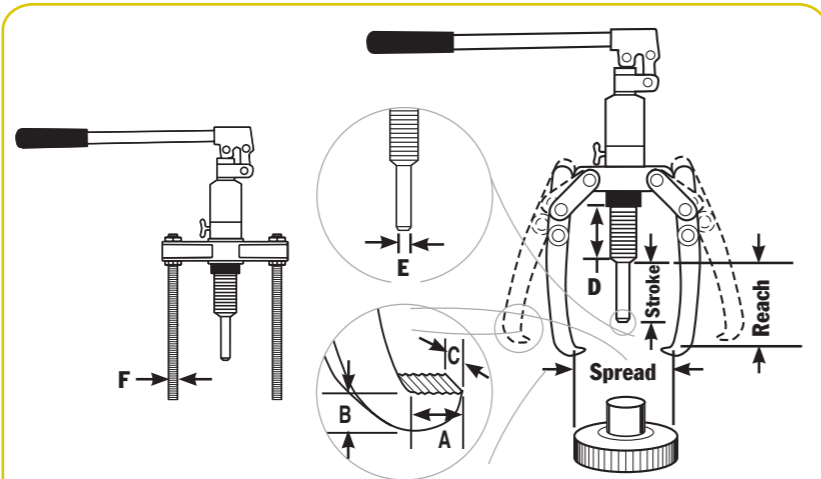
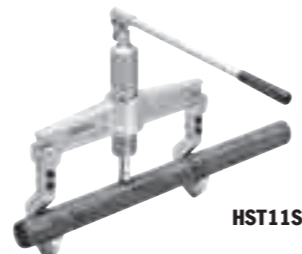

Cyl. Cap. (tons)	Order No.	Reach		Min. Reach (mm)	Max. Studs (mm)	Spread Jaws (mm)	Stroke (mm)	A (mm)	B (mm)	C (mm)	D (mm)	E (mm)	F (in.)	Wt.
		Studs (mm)	Jaws (mm)											
6	PH63C	--	152	--	--	200	80	11	6,4	22	83	22	--	4,9
8	PH83C	--	190	--	--	249	80	11	9,5	25,4	83	22	--	6,6
15	PH113C	--	229	--	--	280	80	14,3	9,5	29	83	29	--	8,0
30	PH303C	266,7	375	--	--	540	110	27	36,5	38	170	54	--	32,3
8	PH82K	266,7	207	125	300	245	80	52	25,4	26	83	22	5/8-18 UNF	9,5
11	HST11S	--	150	--	--	102-410	80	--	--	--	65	29	--	14,5

Puller

Accessories



Hydra Grip-O-Matic® puller accessory kits – K82 accessory kit for the Hydra-Grip-O-Matic® puller No. PH83C. Includes 2-way puller head, 2 jaws, 2 threaded legs and sturdy carrying/storage case.

No. K82 – Accessory kit for PH83C Grip-O-Matic® hydraulic puller. K83 2/3 way head accessories kit for a Hydra Grip-O-Matic® puller No. PH83C. Includes 2/3 way puller head, 3 jaws, 3 threaded legs (5/8-18 thread) and sturdy carrying/ storage case. Also can be used with 1123, 1124, 1130 pulling attachments.

No. K83 – Accessory kit for PH83C Grip-O-Matic® hydraulic puller.

Puller Accessory converts PH113C into a Hydraulic Straightening Tool – Portable...Good for straightening mechanical shafts, round bars, etc. Simply remove pump and cylinder from puller head and insert them into the straightening tool accessory. This product is widely used in steel mills, wire roll companies, wire extruding companies, textile industry, and any straightening situation where portability and power are required. Contoured heat-treated shaft adapter included.

No. HST11 – Spread: 89 to 410 mm, Reach: 150 mm. Wt., 9,5 kg.

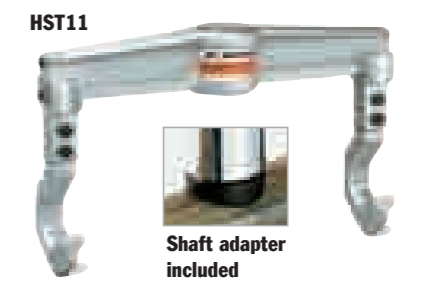

Long jaw set for PH83C and PH113C Grip-O-Matic® pullers – This long jaw set is the perfect addition to the PH83C or PH113C Grip-O-Matic® hydraulic pullers. The extra long jaws give you the added capability of pulling a wider variety of parts. Jaw capacity is 8 tons when used with the PH83C puller; 15 tons when used with the PH113C puller.

No. 1188 – Spread: 280 to 317 mm, Reach: 317 mm.



PULLERS

Pullers HYDRAULIC

5, 10, 17½, 30 & 50 Ton

PULLERS

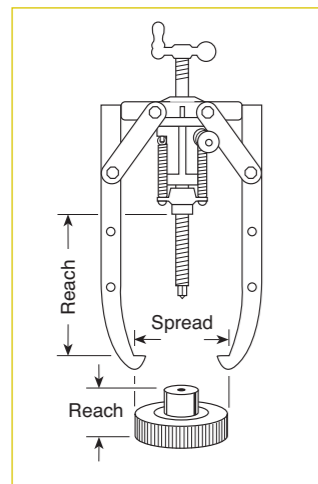

- Remove gears, bearings, and other press-fitted parts with speed and ease.
- Broad capacity range of 5, 10, 17½, 30 and 50 tons.
- 5 and 10 ton sets include: single-acting, spring return hydraulic cylinder with hose, coupler and dust cap; single-speed hydraulic hand pump; puller.
- 17½, 30 and 50 tons sets include: Power-Twin® single acting, spring return hydraulic cylinder with hose, coupler and dust cap; single-speed hydraulic hand pump; puller, adjusting screw and crank.
- Hydraulic cylinder of all models is readily removable from puller for use with pump in other hydraulic applications. You get maximum maintenance versatility for your investment.

Fed. Spec.: GGG-P-00781-D

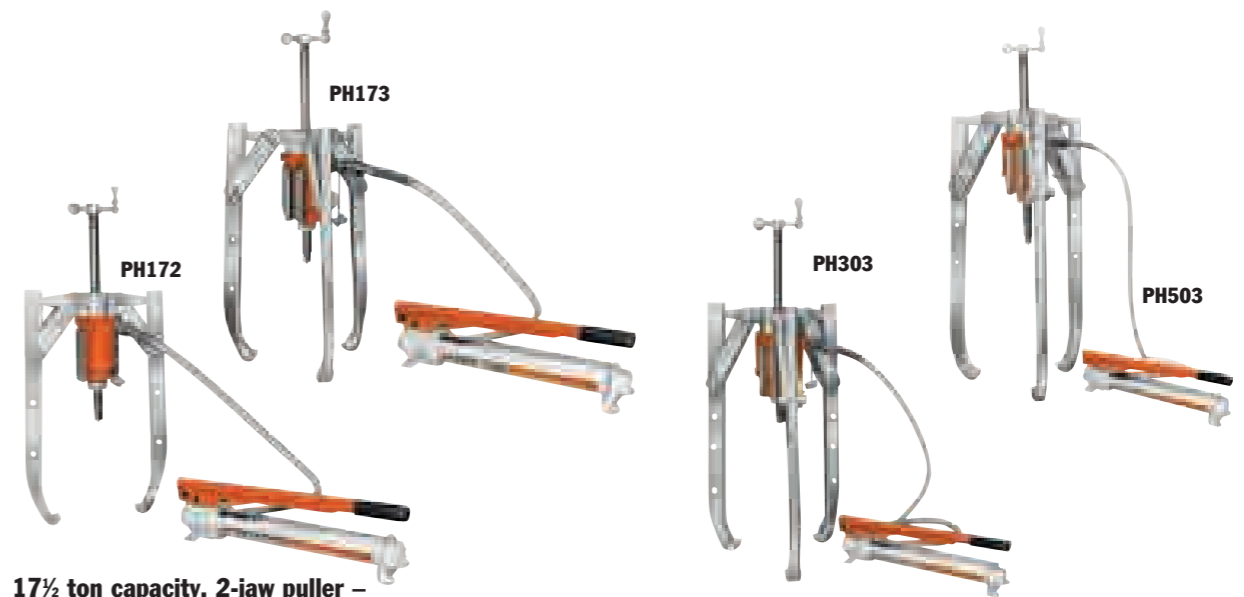
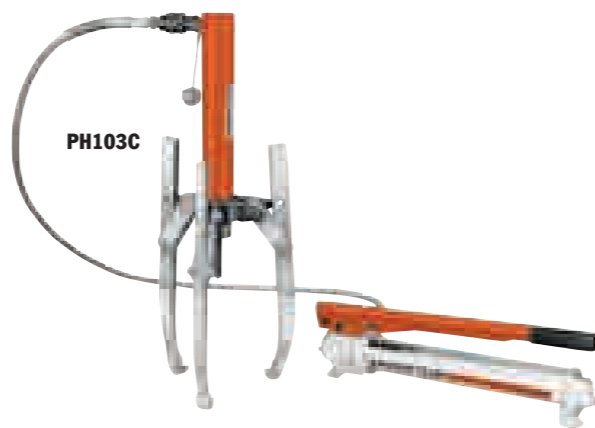

17½ ton capacity, 2-jaw puller –

- No. PH172** – 2-jaw puller with RT172 center-hole Power-Twin® cylinder, cylinder half coupler, P55 pump, 1,8 m hose, hose half coupler, 1” – 8 x 508 mm long adjusting screw, and adjusting crank. Wt., 27,7 kg.
- No. 1064** – Puller only. (Cylinder, pump, hose, coupler, screw, and crank not included). Wt., 10 kg.

17½ ton capacity, 3-jaw puller –

- No. PH173** – 3-jaw puller with RT172 center-hole Power-Twin® cylinder, cylinder half coupler, P55 pump, 1,8 m hose, hose half coupler, 1” – 8 x 508 mm long adjusting screw, and adjusting crank. Wt., 34 kg.
- No. PH173R** – 3-jaw puller with screw and crank, and RT172 center-hole twin cylinder. Wt., 25,4 kg.
- No. 1066** – Puller only. (Cylinder, pump, hose, coupler, screw, and crank not included). Wt., 16,3 kg.

30 ton capacity, 3-jaw puller –

- No. PH303** – 3-jaw puller with RT302 center-hole Power-Twin® cylinder, cylinder half coupler, P55 pump, 1,8 m hose, hose half coupler, 1½” – 7 x 610 mm lg. adjusting screw, and adjusting crank. Wt., 67,7 kg.
- No. PH303R** – 3-jaw puller with screw and crank, and RT302 center-hole twin cylinder. Wt., 59 kg.
- No. 1074** – Puller only. (Cylinder, pump, hose, coupler, screw, and crank not included). Wt., 40,9 kg.

50 ton capacity, 3-jaw puller –

- No. PH503** – 3-jaw puller with RT503 center-hole Power-Twin® cylinder, cylinder half coupler, P55 pump, 1,8 m hose, hose half coupler, 1¾” – 51/2 x 772 mm long adjusting screw, and adjusting crank. Wt., 130 kg.
- No. 1080** – 3-jaw puller only. (Cylinder, pump, hose, coupler, screw, and crank not included). Wt., 86,7 kg.

5 ton capacity, 2/3 jaw puller –

- No. PH53C** – Combination 2-jaw/3-jaw puller set. Includes 1057 5 ton puller, RPS55 hydraulic set (C55C cylinder, P12 700 bar hand pump, fittings, coupler, and 1,8 m hose), and 309874 pushing adapter. Wt., 9,1 kg.
- No. PH53CR** – Combination 2-jaw/3-jaw puller set. Includes 1057 5 ton puller, C55C cylinder, and 309874 pushing adapter. Wt., 5,5 kg
- No. 1057** – 5 ton cap. 2-jaw/3-jaw puller only. Wt., 3,5 kg.

Available components -

- No. 309874** – 15,9 mm diameter pushing adapter. (Included with PH53C and PH53CR hydraulic puller sets.) Wt., 0,3 kg.
- No. 309875** – 22,2 mm diameter pushing adapter. Wt., 0,3 kg.
- No. 47997** – 2-way/3-way puller head. (Can be used to convert No. 1038 7 ton manual puller into a 5 ton hydraulic puller.) Wt., 1,1 kg.

10 ton capacity, 2/3 jaw puller -

- No. PH103C** – Combination 2-jaw/3-jaw puller; 10 ton capacity. Set includes 1060 10 ton puller, RPS1010 cylinder and pump set, 202179 threaded adapter, and 34602 pushing adapter. Wt., 23,6 kg.
- No. PH103CR** – Combination 2-jaw/3-jaw puller, 10 ton capacity. Set includes 1060 10 ton puller, 202179 threaded adapter, 34602 pushing adapter, and C1010C cylinder only. (Pump and hose not included.) Wt., 14,5 kg.
- No. 1060** – Combination 2-jaw/3-jaw puller only; 10 ton capacity. (Cylinder and pump set, hose, coupler, and adapter No. 202179 not included.) Wt., 7,7 kg.

NOTE: This puller may be used with any 10 ton single-acting cylinder having a 2¼” – 14 straight collar thread.

PULLER ONLY

Order No.	Cap. (Tons)	Jaws	Jaw Reach (mm)	Jaw Spread (mm)	Jaw Thickness (mm)	Jaw Width (mm)	Wt. (kg)
1057	5	2/3	222	292	8,7	25	3,5
1060	10	2/3	381	432	14,3	25	7,7
1064	17½	2	292	406	20,6	32,5	10
1066	17½	3	292	508	20,6	32,5	16,3
1074	30	3	494	864	28,6	41,3	40,9
1080	50	3	702	1.118	35,7	47,6	86,7

▲ CAUTION: Always use a 3-jaw puller where clearance permits in order to provide a more stable setup and a more even pulling force.

PULLERS

Push-Pullers® HYDRAULIC

17½, 30-50 Ton

The power to make impossible jobs become routine.

- Can apply a hydraulic pushing or pulling force, depending on how the puller is set up.
- Each unit includes perfectly matched hydraulic components that can be detached from the Push-Puller® for other tasks requiring dependable Power Team power; assuring maximum return on your investment.
- Optional leg kits adapt your Push-Puller® to extra long or extra short reach.
- A wide variety of threaded adapters, bearing pulling attachments and internal pulling attachments can be used in combination with our Push-Pullers®.



30 ton capacity Push-Puller® -

No. PPH30 – Push-Puller® with RT302 center-hole Power Twin® cylinder, cylinder half coupler, P55 pump, 9767 1,8 m. hose, 9798 hose half coupler, 457 mm legs, 28390 leg ends, 1½"-7 x 610 mm lg. adjusting screw and adjusting crank. Wt., 46,3 kg.

No. PPH30R – Same as above, but without P55 pump, 9767 1,8 m hose and 9798 hose half coupler. Wt., 37,2 kg.

No. 1070 – Puller only. (Cylinder, pump, hose, coupler, screw and crank not included.) Wt., 19,1 kg.

USE WITH:

Bearing pulling attachments: **No. 680** (Use two 8012 adapters to connect to puller.)

Pulley pulling attachment: **No. 679.**

Internal pulling attachment: **No. 1166.**

Legs: **Nos. 1109, 1110 and 1111** - Pair of legs for 30 ton "capacity" Push-Puller®.

50 ton capacity Push-Puller® -

No. PPH50 – Push-Puller® with RT503 center-hole Power Twin® cylinder, cylinder half coupler, P55 pump, 9767 1,8 m hose, 9798 hose half coupler, 610 mm legs, 1½"-5½" x 722 mm lg. adjusting screw and adjusting crank. Wt., 91,3 kg.

No. PPH50R – Same as above, but without P55 pump, 9767 1,8 m hose and 9798 hose half coupler. Wt., 82,2 kg.

No. 1076 – Puller only. (Cylinder, pump, hose, coupler, screw and crank not included.) Wt., 48,1 kg.

USE WITH:

Bearing pulling attachments: **Nos. 1128 and 1129.**

Legs: **Nos. 1112 and 1113** - Pair of legs for 50 ton "capacity" Push-Puller®.

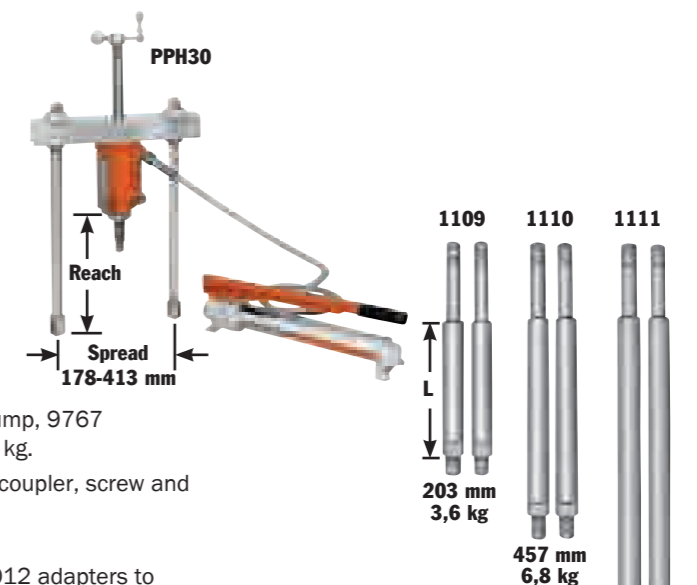

Note: L = leg length: 203, 457 and 711 mm; subtract 149 mm from leg length to determine reach when using leg end caps.

Leg ends are threaded 1"-14 x 32 mm lg.

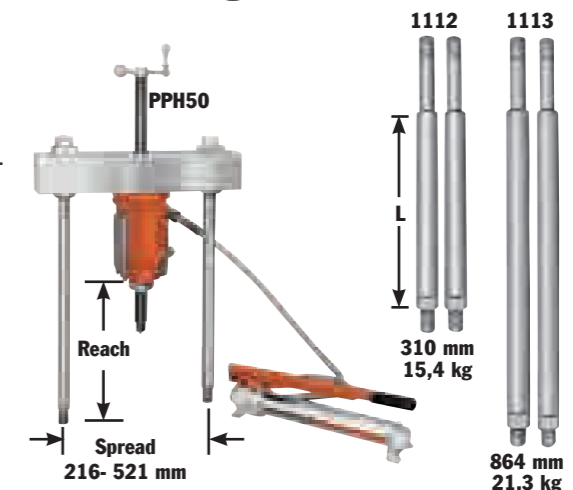

Leg ends are threaded 1½"-12 x 44,5 mm lg.

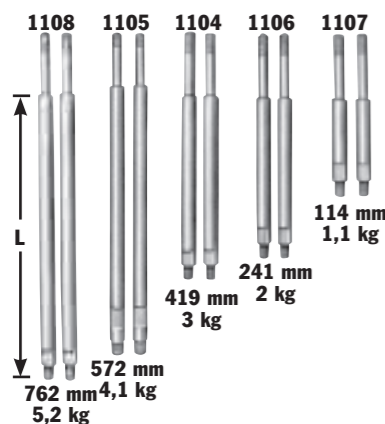
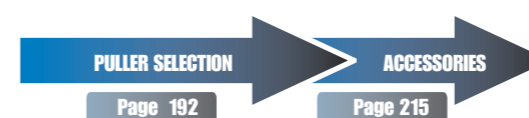
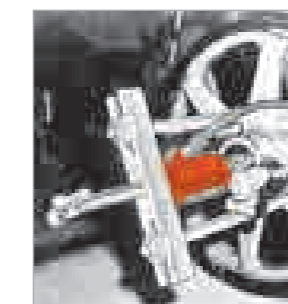
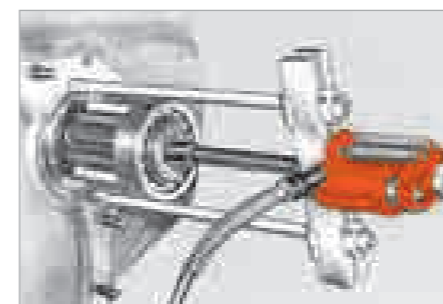

NOTE: L = leg length: 114; 241; 419; 572 and 762 mm subtract 124 mm from leg length to determine reach when using leg end caps.

Selection and capacity rating – Each Push-Puller's specified tonnage "capacity" is determined using its standard legs in tension. Using longer legs, or a setup in which the legs are in compression, will reduce the "capacity". Always select the largest "capacity" puller and the shortest legs that will fit the job.

Power Twin® cylinder – This unique center-hole cylinder powers each Push-Puller®. Puller screw runs right between the twin spring cylinder. A basic head allows you to change from a tapped hole to a plain hole by merely changing the head insert.

17½ ton capacity Push-Puller® -

No. PPH17 – Push-Puller® with RT172 center-hole Power Twin® cylinder, cylinder half coupler, P55 pump, 9767 1,8 m. hose, 9798 hose half coupler, 419 mm legs, 24827 leg ends, 1"-8 x 508 mm lg. adjusting screw and adjusting crank. Wt., 26,8 kg.

No. PPH17R – Same as above, but without P55 pump, 9767 1,8 m. hose and 9798 hose half coupler. Wt., 18,2 kg.

No. 1062 – Puller only. (Cylinder, pump, hose, coupler, screw and crank not included.) Wt., 9,1 kg.

USE WITH:

Bearing pulling attachments: **Nos. 1124 and 1130.**

Pulley pulling attachment: **No. 679.**

Internal pulling attachment: **No. 1154.**

Legs: **Nos. 1104, 1105, 1106, 1107 and 1108** - Pair of legs for 17½-ton "capacity" Push-Puller®.

ASSEMBLING THE TOOL TO APPLY PUSHING OR PULLING FORCE:

1. Determine if you want the tool's forcing screw to push or pull.
2. To exert pushing force, the forcing nut is installed beneath the cross block, as shown on left.
3. To cause the forcing screw to pull, the forcing nut is placed on top of the cross block.
4. The sliding plates must always be placed on the opposite side of the cross block from the forcing nut.

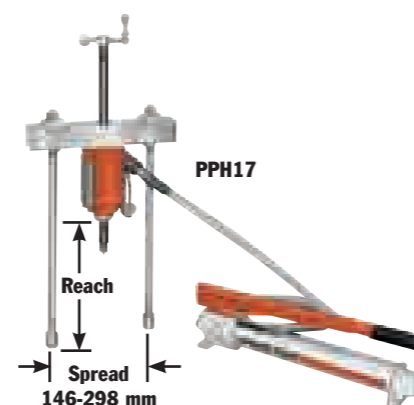
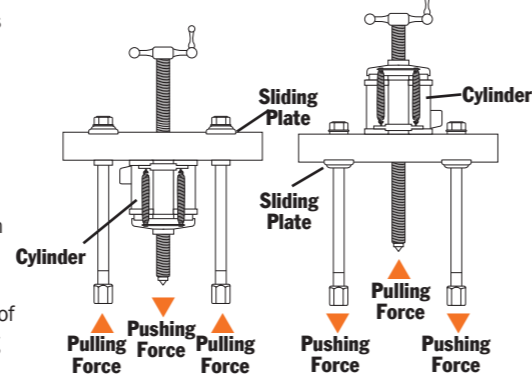

Leg Ends – Upper leg ends are threaded ¾"-16. Lower leg ends are threaded ¾"-18 x 25 mm lg.



Puller Sets HYDRAULIC

17½, 30 & 50 Ton

17½ ton hydraulic master puller sets

– Having this Power Team puller set at your fingertips will not only reduce your downtime, but also increase your profits.

No. IPS17 – 17½ ton capacity puller set. Includes hydraulics, pullers, wooden storage box and accessories listed below.

Wt., 86,7 kg.

No. IPS17B – Puller set with MB5 metal box. Wt., 96,7 kg.



Wooden storage box No. 3084350R9 is included with the sets listed on this page. 1.016L x 406 W x 406 mmD
Metal storage boxes also available (see page 209).



17½ ton hydraulic puller set - This set includes a 3-jaw puller and a Push-Puller®. Ideal for heavy duty applications; put this set to work wherever large gears, bearings, wheels, pulleys, etc. are found.

No. IPS17H – 17½ ton capacity hydraulic puller set. Includes hydraulics, pullers, wooden storage box and accessories listed below. Wt., 62,2 kg.

Contents	Hydraulics	Set Contents	Accessories
P55	Single-stage hyd. hand Pump assembly	1154	Bearing cup pulling attach
RT172	17½ ton cylinder with threaded insert	1122	Bearing pulling attachment
9798	Hose half coupler	1123	Bearing pulling attachment
9767E	Hydraulic hose – 1,8 m	1130	Bearing pulling attachment
9670	Tee adapter	Threaded Adapters	
9059E	Pressure gauge	679	V-belt pulley puling attachment
Pullers		8005	5/8" – 18 F. x 3/8" – 16 M. (2)
1062	17½ ton cap. Push-Puller® with 419 mm legs	8006	5/8" – 18 F. x 1/2" – 20 M. (2)
24814	Speed crank	8007	5/8" – 18 F. x 1/2" – 13 M. (2)
32118	Adjusting screw	8010	5/8" – 18 F. x 5/8" – 11 M. (2)
201923	Pushing adapter	8013	5/8" – 18 F. x 3/4" – 16 M. (2)
1105	572 mm legs (pr)	8015	5/8" – 18 F. x 3/4" – 10 M. (2)
1066	17½ ton 3-jaw hyd. puller	8017	5/8" – 18 F. x 7/8" – 14 M. (2)
1027	Combination 2/3-jaw puller	8018	5/8" – 18 F. x 7/8" – 9 M. (2)
41224	17½ ton 2-jaw puller head	8019	5/8" – 18 F. x 1" – 14 M. (2)
24832	Puller screw	8020	1" – 8 F. x 5/8" – 18 M. (1)
1037	Combination 2/3-jaw puller	8021	1" – 8 F. x 1" – 14 M. (1)
1041	Combination 2/3-jaw puller	8044	Female threaded adapter set
28228	Cylinder cap	8038	5/8" – 18 F. x 3/4" – 16 F. (2)
		8056	Set of 6 shaft protectors (8050-8055)
		8075	Set of 11 adaptors (8057-8067)

Contents	Hydraulics	Contents	Accessories
P55	Single-stage hydraulic hand pump assembly	1154	Bearing cup pulling attach.
RT172	17½ ton cylinder with threaded insert	1130	Bearing pulling attachment
9798	Hose half coupler	1105	572 mm legs (pr)
9767E	Hydraulic hose – 1,8 m	24814	Speed crank
9670	Tee adapter	28228	Screw cap
9059E	Pressure gauge	32118	Adjusting screw
Pullers		201454	Pushing adapter
1062	17½ ton cap. Push-Puller with 419 mm legs	41224	2-jaw head for 1066
1066	17½ ton 3-jaw hyd. puller	Threaded Adapters	
		8020	1" – 8 F. x 5/8" – 18 M. (1)
		8038	5/8" – 8 F. x 3/4" – 16 F. (1)

30 ton capacity puller set – Just what you need for those big jobs. Not only do you get a 30 ton hydraulic Push-Puller®, you also get a 2-jaw and 3-jaw hydraulic puller. Plus, many popular accessories and the hardware to tackle the big jobs right away.

No. IPS30H – 30 ton capacity hydraulic maintenance puller set. Includes hydraulics, pullers, wooden storage box and accessories listed below. Wt., 150 kg.

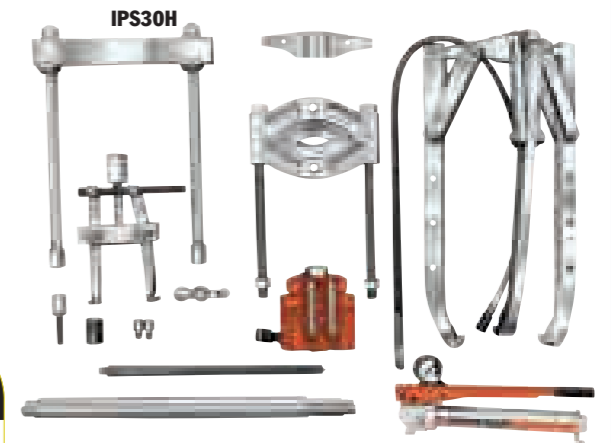

Contents	Hydraulics	Contents	Pullers
P55	Single-stage hydraulic hand pump assembly	1074	30 ton, 3-jaw hyd. puller
RT302	30 ton cylinder with threaded insert	41226	2-way head for 1074
9798	Hose half coupler	1070	30 ton cap. hydraulic Push-Puller® with 457 mm legs
9767E	Hydraulic hose – 1,8 m	1111	711 mm legs for 1070
9670	Tee adapter	27198	Speed crank
9059E	Pressure gauge	28229	Screw cap
Accessories		34510	Pushing adapter
8036	Female threaded adapters 1" – 14F. x 1" – 14F. (2)	34758	Adjusting screw
1166	Bearing cup pulling attach.		
1127	Bearing pulling attachment		



Note: Wooden storage box No. 3084380R9 is provided with the sets listed on this page. 1180L x 615H x 579D
Metal storage boxes also available (see page 209).

50 ton capacity puller set - For those really big jobs, this 50 ton puller set is what you need. Just think of the jobs you can do with a 50 ton hydraulic Push-Puller®, a 2-jaw and a 3-jaw puller, both with a 50 ton capacity. Of course, you also get many versatile accessories and attachments.

No. IPS50H – 50 ton capacity hydraulic maintenance puller set. Includes hydraulics, pullers, wooden storage box and accessories listed below. Wt., 261 kg.

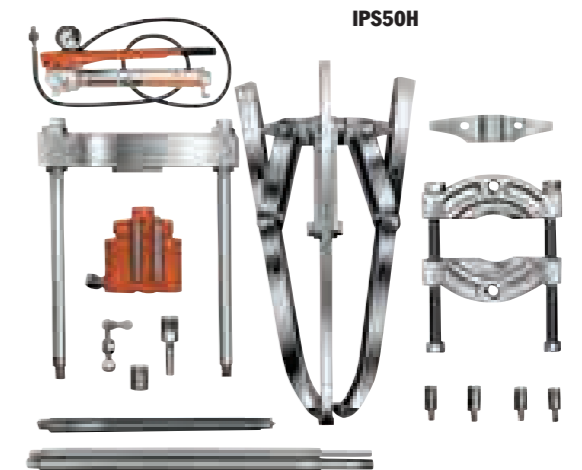

No.	Hydraulics	No.	Pullers
P55	Single-stage hydraulic hand pump assembly	1080	50 ton, 3-jaw hyd. puller
RT503	50 ton cylinder with threaded insert	50449	2-way head for 1080
9798	Hose half coupler	1076	50 ton cap. hydraulic Push-Puller® with 610 mm legs
9767E	Hydraulic hose – 1,8 m	1113	864 mm legs for 1076
9670	Tee adapter	29595	Speed crank
9059E	Pressure gauge	28230	Screw cap
Threaded Adapters		34755	Pushing adapter
8024	1¼" – 12F. x 1¾" – 12M. (2)	32698	Adjusting screw
8028	1½" – 5½" F. x 1" – 8M.	Accessories	
8029	1½" – 5½" F. x 1" – 14M.	1128	Bearing pulling attachment

CAUTION: All the items shown may not withstand the full tonnage specified. Example: When an accessory with a 1 ton capacity is used with a 7 ton puller, the setup can be used only at a force of 1 ton.

Puller Sets

HYDRAULIC

17½, 30 Ton & 50 Ton

PULLERS



Note: Wooden storage box No. 3084360R9 is provided with this set. 1.016 L x 432 H x 610 mm D Metal storage boxes also available (see page 209).

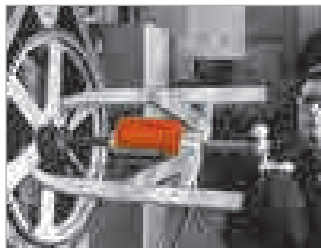

2-jaw puller reaches through spokes of gear to grip hub. Hand pump supplies hydraulic power.



Flexible coupler is removed from electric motor shaft with 2-jaw puller.

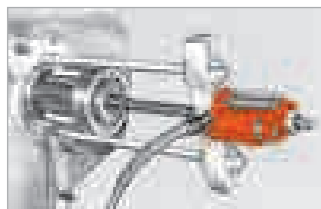

Typical setup for removing sprocket drive pinion shaft. Puller screw is attached to shaft by threaded adapter. Shaft is now ready to be pulled out hydraulically.

IPS3017



17½ and 30 ton capacity puller sets – These heavy-duty maintenance sets will more than pay for themselves, especially in saving you costly damage to parts. This set lets you tackle hundreds of applications where pushing and pulling are required.
No. IPS3017 – 17½ and 30 ton capacity manual and hydraulic puller set. Includes hydraulics, pullers, and accessories listed below. Wt., 244 kg.
No. IPS3017B – Puller set with MB8 metal box. Wt., 256 kg.

No.	Hydraulics	No.	Accessories
P55	Single-stage hyd. hand pump assembly	24832	Special puller forcing screw
RT172	17½ ton center-hole twin cylinder w/ threaded insert	8075	Step plate adapter set
RT302	30 ton center-hole twin cylinder w/ threaded insert	8076	Step plate adapter set
9798	Hose half coupler	8056	Shaft protector set
9767E	Hydraulic hose – 1,8 m	679	Pulley pulling attachment
9670	Tee adapter	680	Pulley pulling attachment
9059E	Pressure gauge	1154	Bearing cup pulling attach.
Pullers		1166	Bearing cup pulling attach.
1062	17½ ton cap. hydraulic Push-Puller® w/419 mm legs	1122	Bearing pulling attachment
1070	30 ton cap. hydraulic Push-Puller® w/457 mm legs	1123	Bearing pulling attachment
1066	17½ ton 3-jaw hyd. puller	1126	Bearing pulling attachment
1074	30 ton 3-jaw hyd. puller	1130	Bearing pulling attachment
41224	17½ ton 2-jaw puller head	Threaded Adapters	
41226	30 ton 2-jaw puller head	8005	5/8" – 18 F. x 3/8" – 16 M. (2)
1027	Combination 2/3-jaw puller	8006	5/8" – 18 F. x 1/2" – 20 M. (2)
1037	Combination 2/3-jaw puller	8007	5/8" – 18 F. x 1/2" – 13 M. (2)
1041	Combination 2/3-jaw puller	8010	5/8" – 18 F. x 5/8" – 11 M. (2)
43892	Long jaws (3) for 1037	8012	1" – 14 F. x 5/8" – 18 M. (2)
30902	Long jaws (3) for 1041	8013	5/8" – 18 F. x 3/4" – 16 M. (2)
1105	572 mm legs for 1062	8015	5/8" – 18 F. x 3/4" – 10 M. (2)
1111	711 mm legs for 1070	8017	5/8" – 18 F. x 7/8" – 14 M. (2)
24814	Speed crank	8018	5/8" – 18 F. x 7/8" – 9 M. (2)
27198	Speed crank	8019	5/8" – 18 F. x 1" – 14 M. (2)
28229	Screw cap	8020	1" – 8 F. x 5/8" – 18 M. (1)
28228	Cylinder cap	8021	1" – 8 F. x 1" – 14 M. (1)
32118	Adjusting screw	8025	1½" – 7 F. x 5/8" – 18 M. (2)
34758	Adjusting screw	8027	1½" – 7 F. x 1" – 14 M. (2)
34510	Pushing adapter	8036	1" – 14 F. x 1" – 14 F. (2)
201923	Pushing adapter	8038	5/8" – 18 F. x 3/4" – 16 F. (2)
		8044	Female threaded adapter set

CAUTION: All the items shown may not withstand the full tonnage specified. Example: When an accessory with a 1 ton capacity is used with a 7 ton puller, the setup can be used only at a force of 1 ton.

17½ and 50 ton capacity puller sets – If you're looking for a maintenance puller set that will handle a wide variety of applications, this is the one for you. The mechanical and hydraulic pullers and attachments are designed to handle most removing and installing jobs with a minimal amount of effort.

No. IPS5017 – 17½ and 50 ton capacity manual and hydraulic puller set. Includes hydraulics, pullers, wooden storage box and accessories listed below. Wt., 405 kg.

No. IPS5017B – Puller set with MB16 metal box. Wt., 415 kg.

IPSS017

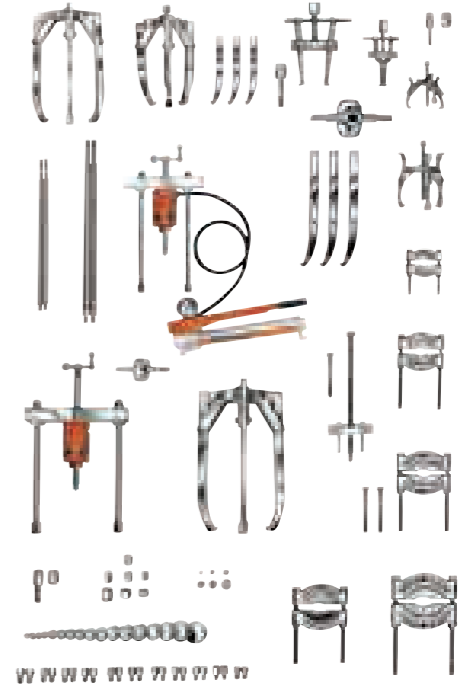

Note: Wooden storage box No. 3084360R9 is provided with this set. 1143 L x 572 H x 762 mm D Metal storage boxes also available (see page 209).

No.	Hydraulics	No.	Accessories
P55	Single-stage hyd. hand pump assembly	8075	Step plate adapter set
RT172	17½ ton center-hole twin cylinder w/ threaded insert	8076	Step plate adapter set
RT503	50 ton center-hole twin cylinder w/ threaded insert	8056	Shaft protector set
9798	Hose half coupler	1154	Bearing cup pulling attach.
9767E	Hydraulic hose – 1,8 m	1166	Bearing cup pulling attach.
9670	Tee adapter	1122	Bearing pulling attachment
9059E	Pressure gauge	1123	Bearing pulling attachment
Pullers		1126	Bearing pulling attachment
1062	17½ ton cap. hydraulic Push-Puller® w/419 mm legs	1130	Bearing pulling attachment
1076	50 ton cap. hydraulic Push-Puller® w/610 mm legs	34479	Reducing adapter for 1166
1066	17½ ton 3-jaw hyd. puller	10215	Hex nut; 3/4" – 16 (2)
1080	50 ton 3-jaw hyd. puller	24829	Short bolt
41224	17½ ton 2-jaw puller head	Threaded Adapters	
50449	50 ton 2-jaw puller head	8005	5/8" – 18 F. x 3/8" – 16 M. (2)
1027	Combination 2/3-jaw puller	8006	5/8" – 18 F. x 1/2" – 20 M. (2)
1037	Combination 2/3-jaw puller	8007	5/8" – 18 F. x 1/2" – 13 M. (2)
1041	Combination 2/3-jaw puller	8010	5/8" – 18 F. x 5/8" – 11 M. (2)
43892	Long jaws (3) for 1037	8013	5/8" – 18 F. x 3/4" – 16 M. (2)
30902	Long jaws (3) for 1041	8015	5/8" – 18 F. x 3/4" – 10 M. (2)
1105	572 mm legs for 1062	8019	5/8" – 18 F. x 1" – 14 M. (2)
1113	864 mm legs for 1076	8020	1" – 8 F. x 5/8" – 18 M. (1)
24814	Speed crank	8021	1" – 8 F. x 1" – 14 M. (1)
29595	Speed crank	8025	1½" – 7 F. x 5/8" – 18 M. (2)
28228	Screw cap	8027	1½" – 7 F. x 1" – 14 M. (2)
28230	Cylinder cap	8036	1" – 14 F. x 1" – 14 F. (2)
32118	Adjusting screw	8038	5/8" – 18 F. x 3/4" – 16 F. (2)
32698	Adjusting screw	8044	Female threaded adapter set
34755	Pushing adapter		
201923	Pushing adapter		
7392	Gear and pulley puller		
24833	Forcing screw for 7392		

CAUTION: All the items shown may not withstand the full tonnage specified. Example: When an accessory with a 1 ton capacity is used with a 7 ton puller, the setup can be used only at a force of 1 ton.



Combination of 50 ton capacity Push-Puller and cup pulling attachment simplifies the removal of a final drive axle seal.



Hydraulically powered Push-Puller removes drive wheel. Pulling attachment is used to provide gripping surface.



3-jaw puller provides grip while hydraulic hand pump provides power to push shaft from housing. Shaft protector is used on end of puller screw.

PULLERS

Puller Sets

HYDRAULIC

17½, 30 & 50 Ton

17½, 30 & 50 ton capacity puller set – Here's the ultimate in industrial puller sets! You'll find a puller for just about every job. Included in this "master set" are 17½, 30 and 50 ton hydraulics, along with an extensive assortment of pullers, attachments and adapters.

No. IPS5317 – 17½, 30 and 50 ton capacity manual and hydraulic puller set. Includes hydraulics, pullers, wooden storage box and accessories listed below. Wt., 572 kg.

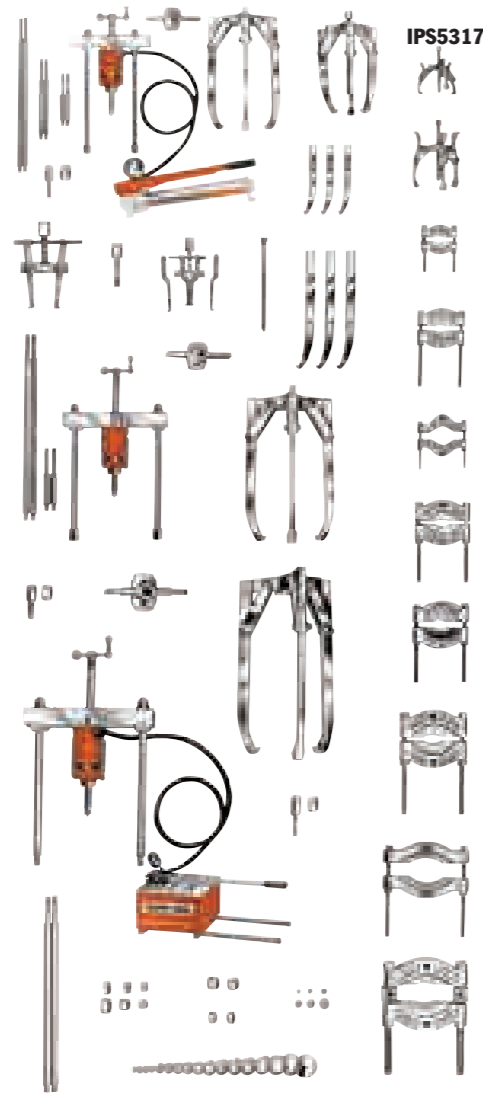

IPS5317



Note: Wooden storage box No. 3084400R9 is provided with this set. 1168 L x 571H x 571 mm D. Metal storage boxes also available (see page 207).

Contents	Hydraulics	Contents	Accessories
P55	Single-stage hyd. hand pump assembly	28230	Screw cap
P460	Two-stage hyd. hand pump w/ 3-way control valve	32118	Adjusting screw
RT172	17½ ton center-hole twin cylinder w/ threaded insert	32698	Adjusting screw
RT302	30 ton center-hole twin cylinder w/ threaded insert	34758	Adjusting screw
RT503	50 ton center-hole twin cylinder w/ threaded insert	34510	Pushing adapter
9798	Hose half coupler (2)	34755	Pushing adapter
9767E	Hydraulic hose – 1,8 m (2)	201923	Pushing adapter
9670	Tee adapter	8075	Step plate adapter set
9059E	Pressure gauge	8076	Step plate adapter set
	Pullers	8056	Shaft protector set
1062	17½ ton cap. hydraulic Push-Puller® w/419 mm legs	679	Pulley pulling attachment
1070	30 ton cap. hydraulic Push-Puller® w/457 mm legs	680	Pulley pulling attachment
1076	50 ton cap. hydraulic Push-Puller® w/610 mm legs	1154	Bearing cup pulling attach.
1066	17½ ton 3-jaw hyd. puller	1166	Bearing cup pulling attach.
1074	30 ton 3-jaw hyd. puller	1122	Bearing pulling attachment
1080	50 ton 3-jaw hyd. puller	1123	Bearing pulling attachment
41224	17½ ton 2-jaw puller head	1126	Bearing pulling attachment
41226	30 ton 2-jaw puller head	1127	Bearing pulling attachment
50449	50 ton 2-jaw puller head	1128	Bearing pulling attachment
1027	Combination 2/3-jaw puller	1128	Bearing pulling attachment
1037	Combination 2/3-jaw puller	1130	Bearing pulling attachment
1041	Combination 2/3-jaw puller	34479	Reducing adapter
43892	Long jaws (3) for 1037		Threaded Adapters
30902	Long jaws (3) for 1041	8005	5/8" – 18 F. x 3/8" – 16 M. (2)
32136	Long jaws (3) for 1154	8006	5/8" – 18 F. x 1/2" – 20 M. (2)
1105	572 mm legs for 1062	8007	5/8" – 18 F. x 1/2" – 13 M. (2)
1106	241 mm legs for 1062	8010	5/8" – 18 F. x 5/8" – 11 M. (2)
1107	114 mm legs for 1062	8012	1" – 14 F. x 5/8" – 18 M. (2)
1109	203 mm legs for 1070	8013	5/8" – 18 F. x 3/4" – 16 M. (2)
1111	711 mm legs for 1070	8015	5/8" – 18 F. x 3/4" – 10 M. (2)
1113	864 mm legs for 1070	8017	5/8" – 18 F. x 7/8" – 14 M. (2)
	Accessories	8018	5/8" – 18 F. x 7/8" – 9 M. (2)
24832	Special puller forcing screw	8019	5/8" – 18 F. x 1" – 14 M. (2)
24814	Speed crank	8020	1" – 8 F. x 5/8" – 18 M. (1)
27198	Speed crank	8021	1" – 8 F. x 1" – 14 M. (1)
29595	Speed crank	8023	1 1/4" – 12 F. x 1" – 14 M. (2)
28228	Screw cap	8024	1 1/4" – 12 F. x 1 1/4" – 12 M. (2)
28229	Screw cap	8025	1 1/4" – 7 F. x 5/8" – 18 M. (2)
		8027	1 1/4" – 7 F. x 1" – 14 M. (2)
		8028	1 5/8" – 5 1/2 F. x 1" – 8 M. (1)
		8029	1 5/8" – 5 1/2 F. x 1" – 14 M. (1)
		8036	1" – 14 F. x 1" – 14 F. (2)
		8038	5/8" – 18 F. x 3/4" – 16 F. (2)
		8044	Female threaded adapter set

CAUTION: All the items shown may not withstand the full tonnage specified. Example: When an accessory with a 1 ton capacity is used with a 7 ton puller, the setup can be used only at a force of 1 ton.

Bearing Pushers

8 Ton

These pushers are ideal for installing a wide variety of press-fit parts, including bushings, wheels, bearings, gears, and pulleys. Applications for the pushers will be found in motor repair shops, steel mills, mines, quarries, shipyards, utilities, maintenance shops, agricultural machinery repair, and the list goes on.

- Power Team, a leader in hydraulic tools for over 80 years, now adds patented, pushing systems to the world's most complete line of innovative equipment.
- Power Team pushers have been rigorously tested for top performance and reliability at maximum capacity.
- These pushing systems are covered by Power Team's exclusive Lifetime Marathon Warranty – assuring you of the highest quality and reliability.



3/4-16 thread 38,1 mm depth

BEARING PUSHER KITS

- Portable pushing kits include an external Grip-O-Matic puller, an internal puller, hydraulic cylinder, and a tri-section pulling attachment, all in one compact, lightweight unit complete with carrying case.

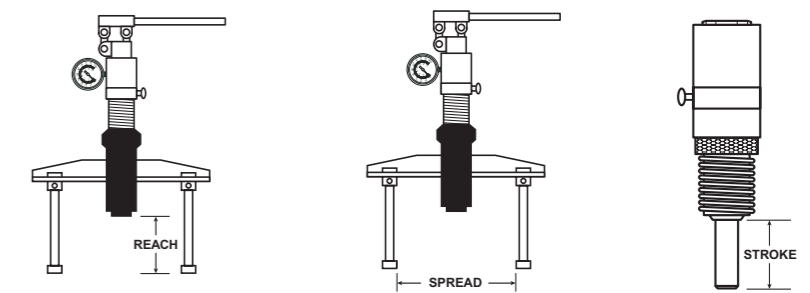

Order No.	Description	Cylinder Capacity	Reach (mm)	Spread (mm)	Stroke	Weight with Case (kg)
PHP8H	Manual-Hydraulic Pusher	8 tons	55-385	58-270	82	33.5
PHP8R	Remote Hydraulic Pusher	8 tons	55-385	58-270	82	33
PHP8H-1	Manual-Hydraulic Pusher/Puller Kit	8 tons	55-385	58-270	82	53
PHP8R-1	Remote Hydraulic Pusher/Puller Kit	8 tons	55-385	58-270	82	52

IMPORTANT SAFETY INFORMATION: Power Team recommends the use of protective blankets for all pushing operations. For ease of visual clarity, we have shown the pusher application photos without these safeguards.

Universal Puller

55 Ton & 100 TON
"Enforcer 55"
& Enforcer 100

PULLERS



Note: Four cylinder extensions (not pictured) are included. The included lifting eyes (not pictured) permit use of an overhead crane to raise entire assembly.

ENFORCER 55

- 1 Hydraulic lift system for easy, precise position of puller.
- 2 Unique dual pump arrangement: Low pressure pump positions, holds and opens jaws. The high pressure pump advances and retracts the pushing cylinder without releasing clamped jaws.
- 3 Hydraulically-actuated jaws. Cylinder moves in or out to provide a safe, secure grip on workpiece.
- 4 Puller can be assembled in 2 or 3 jaw configurations.
- 5 Choice of cylinder with a 159 mm or 337 mm stroke.
- 6 Self-centering: Center cylinder on work; puller jaws will automatically grip work evenly.
- 7 Super Grip-O-Matic® feature means the harder the pull, the tighter the puller jaws grip. No chains or cages required to keep puller jaws from slipping or springing off the part being pulled.
- 8 Guards at pinch points protect operator.
- 9 Cart's swivel casters give ease of mobility.
- 10 Large wheels make movement of cart easy.
- 11 Puller can be mounted on cart 90 degrees to right or left of puller cart centerline, permitting use in tight quarters, such as between machinery.

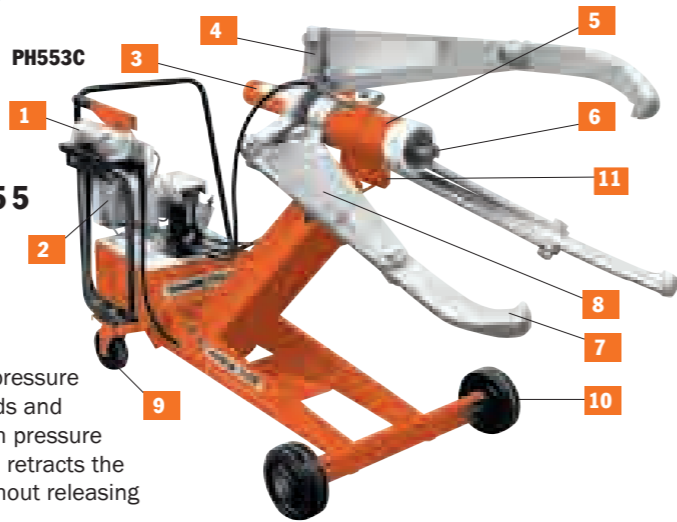

Conversion kit No. 251468 – Kit converts PH553C series to PH553CL series. Jaws are 305 mm longer. Kit contains three jaws and six straps with guards. Wt., 114 kg.

Pushing Adapters

Order No.	A (mm)	B (mm)	Qty.*
251002	69,9	69,9	1
350593	69,9	152,4	2
350594	69,9	76,2	1
350637	69,9	254	1

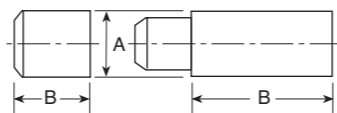

*Number of adapters supplied with each Enforcer.

(251002)

Order No.	Min. Spread (mm)	Min. Reach (mm)	Max. Spread (mm)	Max. Reach (mm)	Overall Length* (mm)	Cyl. Stroke (mm)	Power Source Requirements	Prod. Wt. (kg.)	Puller Jaw Tip Dimensions		
									A (mm)	B (mm)	C (mm)
PH553C-E220	101,6	559	1.219	356	2.286	159	230 V, 50 Hz, 15 Amp Cap.	339			
PH553C13-E220	101,6	381	1.219	178	2.286	337	230 V, 50 Hz, 15 Amp Cap.	352			
PH553CL-E220	63,5	829	1.149	737	2.591	159	230 V, 50 Hz, 15 Amp Cap.	366			
PH553CL13-E220	63,5	651	1.149	559	2.591	337	230 V, 50 Hz, 15 Amp Cap.	379			

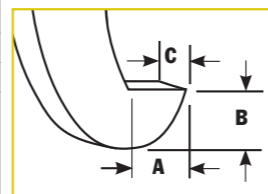

Note: See other pulling attachments on page 201. Also available in 110 Volt.
Note: Cart and Puller (cart width is 813 mm)

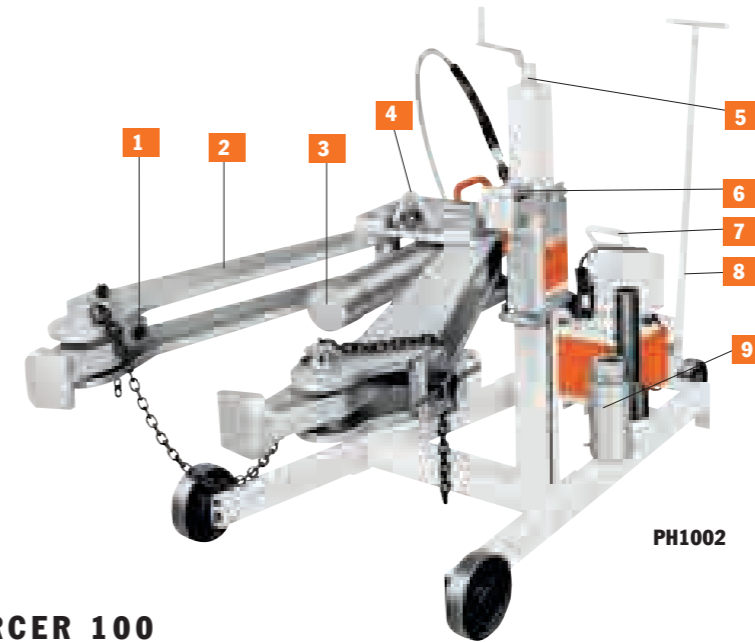

ENFORCER 100

- 1 Adjustable jaws mean they always pull on a flat surface. Retaining chain holds jaws in place during positioning.
- 2 Grip-O-Matic® feature means jaws grip progressively tighter as more pulling force is applied.
- 3 100 ton hydraulic cylinder is single-acting, spring return type with a maximum working pressure of 700 bar.
- 4 Lifting bracket allows puller to be lifted if the workpiece center is more than 914 mm off the floor.
- 5 Adjusting screw allows operator to move vertical position of the puller.
- 6 Spring loaded feature means Enforcer 100 will align itself on uneven pulls.
- 7 Hydraulic pump is a 2-stage, high pressure unit controlled by remote hand switch with 7,6 m cord.
- 8 Tow bar provides puller with plenty of mobility.
- 9 Pushing adapters have a diameter of 105 and 63,5 mm.

"Enforcer 100" universal puller –

No. PH1002 – 100 ton, 2-jaw universal hydraulic puller. Includes: 2-jaw Grip-O-Matic® puller, PE552S-E220 2-speed electric/hydraulic power unit, C10010C 100 ton hydraulic cylinder with 260 mm stroke and six adapters. Wt., 404 kg.

No. PH1002J – Same as PH1002-E220, but without hydraulic power unit. Wt., 375 kg.

PE552S-E220 – Pump only. 0,84 KW, 220 volt, 50Hz, single phase, draws 13 amps at full load. Also available in 115 volt, 50/60Hz.

Note: For 115 volt, 50/60Hz applications, order Part No. PH1002

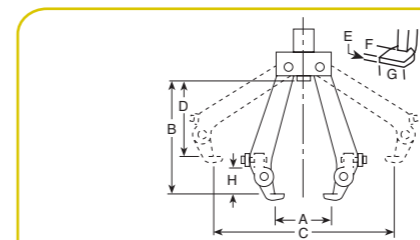

Order No.	Min. Spread (mm)	Min. Reach (mm)	Max. Spread (mm)	Max. Reach (mm)	Puller Jaw Tip (mm)	Cylinder Height (mm)	Vertical Stroke Adjust. (mm)	Overall Length (mm)	Max. Thickness Workpiece (mm)	Wheel Dia. (mm)	Power Source Requirements	
												A
PH1002-E220	381	1.067	1.219	864	25,4	57,1	127	305-914	2.388	305	260	220 V, 50 Hz, 13 Amp Cap.
PH1002J	381	1.067	1.219	864	25,4	57,1	127	305-914	2.388	305	260	–

Ram extensions

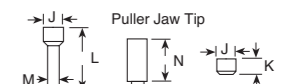

Order No.	Adapter Type	included w/puller	Amount				
			J (mm)	K (mm)	L (mm)	M (mm)	N (mm)
44745	Push	1	105	–	343	63,5	–
44766	Ext.	4	105	–	–	–	203
303045	Push	1	105	79,4	–	–	–

An ideal puller for steel mills, mines, oil fields, utility projects, paper mills, construction sites, railroads, airline shops, shipyards or anywhere else where large equipment and machinery pose tough maintenance challenges.

PULLERS

Roller Bearing PULLER/INSTALLER

(Railroad Edition)
100 Ton Pulling
Capacity

- Quickly remove or install tapered roller bearings.
- Designed with cooperation of major bearing manufacturers.
- It's a fast, simple, one-man operation with 100-tons of pulling force provided.
- Completely portable for easy, convenient positioning and out-of-the-way storage.
- The standard in most wheel shops.



Universal railroad axle journal roller bearing puller/installer – For years, the standard in most wheel shops. Power Team now has four models to choose from for greater flexibility. With both sling and jack models available and two pumps to choose from, you can tailor the unit to match your needs. With the proper equipment and know-how, removal and installation of axle journal roller bearings takes an absolute minimum of time and effort.

Each unit will service a full line of bearings with rotating end caps, from class B thru GG. No other method can match Power Team's simplicity. Removal is very easy. Simply remove the end caps, slip the pulling shoe between the bearings and the wheel, actuate the pump, and in seconds, 100 tons of pulling force removes the bearing. Installation is just as easy! Each unit is CSA certified (LR19814) and comes complete with a heavy-duty 100-ton hydraulic cylinder, 10,000 P.S.I. (700 bar) pump with remote control solenoid valve, hydraulic pressure gauge (No. 11543), a pulling shoe and installing tube.



Our roller bearing pullers are ideal for replacing tough, worn-out bearings on RR freight cars.



The photo above shows the Universal Puller in position on the roller bearing assembly, which is ready for removal.

Tooling order information - IMPORTANT...This tooling chart applies only to standard AAR configurations for freight care applications. In order to provide adapters needed to service housing-type locomotive and passenger car bearings, as well as metric bearings, Power Team must be provided with the following information: bearing manufacturer's name and general arrangement drawing number, size of bearing to be serviced, railroad name and location and part numbers of adapters already in your possession if you currently own a Puller/Installer.

Tool Description	Class and size of bearing assembly			
	120	130	140	150
Pulling Shoe Insert Adapter	No. 351830	No. 30512	No. 30521	No. 30520
Guide Tube & Cap Screw Assembly	No. 253341	No. 253342	No. 253343	No. 253344
Cap Screw**	No. 253339	No. 253394	No. 253339	No. 253395
Guide Tube Adapter	No. 21247	No. 21247	No. 21247	No. 21247
Installing Tube Adapter Ring	No. 253335	No. 253336	No. 253337	No. 253338

** Screws are supplied with the guide tube and should be ordered as replacements only.



Tool Description	Class and size of bearing assembly to be serviced									
	Class B 108 x 203 (No.)	Class C 127 x 229 (No.)	Class D 140 x 254 (No.)	Class E 152 x 279 (No.)	Class EE 140 Axle. (No.)	Class EE 152 Axle. (No.)	Class F 165 x 305 (No.)	Class G 178 x 305 (No.)	Class G 165 Axle. (No.)	Class GG 165 Axle. (No.)
Pulling Shoe	No. 420845 is included as part of basic machine – Do Not Order						420846	420846	420846	420846
Pulling Shoe	30522	30512	30521	30520	30520	30519	30519	–	–	–
Insert Adapter										
Guide Tube & Cap Screw Assembly	253313	253314	253317	253318	253316	253327	253320	253321	253319	253323
Cap Screw**	253156	253349	253308	253155	253307	253308	253310	253326	253309	253309
Guide TubeNo.	23934	21248	21248	21247	21247	21247	21247	21247	21247	21247
Adapter										
Installing Tube	No. 30416 is included as part of basic machine – Do Not Order						30417	30417	30417	30417
Installing Tube	21242	21258	21256-1	21255-1	21255-1	21257-1	21257-1	30586	30585	30585
Adapter Ring										

Note: Adapters listed above are for servicing the following roller bearing assemblies: Brenco "Crown-Taper", New Departure-Hyatt "Hy-Roll Taper", SKF "Expediter" and Timken "AP".

** Screws are supplied with the guide tube and should be ordered as replacements only.

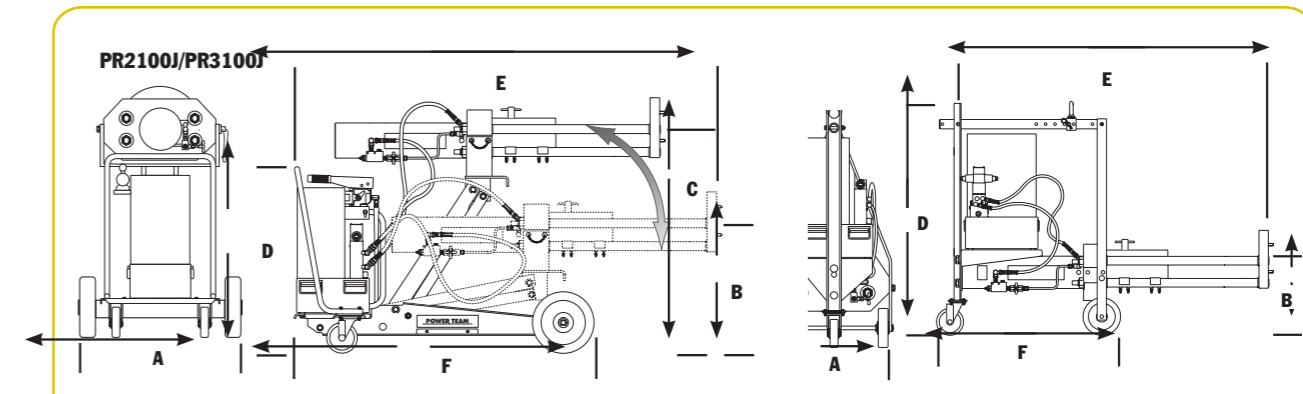

Order No.	Capacity						Speed						Weight (kg)
	Stroke (mm)	Pull (Tons)	Inst. (Tons)	Advance (mm/min.)	Pull (mm/min.)	Inst. (mm/min.)	A (mm)	B (mm)	C (mm)	D (mm)	E (mm)	F (mm)	
PR2100J	394	100	68	900	81	113	813	383	1.059	912	1.981	1.493	528
PR3100J	394	100	68	900	81	113	813	383	1.059	912	1.981	1.493	520
PR2100S	394	100	68	900	81	113	619	279	–	1.283	1.632	985	455
PR3100S	394	100	68	900	81	113	619	279	–	1.283	1.632	985	458

Drivers

Bearing, Bushing And Seal

PULLERS



27797 Master Set
(Board not included)



No. 27793
Starter Set



Patent No. 4,429,447
7180

Universal bearing cup installer

This installer adjusts to fit bearing cups from 92 to 165 mm O.D. Replaces over two dozen plates and drivers. Simply adjust the jaws to fit the cup I.D., lock the jaws, slip the new cup on and drive it home with a hammer. Will not damage new bearings.

No. 7180 - Univ. bearing cup installer. Wt., 4,5 kg.

Assemble your own "custom-made" driver tools

These sets include discs and hand-les for custom seal driver assembly to provide a pilot (to prevent cocking), a spacer (so force is applied on the proper area) and a driver (for even force dist.). Discs range from 12,7 thru 114,3 mm

diameters in 1,6 mm increments. Each set includes a handy plastic box with pre-cut tool tray.

No. 27793 - Starter Set. Contains handle and discs especially selected to provide the driver sizes most frequently needed. Maximum utility at a modest investment! Wt., 1,8 kg.

No. 27794 - Basic Set. Wide coverage, low investment! Includes 41 discs and two

handles. Size range: 12,7 thru 76,2 mm diameter. Wt., 10 kg.

No. 27795 - Big Job Set. Used for servicing large components. You get coverage of 77,8 thru 114,3 mm diameter with the 24 discs and handle provided. Wt., 20,4 kg.

No. 27797 - Master Set. For maximum coverage. Three handle sizes and all 65 discs listed in chart at left are included. Range: 12,7 thru 114,3 mm diameter. Wt., 30,9 kg.

No. 212377 - Tool organizer board. Will accommodate all components of 27793 Starter Set. Tools not included. Wt., 2,3 kg.

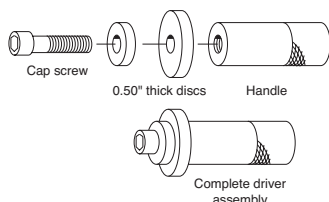

These sets have the proper-size driver for any seal, bearing or bushing installing job. Select the proper-size discs, attach to handle with cap screws and strike with hammer.

Order No.	DISCS Inch	MM	Order No.	DISCS Inch	MM	Order No.	DISCS Inch	MM
27492	9/16	14.3	27513†	1 7/8	47.6	27535	3 1/4	82.6
27493†	5/8	15.9	27514	1 15/16	49.2	27536	3 9/16	84.1
27494	1 1/16	17.5	27515	2	50.8	27537	3 7/8	85.7
27495†	3/4	19.0	27516	2 1/16	52.4	27538	3 7/16	87.3
27496	13/16	20.6	27517	2 1/8	54.0	27539	3 1/2	88.9
27497†	7/8	22.2	27518	2 3/16	55.6	27540	3 9/16	90.5
27498	15/16	23.8	27519	2 1/4	57.2	27541	3 5/8	92.1
27499†	1	25.4	27520	2 5/16	58.7	27542	3 11/16	93.7
27500	1 1/16	27.0	27521	2 3/8	60.3	27543	3 3/4	95.3
27501†	1 1/8	28.6	27522	2 7/16	61.9	27544	3 13/16	96.8
27502	1 3/16	30.2	27523	2 1/2	63.5	27545	3 7/8	98.4
27503†	1 1/4	31.8	27524	2 9/16	65.1	27546	3 15/16	100.0
27504	1 5/16	33.3	27525	2 5/8	66.7	27547	4	101.6
27505†	1 3/8	34.9	27526	2 11/16	68.3	27548	4 1/16	103.2
27506	1 7/16	36.5	27527	2 3/4	69.8	27549	4 1/8	104.8
27507†	1 1/2	38.1	27528	2 13/16	71.4	27550	4 3/16	106.4
27508	1 9/16	39.7	27529	2 7/8	73.0	27551	4 1/4	108.0
27509†	1 5/8	41.3	27530	2 15/16	74.6	27552	4 5/16	109.5
27510	1 11/16	42.9	27531	3	76.2	27553	4 3/8	111.1
27511†	1 3/4	44.4	27532	3 1/16	77.8	27554	4 7/16	112.7
			27533	3 1/8	79.4	27555	4 1/2	114.3

† = Items contained in 27793 starter set.

SET COMPONENTS	
Order No.	Description
10012†	1/4"-20 UNC X 22,2mm*
10020†	1/4"-20 UNC X 31,8 mm*
10854†	1/4"-20 UNC X 44,5 mm
10855†	1/4"-20 UNC X 70 mm*
12001†	1/4"-20 UNC X 2 1/4"*
27487†	Small Handle 127 X19mm Dia.
27488	Med. Handle 152 X 41mm Dia.
27489	Large Handle 152 X 41mm Dia.
27490	Extension Tube
7350†	Allen Wrench



SELECTING A PUNCH

The following information is provided as a convenient general reference guide for metal punching operations.

HOLE SIZE VS. MATERIAL THICKNESS

Punching holes in metal is the fast, economical way to get precise hole size, smoothness and minimum burr. Compressive strength of the punch steel determines that the thickness of the metal being punched must not exceed the diameter of the punch. This relationship varies with the type of material. For example: the minimum hole diameter will be 6,4 mm in 6,4 mm mild steel, 6,4 mm in 4,8 mm stainless steel, and 6,4 mm in 7,9 mm aluminum.

MAXIMUM RATED CAPACITY

All punching tools have their maximum capacity for safe, dependable operation over a long life span. The hydraulic punches listed in this catalog have a "rated capacity" based on their design strength. Before selecting a tool, use the following charts to determine the specific tonnage required to punch the size and shape holes through the type and gauge metal considered.

DETERMINING TONNAGES FOR ROUND HOLES

To determine tonnages for hot rolled mild steel (typically used in bar size angle iron, channels, tees and zeets) with a 3.500 bar shear strength, read directly from chart #1. Example: To punch a 9,5 mm diameter hole thru 9,5 mm thick mild steel, chart #1 shows 11.1 tons are required. For ASTM A-36 steel (typically used for structural size wide flange, H and I beams, tees and zeets) with a 4.200 bar shear strength, read direct from chart #2. Example: To punch a 6,4 mm round hole in 6,4 mm thick A-36 steel, chart #2 shows 5.9 tons of force is needed.

CHART #1		TONS OF PRESSURE REQUIRED TO PUNCH MILD STEEL												TONS OF PRESSURE
Material		Round Hole Diameter (mm)												
Thickness		3,2	4,8	6,4	7,9	9,5	11,1	12,7	14,3	15,9	17,5	19	20,6	
Gauge (mm)														
20	1/32	.4	.5	.7	.9	1.1	1.2	1.4	1.6	1.8	1.9	2.1	2.3	
18	3/64	.5	.7	.9	1.2	1.4	1.6	1.9	2.1	2.4	2.6	2.8	3.1	
16	1/16	.6	.9	.6	1.5	1.8	2.1	2.3	2.6	2.9	3.2	3.5	3.8	
14	5/64	.7	1.1	1.2	1.8	2.2	2.6	2.9	3.3	3.7	4.0	4.4	4.8	
12	7/64	1.0	1.5	1.5	2.6	3.1	3.6	4.1	4.6	5.1	5.7	6.2	6.7	
11	1/8	1.2	1.8	2.1	2.9	3.5	4.1	4.7	5.1	5.9	6.2	7.1	7.6	
10	9/64	1.3	2.0	2.4	3.3	4.0	4.6	5.3	5.9	6.6	7.3	7.9	8.6	
3/16"	3/16	--	2.8	2.6	4.6	5.5	6.4	7.4	8.3	9.2	10.1	11.0	12.0	
1/4"	1/4	--	--	3.7	6.1	7.4	8.6	9.8	11.1	12.3	13.5	14.7	16.0	
5/16"	5/16	--	--	4.9	7.8	9.2	10.7	12.3	13.9	15.4	17.0	18.5	20.0	
3/8"	3/8	--	--	--	--	11.1	12.8	14.8	16.5	18.5	20.2	22.1	23.8	
1/2"	1/2	--	--	--	--	--	--	19.7	22.0	24.6	26.9	29.5	31.8	

CHART #2		TONS OF PRESSURE REQUIRED TO PUNCH ASTM-A36 STRUCTURAL STEEL												
Material		Round Hole Diameter (mm)												
Thickness		3,2	4,8	6,4	7,9	9,5	11,1	12,7	14,3	15,9	17,5	19	20,6	
Gauge (mm)														
TONS OF PRESSURE	12	7/64	1.2	1.9	2.5	3.1	3.7	4.3	4.9	5.6	6.2	6.8	7.4	8.0
	11	1/8	1.4	2.1	2.8	3.5	4.2	4.9	5.7	6.4	7.1	7.8	8.5	9.2
	10	9/64	--	2.4	3.2	4.0	4.8	5.6	6.4	7.2	7.9	8.7	9.5	10.3
	3/16"	3/16	--	3.3	4.4	5.5	6.6	7.7	8.8	9.9	11.0	12.1	13.2	14.3
	1/4"	1/4	--	4.4	5.9	7.4	8.6	10.3	11.8	13.2	14.7	16.2	17.7	19.1
	5/16"	5/16	--	--	7.4	9.2	11.0	12.9	14.7	16.5	18.4	20.2	22.0	24.0
	3/8"	3/8	--	--	8.8	11.0	13.3	15.5	17.7	19.9	22.1	24.3	26.5	28.7
	1/2"	1/2	--	--	--	--	--	--	23.6	26.5	29.4	32.4	35.3	38.3

CHART #3 TONS OF PRESSURE REQUIRED TO SHEAR 25,4 MM LENGTH

Material Thickness	TONS OF PRESSURE		
	Mild Steel	Stainless Steel	Brass
4,8 mm	0,167	0,276	0,128
6,4 mm	0,246	0,374	0,177
7,9 mm	0,314	0,472	0,216
9,5 mm	0,373	0,560	0,246
11,1 mm	0,432	0,649	0,305
12,7 mm	0,491	0,737	0,344

DETERMINING TONNAGES FOR IRREGULAR SHAPED HOLES

When punching irregular shaped holes (square, obround, etc...) multiply the length of metal to be cut by the multiplier given for a 25,4 mm length of cut in chart #3. Example: The shear length (or total distance around a 12,7 mm square hole) is 50,8 mm. To punch such a hole in 6,4 mm thick mild

steel, multiply 50,8 mm x 6.25 (from chart #3) = 12.5 tons. For stainless steel this would be 50,8 mm x 9.5 = 19 tons.

DIE CLEARANCE

The relationship of the larger die hole size to the punch size is die clearance and is stated as a percentage of the thickness of the material being punched. The range of clearances varies from 10% for thin materials to 20% for thicker materials. For 19 mm material, the total die clearance is 3,8 mm. Clearance should always be specified when there is any reason for doubt.

Effects of die clearance are more noticeable in thicker materials (such as 12,7 mm) than in thinner materials (such as 4,8 mm). When ordering die sets, specify the type and thickness of material being punched (see chart #4).

CHART #4 CLEARANCE FOR MILD STEEL

Material Thickness	Approximate Decimal Thickness	Overall Clearance-Add to Punch Size	TONS OF PRESSURE
7 Gauge	4,55	0,5 mm	
3/16	4,76	0,58 mm	
1/4	6,35	0,94 mm	
5/16	7,94	1,2 mm	
3/8	9,5	1,45 mm	
1/2	12,7	1,90 mm	

NOTE: Most grades of half hard aluminum use the same clearance as shown above. In many cases, your own experience may dictate that you call for clearances different from the above, especially when punching other materials such as stainless steel. Special clearances may be ordered for that purpose.

DIE CLEARANCE HAS THE FOLLOWING EFFECTS:

Too much clearance	Too little clearance	Correct Clearance
1. Extra roll-in at top of the hole. 2. Too much burr at bottom of the hole.	1. More punching pressure needed. Can reduce tool life. 2. High stripping force causes part distortion and extra punch wear.	1. Straighter hole thru material. 2. Minimum distortion at top of hole. 3. Minimum burr at bottom of hole.

USE THE 200.300 OR 750 L/MIN TESTER TO SIMULATE ACTUAL OPERATING CONDITIONS OF THE SYSTEM UNDER TEST

Testing the pump: Operator runs engine at a specific rpm and adjusts tester's pressure compensating valve to simulate a work load. By comparing meter readings with manufacturer specs, proper operation of pump can be confirmed. If oil flow and pressure do not meet specs, the pump is faulty. Or, if test results and specifications agree, the operator will know that the problem is elsewhere in the system and that other tests must be performed. Regardless of the component being tested, hook-up and testing is accomplished in minutes. NOTE: These hydraulic testers should always be used with the owner's manual/manufacturers' specifications for the system under test.

BASE MOUNTING HOLES FOR "C" CYLINDERS

Cylinder Tonnage	No. Holes	Thread Size	Thread Depth (mm)	Bolt Circle Diameter (mm)
5	2†	¼-20	9.5	25.4
10		⅜-18	12.7	39.7
15		⅝-16		47.6
25		¾-13	19.1	58.7
55				95.3
* Optional 75	4	¾-10	25.4	114.3
* Optional 100		1-8		120.7

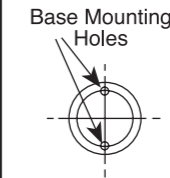

* Consult Factory (45° from coupler)
† 90° from coupler.

Cyl. Caps furnished with "C" Series Cylinders:
 5 ton cylinders **No. 201375**
 10 ton cylinders **No. 201362**
 15 ton cylinders **No. 201362**
 25 ton cylinders **No. 201412**
 55 ton cylinders **No. 36161**
 75 ton cylinders **No. 36161**
 100 ton cylinders **No. 36161**

PERFORMANCE

The table at right gives you an idea of what to expect when coupling RD series cylinders to a Power Team pump. Actual performance will vary according to job conditions.

Pump	Cylinder	Time to Extend Cylinder 25,4 mm	
		7 bar	700 bar
PE55	RD55	1.0 sec.	12.0 sec.
	RD100	1.8 sec.	22.5 sec.
	RD200	3.5 sec.	45.0 sec.
	RD400	7.2 sec.	85.0 sec.
PQ120 Series	RD200	3.4 sec.	20.6 sec.
	RD300	4.9 sec.	30.0 sec.
	RD400	6.4 sec.	39.0 sec.
PE400 Series	RD300	3.0 sec.	8.5 sec.
	RD400	3.9 sec.	11.1 sec.
	RD500	4.9 sec.	14.1 sec.

NOTE: Base mounting holes are standard on all RD cylinders. Orientation of base mounting holes to coupler. Orientation on RD300, RD400 & RD500 series is random.

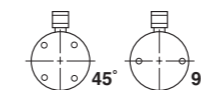

BASE MOUNTING HOLES FOR "RD" CYLINDERS

Tonnage	10	25	55	80	100	150	200	300	400	500
No. of Holes	2	4	4	4	4	4	4	4	4	6
Thread Size	⅜"-16	½"-13	⅝"-11	⅝"-11	¾"-10	1"-8	1 1/4"-7	1 1/4"-7	1 1/2"-12	1 3/8"-12
Depth (mm)	16	19	22	22	25	25	32	44	48	51
B.C. Dia.	51	70	89	114	140	152	165	159	184	203
Orientation	90°	45°	45°	45°	45°	45°	45°	Random	Random	Random

MOUNTING HOLES FOR "RLS" CYLINDERS

RLS50	8,6 mm C'bore x 6,4 mm deep, 5,6 mm thru hole	RLS200	15,5 mm C'bore x 10,4 mm deep, 10,4 mm thru hole	RLS500S	17,8 mm C'bore x 12,7 mm deep, 11,9 mm thru hole	RLS1000S	20,3 mm C'bore x 14,2 mm deep, 13,5 mm thru hole
RLS100	10,7 mm C'bore x 8,7 mm deep, 7,1 mm thru hole	RLS300	15,5 mm C'bore x 11,2 mm deep, 10,4 mm thru hole	RLS750S	20,3 mm C'bore x 14,2 mm deep, 13,5 mm thru hole	RLS1500S	20,6 mm C'bore x 14,2 mm deep, 13,5 mm thru hole

POST TENSION/STRESSING JACK DIMENSIONS

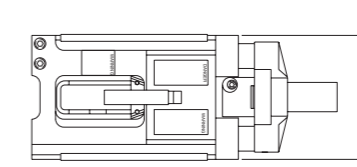
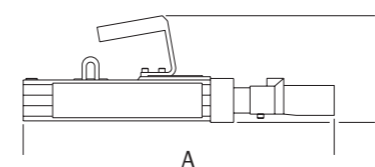

Order Number	A (mm)	B (mm)	C (mm)	Weight (kg)
SJ2010	533	229	165	25
SJ2010	559	259	178	34
SJ3010	559	259	178	34
SJ3010P	559	259	178	34
SJ2010DA	470	190	165	19
SJ3010DA	470	216	165	23

Conversion FORMULAS

	DECIMALS	MILLIMETERS
1/64	.015625	- 0.397
1/32	.03125	- 0.794
3/64	.046875	- 1.191
1/16	.0625	- 1.588
5/64	.078125	- 1.984
3/32	.09375	- 2.381
7/64	.109375	- 2.778
1/8	.1250	- 3.175
9/64	.140625	- 3.572
5/32	.15625	- 3.969
11/64	.171875	- 4.366
3/16	.1875	- 4.763
13/64	.203125	- 5.159
7/32	.21875	- 5.556
15/64	.234375	- 5.953
1/4	.2500	- 6.350

DECIMAL & MILLIMETER EQUIVALENTS

17/64	.265625	- 6.747	21/32	.65625	- 16.669
9/32	.28125	- 7.144	43/64	.671875	- 17.066
19/64	.296875	- 7.541	11/16	.6875	- 17.463
5/16	.3125	- 7.938		DECIMALS	MILLIMETERS
21/64	.328125	- 8.334	45/64	.703125	- 17.859
11/32	.34375	- 8.731	23/32	.71875	- 18.256
	DECIMALS	MILLIMETERS	47/64	.734375	- 18.653
23/64	.359375	- 9.128	3/4	.7500	- 19.050
3/8	.3750	- 9.525	49/64	.765625	- 19.447
25/64	.390625	- 9.922	25/32	.78125	- 19.844
13/32	.40625	- 10.319	51/64	.796875	- 20.241
27/64	.421875	- 10.716	13/16	.8125	- 20.638
7/16	.4375	- 11.113	53/64	.828125	- 21.034
29/64	.453125	- 11.509	27/32	.84375	- 21.431
15/32	.46875	- 11.906	55/64	.859375	- 21.828
31/64	.484375	- 12.303	7/8	.8750	- 22.225
1/2	.5000	- 12.700	57/64	.890625	- 22.622
33/64	.515625	- 13.097	29/32	.90625	- 23.019
17/32	.53125	- 13.494	59/64	.921875	- 23.416
35/64	.546875	- 13.891	15/16	.9375	- 23.813
9/16	.5625	- 14.288	61/64	.953125	- 24.209
37/64	.578125	- 14.684	31/32	.96875	- 24.606
19/32	.59375	- 15.081	63/64	.984375	- 25.003
39/64	.609375	- 15.478	1	1.000	- 25.400
5/8	.6250	- 15.875			
41/64	.640625	- 16.272			

1 mm = .03937"
.001" = .0254 mm

SI* CONVERSION FORMULAS

APPROXIMATE CONVERSION

MULTIPLY	BY	TO GET OR MULTIPLY	BY	TO GET
SI* UNIT	CONV FACTOR	NON-SI UNIT	CONV FACTOR	SI* UNIT
LENGTH				
millimeter (mm)	X 0.03937	= inch	X 25.4	= mm
(1 inch = 25.4 mm exactly)				
centimeter (cm) 10 mm	X 0.3937	= inch	X 2.54	= cm
meter (m) 1000 mm	X 3.28	= foot	X 0.305	= m
meter (m)	X 1.09	= yard	X 0.914	= m
kilometer (km) 1000 m	X 0.62	= mile	X 1.61	= km
AREA				
millimeter ² (mm ²)	X 0.00155	= inch ²	X 645	= mm ²
centimeter ² (cm ²)	X 0.155	= inch ²	X 6.45	= cm ²
meter ² (m ²)	X 10.8	= foot ²	X 0.0929	= m ²
meter ² (m ²)	X 1.2	= yard ²	X 0.836	= m ²
hectare (ha) 10,000 m ²	X 2.47	= acre	X 0.405	= ha
kilometer ² (km ²)	X 0.39	= mile ²	X 2.59	= km ²
VOLUME				
centimeter ³ (cm ³)	X 0.061	= inch ³	X 16.4	= cm ³
liter (l)	X 61	= inch ³	X 0.016	= l
milliliter (ml)	X 0.034	= oz-liq	X 29.6	= ml (1 ml = 1 cm ³)
liter (l) 1000 ml	X 1.06	= quart	X 0.946	= l
liter (l)	X 0.26	= gallon	X 3.79	= l
meter ³ (m ³) 1000 l	X 1.3	= yard ³	X 0.76	= m ³
MASS				
gram (g)	X 0.035	= ounce	X 28.3	= g
kilogram (kg) 1000 g	X 2.2	= pound	X 0.454	= kg
metric ton (t) 1000 kg	X 1.1	= ton (short)	X 0.907	= t

APPROXIMATE CONVERSION

MULTIPLY	BY	TO GET OR MULTIPLY	BY	TO GET
SI* UNIT	CONV FACTOR	NON-SI UNIT	CONV FACTOR	SI* UNIT
FORCE (N = kg • m/s²)				
newton (N)	X 0.225	= pound	X 4.45	= N
kilonewton (kN)	X 225	= pound	X 0.00445	= kN
TORQUE				
newton meter (N•m)	X 8.9	= lb. in.	X 0.113	= N•m
newton meter (N•m)	X 0.74	= lb. ft.	X 1.36	= N•m
PRESSURE (Pa = N/m²)				
kilopascal (kPa)	X 4.0	= in. H ₂ O	X 0.249	= kPa
kilopascal (kPa)	X 0.30	= in. Hg	X 3.38	= kPa
kilopascal (kPa)	X 0.145	= p.s.i.	X 6.89	= kPa
megapascal (MPa)	X 145	= p.s.i.	X 0.00689	= MPa
Bar	X 14.5	= p.s.i.	X .0689	= Bar
POWER (w = J/s)				
kilowatt (kw)	X 1.34	= hp	X 0.746	= kw
kilowatt (kw)	X 0.948	= Btu/s	X 1.055	= kw
watt (w)	X 0.74	= ft. lb/s	X 1.36	= w
TEMPERATURE				
°C = (°F - 32) ÷ 1.8		°F = (°C X 1.8) + 32		
FLOW				
cu. cm./min.	X .061	= cu. in./min.	X 16.4	= cu. cm./min.
liters/min.	X .2642	= GPM	X 3.785	= liters/min.

* System International (Modern Metric System)

Power Team's commitment to quality is evident in everything we do, from raw material receipt to how we support our customers years after they purchase our products. Power Team is registered to ISO 9001: 2000 international quality standard. ISO 9001: 2000 requires compliance with standards for management, administration, product development, manufacturing and continual improvement. Our Registration

verifies that Power Team has adopted and maintains documentation for processes ranging from suppliers to customers, inspection, handling, and training. ISO 9001 also requires periodic internal and external audits to ensure all aspects of work affecting quality control are monitored. This always has been, and will continue to be, our philosophy. That's our guarantee to you.



ASME B30.1

Power Team hydraulic cylinders fully comply with the criteria set forth in the American Society of Mechanical Engineers standard ASME B30.1:

1. Our cylinders are designed to have a minimum of a 2-to-1 safety factor on typical material yield strength;

Each cylinder is tested at 125 percent of rated pressure at full travel and is inspected to assure functionality and freedom from leaks.

ASME B40.1

Power Team heavy-duty pressure gauges are designed in accordance with the recommendations set forth in the American Society of Mechanical Engineers standard ASME B40.1, Grade B.

CE MARK

Power Team is committed to designing, manufacturing, and marketing products that meet or exceed the needs of the customers we serve. Power Team supplies a Letter of Incorporation or a Declaration of Conformity and CE Marking for products that conform with European community directives.

IJ100

Power Team hoses meet the criteria set forth in the Material Handling Institute's specification #IJ100 for hydraulic hose. Under the procedures outlined in this standard, hydraulic hose shall:

1. Have an average minimum life of 30,000 cycles at full rated capacity.
2. Have a minimum burst pressure of at least twice the rated operating pressure.



Where specified, Power Team electric power pump assemblies meet the design, assembly, and test requirements of the Canadian Standards Association. Note: If CSA certification is required, it must be requested at the time the pump is ordered.

NEMA

Where specified, Power Team electric power pump assemblies meet the design, assembly, and test requirements of NEMA 12, a National Electrical Manufacturers' Association standard relating to electrical components used to resist moisture and dust.

POWER TEAM PRODUCT DESIGN CRITERIA

All Power Team brand hydraulic components are designed and/or tested to be safe for use at maximum operating pressures of 700 bar unless otherwise specifically noted.

QUALITY ASSURANCE

All of our hydraulic cylinders are subjected to quality checks during production. All steel bar is certified and has material traceability to the mill. Before leaving the factory, all cylinders are pressure tested to 875 bar, except the RT series which are tested to 700 bar to insure on-the-job reliability. We have made every effort to include the latest specifications for our products in this catalog. Please call the Power Team factory for the most current product specifications. The Power Team Lifetime Marathon Warranty is described in more detail on pgs. 236 of this catalog.

Warranty



Warranty

“Power Team” is a registered trademark of the SPX Hydraulic Technologies division of SPX FLOW Inc. All Power Team products and parts, with the exceptions noted below, are warranted against defects in materials and workmanship for the life of the product or part. (The life of the product or part is defined as that point in time when it no longer safely or properly functions due to normal wear). Inflatable jacks, chains, batteries, electric motors, gas engines, knives and cutter blades which are sold with Power Team products are not covered by this warranty and instead are warranted as follows:

- Inflatable jacks and electronics are warranted against defects in materials and workmanship for a period of one year from date of purchase.
- Consumable parts or accessories, including without limitation, chains, batteries, knives and cutter blades are warranted against defects in materials and workmanship for a period of one year from date of purchase.
- All electric motors and gas engines are separately warranted by their respective manufacturer under the terms and conditions stated in their separate warranty.

The foregoing warranties do not cover ordinary wear and tear or any product or part that has been worn out, abused, heated, ground or otherwise altered, used for a purpose other than that for which it was intended or used in a manner inconsistent with any instructions regarding its use.

To qualify for warranty consideration, return the Power Team product, freight prepaid, to a Power Team authorized repair center or to the SPX FLOW factory. If any product or part manufactured by SPX FLOW found to be defective by SPX FLOW, in its sole judgment, SPX FLOW will, at its option, either repair or replace such defective product or part and return it via best ground transportation, freight prepaid. THIS REMEDY SHALL BE THE EXCLUSIVE REMEDY AVAILABLE FOR ANY DEFECTS IN THE PRODUCTS OR PARTS MANUFACTURED AND SOLD BY SPX FLOW OR FOR DAMAGES RESULTING FROM ANY OTHER CAUSE WHATSOEVER, INCLUDING WITHOUT LIMITATION, SPX FLOW's NEGLIGENCE. SPX FLOW SHALL NOT, IN ANY EVENT, BE LIABLE TO ANY BUYER FOR CONSEQUENTIAL OR INCIDENTAL DAMAGES OF ANY KIND, WHETHER FOR DEFECTIVE OR NON-CONFORMING GOODS, NEGLIGENCE, ON THE BASIS OF STRICT LIABILITY OR FOR ANY OTHER REASON.

SPX FLOW's Warranty is expressly limited to persons who purchase Power Team products or parts for the resale or for use in the ordinary course of the buyer's business.

THIS WARRANTY IS EXCLUSIVE, AND SPX FLOW MAKES NO OTHER WARRANTY OF ANY KIND WHATSOEVER, EXPRESSED OR IMPLIED, WITH RESPECT TO THE PRODUCTS MANUFACTURED AND SOLD BY IT, WHETHER AS TO MERCHANTABILITY, FITNESS FOR A PARTICULAR PURPOSE, OR ANY OTHER MATTER. No agent, employee, or representative of SPX FLOW has any authority to bind SPX FLOW to any affirmation, representation, or warranty concerning Power Team products or parts, except as stated herein.

The purpose of this exclusive remedy shall be to provide the buyer with repair or replacement of products or parts manufactured by SPX FLOW found to be defective in materials or workmanship or negligently manufactured. This exclusive remedy shall not be deemed to have failed of its essential purpose so long as SPX FLOW is willing and able to replace said defective products or parts in the prescribed manner.

> Power Team



HYDRAULIC PUMPS | CYLINDERS | JACKS | PULLERS | TOOLS

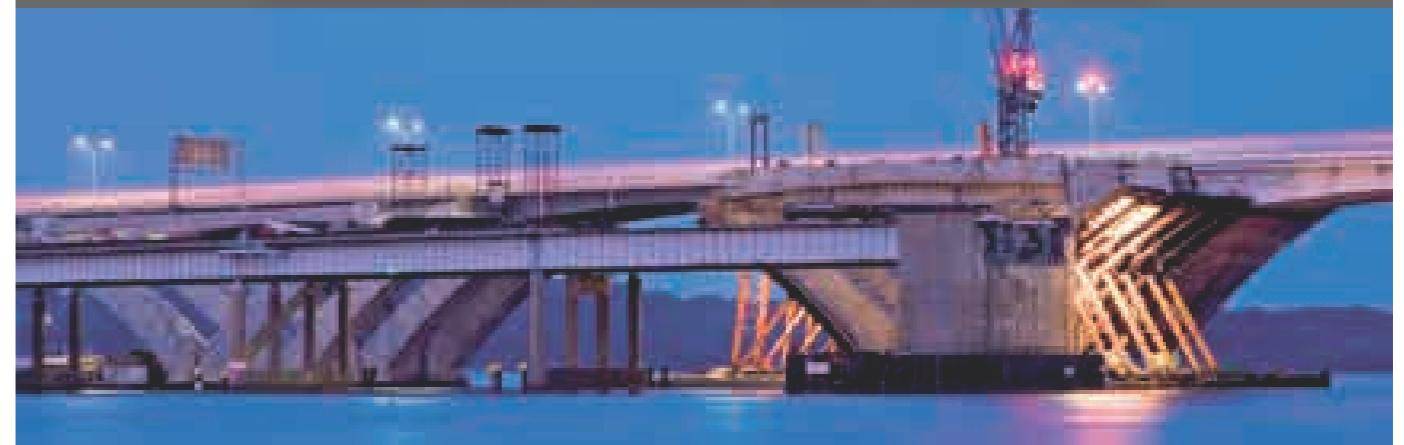

powerteam.com

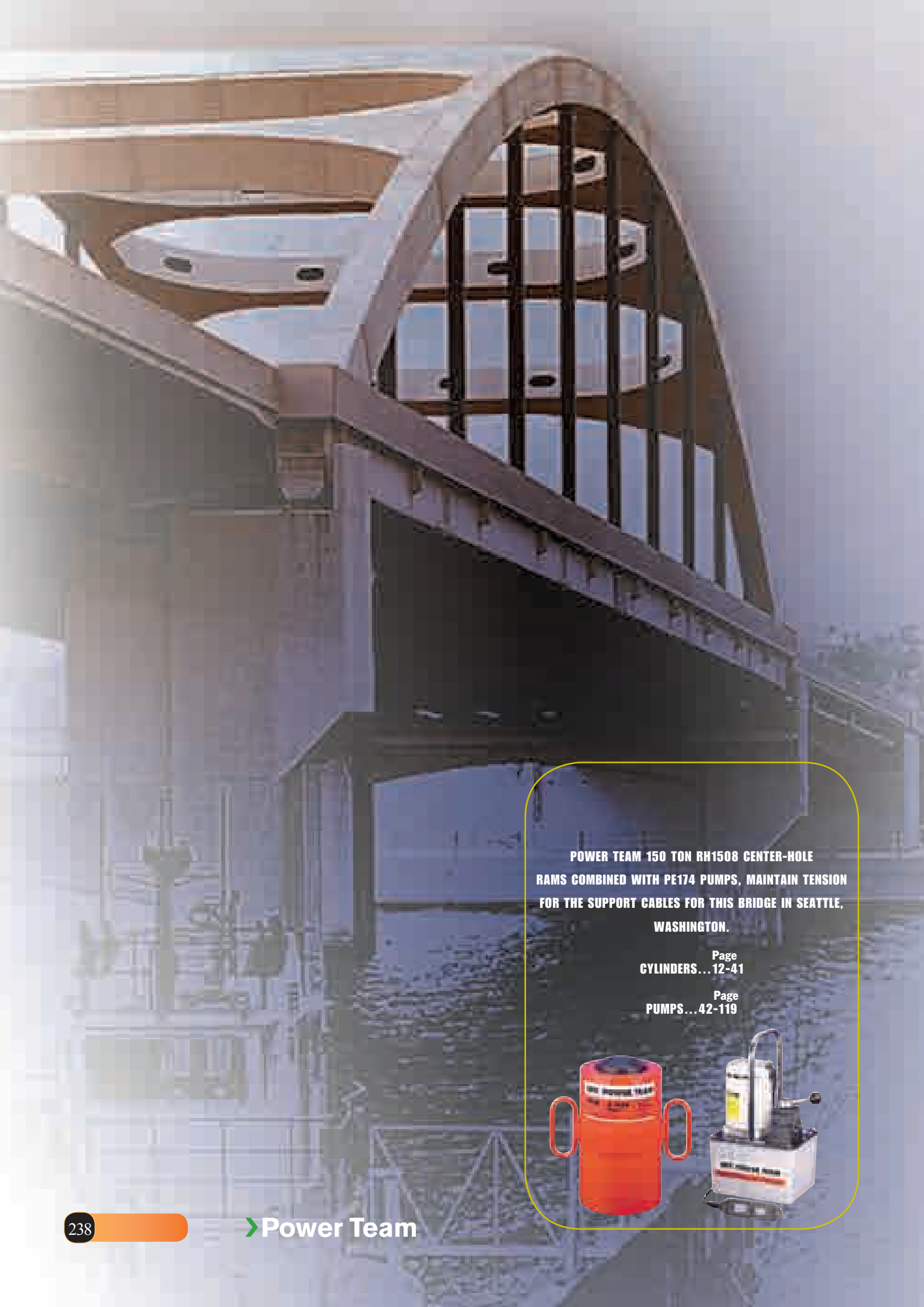

**POWER TEAM 150 TON RH1508 CENTER-HOLE
RAMS COMBINED WITH PE174 PUMPS, MAINTAIN TENSION
FOR THE SUPPORT CABLES FOR THIS BRIDGE IN SEATTLE,
WASHINGTON.**

**Page
CYLINDERS...12-41**

**Page
PUMPS...42-119**



Power Team University



Proper training is needed to operate and maintain hydraulic equipment with safety and efficiency. Power Team offers a range of classes to help you safely operate and maintain your tools.

Safety Training

Workplace safety should be a high priority to assure high-pressure hydraulic tools are used in accordance with recommended safety procedures. Power Team Safety Training Seminars demonstrate the proper methods for operating high-pressure hydraulic tools to avoid equipment damage and lost time accidents. Safety seminars can be conducted at a customer facility, job site or Power Team headquarters.

Maintenance & Repair Training

Maintaining Power Team products in good operating condition enhances operating efficiency and extends service life. This seminar explains the proper methods for keeping Power Team products operating at peak levels of performance and reliability. Topics include understanding hydraulic circuits, product maintenance, troubleshooting, and field repairs. Three and five day seminars are structured to meet your product knowledge requirements.

Class schedules are posted on powerteam.com. Contact your district sales manager for more details or call **+31 45 5678877**.

SPXFLOW

**Cylinders
P6-P41**



**Pumps
P42-P119**



**Accessories
P120-P133**



**Shop Equipment
P134-P147**



**Jacks
P148-P163**



**Hydraulic Tools
P164-P189**



**Pullers
P190-P230**



**Resources
P231-P234**



CUSTOMER SERVICE CENTERS

**North America Customer
Service Center**

Rockford, Illinois USA

5885 11th Street
Rockford, IL 61109
USA
info@powerteam.com

European Headquarters

Albert Thijsstraat 12
6471 WX Eygelshoven
The Netherlands
Tel: +31 45 567 8877
Fax: +31 45 567 8878
infoeurope@powerteam.com

Asia Pacific Headquarters

26 Soon Lee Road
Singapore 628086
Singapore
Tel: +65 6265 3343
Fax: +65 6265 6646
infoasia@powerteam.com

Customer Service/Order Entry

Tel: +1 800 541 1418
Fax: +1 800 288 7031

Technical Services

Tel: +1 800 477 8326
Fax: +1 800 765 8326

Shanghai, China

No. 1568 Hua Shan Road
7F Treasury Building
Shanghai 200052, China
Tel: +86 21 2208 5888
Fax: +86 21 2208 5682
infochina@powerteam.com

ENGINEERING, MANUFACTURING AND SUPPORT CENTER

World Headquarters

5885 11th Street
Rockford, IL 61109, USA
Tel: +1 815 874 5556
Fax: +1 800 288 7031
info@powerteam.com

Your Power Team Distributor

Blank area for distributor information.